

CUSCINETTI MAGGIORATI PER LAVORAZIONI PESANTI

Reinforced bearings for
heavy machining

Vergroesserte Lager fuer
schwerere Bearbeitungen

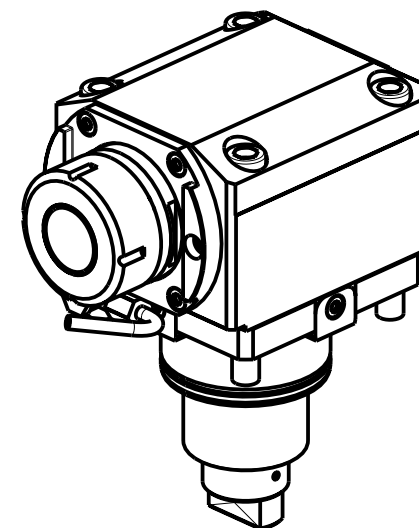
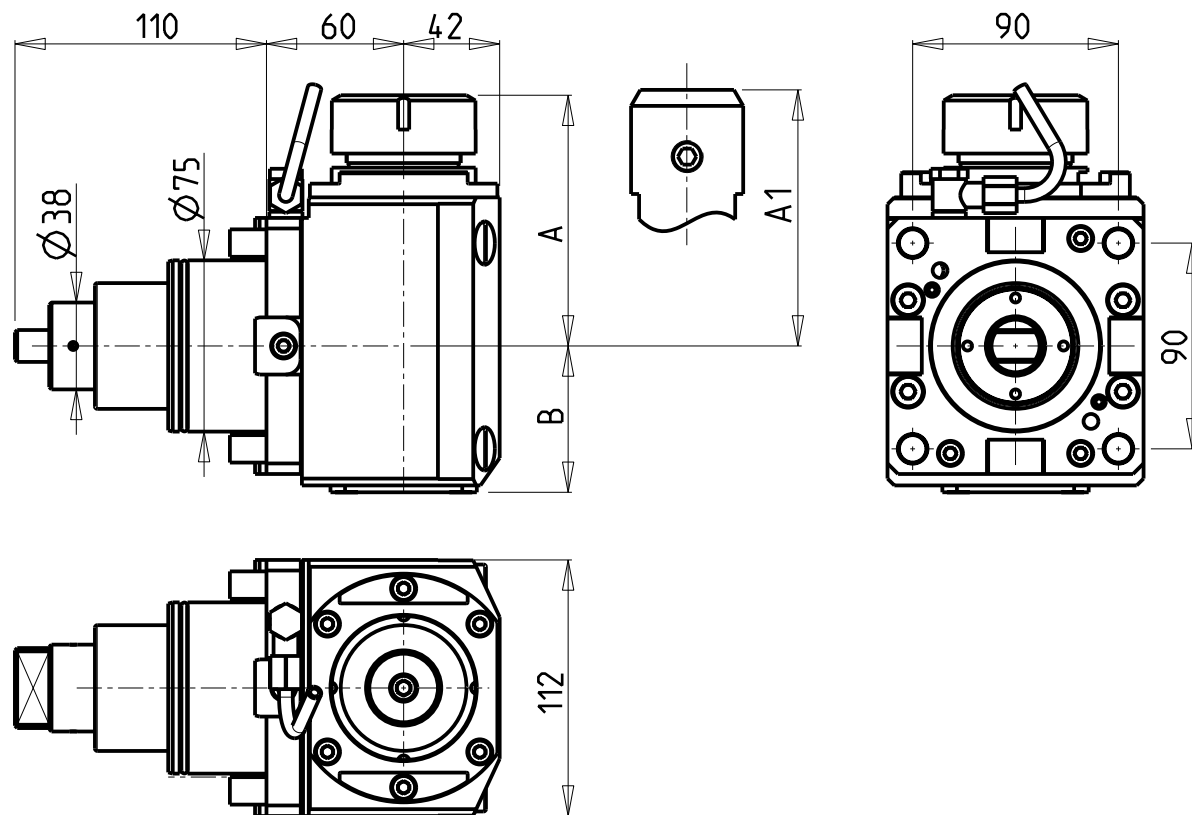

- Chiave inclusa
- Key included
- Schluessel inbegriffen

Cod. MT	Mandrino Spindle Spindel	I	RPM	Coppia Max Max Torque Max Drehmoment	Lubrificazione int. Coolant through Innenkuehlung	Lubrificazione est. Ext. coolant Aussenkuehlung	A	A1	B	CHIAVI NON INCLUSE Keys not included Schluessel nicht einbegriffen	
										CHSTER40	OKU0430007
DW 00680140	ER40	1:1	6000	140Nm	-	X	109.7	-	64	CHSTER40	OKU0430007
DW 00680240	ER40	1:1	6000	140Nm	P=70bar	X	109.7	-	76.5	CHSTER40	OKU0430007
DW 00680725	WELDON 25	1:1	6000	140Nm	-	X	-	109.5	64	-	-
DW 00680825	WELDON 25	1:1	6000	140Nm	P=70bar	X	-	109.5	76.5	-	-

DOOSAN BMT 75

MOD: PUMA 400 - PUMA 480M/LM/XLM - PUMA 4100M - PUMA 5100M - V550M - V8300M

MODULO MOTORIZZATO ASSIALE MAGGIORATO H=60mm

Axial reinforced driven tool H=60mm

Axial angetriebenes Werkzeug vergroessert H=60mm

Subject to change without notice.

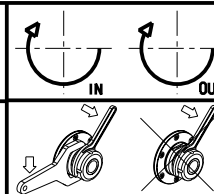

M.T. srl

Via Casino Albini 480
Tel. 0541/956034-957884
Fax 0541/956341
47842 S. GIOVANNI IN M. (RN)
e-mail: mtma@mtmarchetti.com
http://www.mtmarchetti.com

PRODUZIONE MODULI ROTANTI



PAGINA DW0170-4-10