

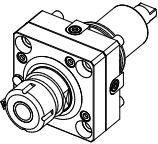
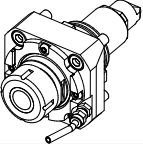
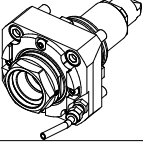
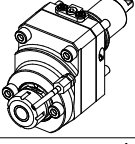
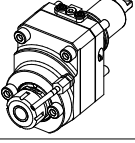
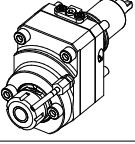
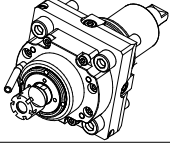
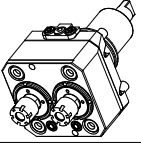
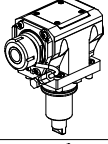
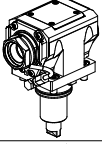
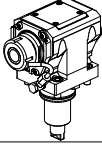
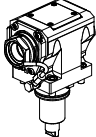
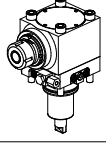
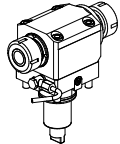
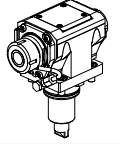
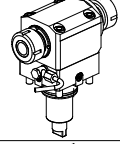
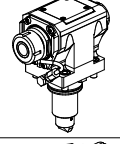
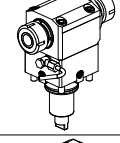
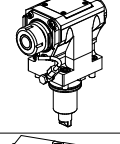
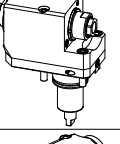
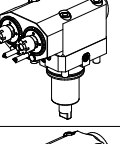
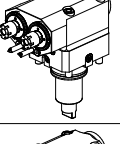
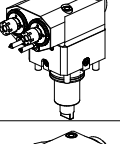
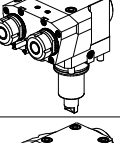
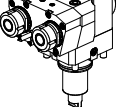
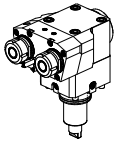
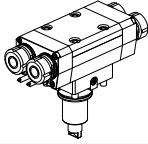
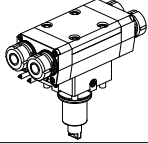
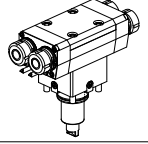
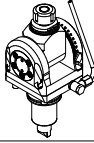

		PAGINA Page Seite
MODULO MOTORIZZATO RADIALE Radial driven tool Radial angetriebenes Werkzeug		DW 0010.2.00
MODULO MOTORIZZATO RADIALE Radial driven tool Radial angetriebenes Werkzeug		DW 0010.2.01
MODULO MOTORIZZATO RADIALE MTSK Radial MTSK driven tool Radial MTSK angetriebenes Werkzeug		DW 0010.2.01.K
MODULO MOTORIZZATO RADIALE DISASSATO IN Z 36mm Radial driven tool re-directed in Z by 36mm Radial angetriebenes Werkzeug achsversetzt in Z um 36mm		DW 0030.2.10
MODULO MOTORIZZATO RADIALE RIDOTTO I=2:1 DISASSATO IN Z 36mm Radial geared-down I=2:1 driven tool re-directed in Z by 36mm Radial angetriebenes Werkzeug untersetzt I=2:1 achsversetzt in Z um 36mm		DW 0030.2.20
MODULO MOTORIZZ. RADIALE MOLTIPLICATO I=1:2 DISASSATO IN Z 36mm Radial geared-up I=1:2 driven tool re-directed in Z by 36mm Radial angetriebenes Werkzeug uebersetzt I=1:2 achsversetzt in Z um 36mm		DW 0030.2.30
MODULO MOTORIZ. RADIALE MOLTIPLICATO I=1:5,625 Radial geared-up I=1:5,625 driven tool Radial angetriebenes Werkzeug uebersetzt I=1:5,625		DW 0060.2.00
MODULO MOTORIZZATO RADIALE 2 USCITE IN Y Radial single side twin head driven tool in Y Radial angetriebenes Werkzeug 2 Ausgaenge in Y		DW 0080.2.00
MODULO MOTORIZZATO ASSIALE H=60mm Axial driven tool H=60mm Axial angetriebenes Werkzeug H=60mm		DW 0150.2.11
MODULO MOTORIZZATO ASSIALE MTSK H=60mm Axial MTSK driven tool H=60mm Axial MTSK angetriebenes Werkzeug H=60mm		DW 0150.2.11.K
MODULO MOTORIZZATO ASSIALE H=70mm Axial driven tool H=70mm Axial angetriebenes Werkzeug H=70mm		DW 0150.2.21
MODULO MOTORIZZATO ASSIALE MTSK H=70mm Axial MTSK driven tool H=70mm Axial MTSK angetriebenes Werkzeug H=70mm		DW 0150.2.21.K

		PAGINA Page Seite
MODULO MOTORIZZATO ASSIALE H=85mm Axial driven tool H=85mm Axial angetriebenes Werkzeug H=85mm		DW 0150.2.31
MODULO MOTORIZZATO ASSIALE MTSK H=85mm Axial MTSK driven tool H=85mm Axial MTSK angetriebenes Werkzeug H=85mm		DW 0150.2.31.K
MODULO MOTORIZZATO ASSIALE ARRETRATO Axial rear-set driven tool Axial angetriebenes Werkzeug zurueckversetzt		DW 0180.2.10
MODULO MOTORIZZATO ASSIALE MOLTIPLICATO I=1:2 H=60mm Axial geared-up I=1:2 driven tool H=60mm Axial angetriebenes Werkzeug uebersetzt I=1:2 H=60mm		DW 0200.2.10
MODULO MOTORIZZATO ASSIALE MOLTIPLICATO I=1:2 H=70mm Axial geared-up I=1:2 driven tool H=70mm Axial angetriebenes Werkzeug uebersetzt I=1:2 H=70mm		DW 0200.2.20
MODULO MOTORIZZATO ASSIALE MOLTIPLICATO I=1:2 H=85mm Axial geared-up I=1:2 driven tool H=85mm Axial angetriebenes Werkzeug uebersetzt I=1:2 H=85mm		DW 0200.2.30
MODULO MOTORIZZATO ASSIALE MOLTIPLICATO I=1:5,625 H=60mm Axial geared-up I=1:5,625 driven tool H=60mm Axial angetriebenes Werkzeug uebersetzt I=1:5,625 H=60mm		DW 0210.2.10
MODULO MOTORIZZATO ASSIALE MOLTIPLICATO I=1:5,625 H=70mm Axial geared-up I=1:5,625 driven tool H=70mm Axial angetriebenes Werkzeug uebersetzt I=1:5,625 H=70mm		DW 0210.2.20
MODULO MOTORIZZATO ASSIALE MOLTIPLICATO I=1:5,625 H=85mm Axial geared-up I=1:5,625 driven tool H=85mm Axial angetriebenes Werkzeug uebersetzt I=1:5,625 H=85mm		DW 0210.2.30
MODULO MOTORIZZATO ASSIALE PER POLIGONATURA INTERNA H=60mm Axial driven tool for internal polygon-making H=60mm Axial angetriebenes Werkzeug fuer interne Facettierung H=60mm		DW 0230.2.10
MODULO MOTORIZZATO ASSIALE PER POLIGONATURA INTERNA H=70mm Axial driven tool for internal polygon-making H=70mm Axial angetriebenes Werkzeug fuer interne Facettierung H=70mm		DW 0230.2.20
MODULO MOTORIZZATO ASSIALE PER POLIGONATURA INTERNA H=85mm Axial driven tool for internal polygon-making H=85mm Axial angetriebenes Werkzeug fuer interne Facettierung H=85mm		DW 0230.2.30

		PAGINA Page Seite
MODULO MOTORIZZATO ASSIALE BISPORGENTE H=60mm Axial opposite face twin driven tool H=60mm Axial angetriebenes Werkzeug halb vorspringend H=60mm		DW 0240.2.10
MODULO MOTORIZZATO ASSIALE BISPORGENTE H=60mm Axial opposite face twin driven tool H=60mm Axial angetriebenes Werkzeug halb vorspringend H=60mm		DW 0240.2.11
MODULO MOTORIZZATO ASSIALE BISPORGENTE H=70mm Axial opposite face twin driven tool H=70mm Axial angetriebenes Werkzeug halb vorspringend H=70mm		DW 0240.2.20
MODULO MOTORIZZATO ASSIALE BISPORGENTE H=70mm Axial opposite face twin driven tool H=70mm Axial angetriebenes Werkzeug halb vorspringend H=70mm		DW 0240.2.21
MODULO MOTORIZZATO ASSIALE BISPORGENTE H=85mm Axial opposite face twin driven tool H=85mm Axial angetriebenes Werkzeug halb vorspringend H=85mm		DW 0240.2.30
MODULO MOTORIZZATO ASSIALE BISPORGENTE H=85mm Axial opposite face twin driven tool H=85mm Axial angetriebenes Werkzeug halb vorspringend H=85mm		DW 0240.2.31
MODULO MOTORIZZATO ASSIALE ARRETRATO BISPORGENTE Axial opposite face rear-set driven tool Axial angetriebenes Werkzeug zurueckversetzt halb vorspringend		DW 0243.2.10
MODULO MOTORIZZATO ASSIALE 2 USCITE IN Y H=60mm Axial single side twin head driven tool in Y H=60mm Axial angetriebenes Werkzeug 2 Ausgaenge in Y H=60mm		DW 0260.2.10
MODULO MOTORIZZATO ASSIALE 2 USCITE IN Y H=70mm Axial single side twin head driven tool in Y H=70mm Axial angetriebenes Werkzeug 2 Ausgaenge in Y H=70mm		DW 0260.2.20
MODULO MOTORIZZATO ASSIALE 2 USCITE IN Y H=85mm Axial single side twin head driven tool in Y H=85mm Axial angetriebenes Werkzeug 2 Ausgaenge in Y H=85mm		DW 0260.2.30
MODULO MOTORIZZ. ASSIALE 2 USCITE IN Y MOLTIPLICATO I=1:2 H=60mm Axial geared-up I=1:2 single side twin head driven tool in Y H=60mm Axial angetriebenes Werkzeug 2 Ausgaenge in Y uebersetzt I=1:2 H=60mm		DW 0261.2.10
MODULO MOTORIZZ. ASSIALE 2 USCITE IN Y MOLTIPLICATO I=1:2 H=70mm Axial geared-up I=1:2 single side twin head driven tool in Y H=70mm Axial angetriebenes Werkzeug 2 Ausgaenge in Y uebersetzt I=1:2 H=70mm		DW 0261.2.20

		PAGINA Page Seite
MODULO MOTORIZZ. ASSIALE 2 USCITE IN Y MOLTIPLICATO I=1:2 H=85mm Axial geared-up I=1:2 single side twin head driven tool in Y H=85mm Axial angetriebenes Werkzeug 2 Ausgaenge in Y uebersetzt I=1:2 H=85mm		DW 0261.2.30
MODULO MOTORIZZATO ASSIALE 2+2 USCITE IN Y H=60mm Axial multiple 2+2 outlet driven tool in Y H=60mm Axial angetriebenes Mehrspindel-Werkzeug 2+2 Ausgaenge in Y H=60mm		DW 0268.2.10
MODULO MOTORIZZATO ASSIALE 2+2 USCITE IN Y H=70mm Axial multiple 2+2 outlet driven tool in Y H=70mm Axial angetriebenes Mehrspindel-Werkzeug 2+2 Ausgaenge in Y H=70mm		DW 0268.2.20
MODULO MOTORIZZATO ASSIALE 2+2 USCITE IN Y H=85mm Axial multiple 2+2 outlet driven tool in Y H=85mm Axial angetriebenes Mehrspindel-Werkzeug 2+2 Ausgaenge in Y H=85mm		DW 0268.2.30
MODULO MOTORIZZATO ORIENTABILE ±90° H=54mm ±90° adjustable angle driven tool H=54mm Angetriebenes Werkzeug schwenkbar ±90° H=54mm		DW 0333.2.00
MODULO MOTORIZZ. ORIENTABILE ±90° CON NONIO DIGITALE H=54mm ±90° adjustable angle driven tool with digital display H=54mm Angetriebenes Werkzeug schwenkbar ±90° mit digital display H=54mm		DW 0333.2.01
MODULO MOTORIZZATO ORIENTABILE ±90° H=88,5mm ±90° adjustable angle driven tool H=88,5mm Angetriebenes Werkzeug schwenkbar ±90° H=88,5mm		DW 0333.2.10
MODULO MOTORIZZ. ORIENTABILE ±90° CON NONIO DIGITALE H=88,5mm ±90° adjustable angle driven tool with digital display H=88,5mm Angetriebenes Werkzeug schwenkbar ±90° mit digital display H=88,5mm		DW 0333.2.11
MODULO MOTORIZZATO ORIENTABILE ±90° H=47,5mm ±90° adjustable angle driven tool H=47,5mm Angetriebenes Werkzeug schwenkbar ±90° H=47,5mm		DW 0335.2.00
MODULO MOTORIZZ. ORIENTABILE ±90° CON NONIO DIGITALE H=47,5mm ±90° adjustable angle driven tool with digital display H=47,5mm Angetriebenes Werkzeug schwenkbar ±90° mit digital display H=47,5mm		DW 0335.2.01
MODULO MOTORIZZATO ORIENTABILE ±90° H=83mm ±90° adjustable angle driven tool H=83mm Angetriebenes Werkzeug schwenkbar ±90° H=83mm		DW 0335.2.10
MODULO MOTORIZZATO ORIENTABILE ±90° CON NONIO DIGITALE H=83mm ±90° adjustable angle driven tool with digital display H=83mm Angetriebenes Werkzeug schwenkbar ±90° mit digital display H=83mm		DW 0335.2.11

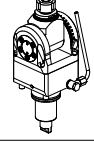
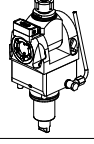
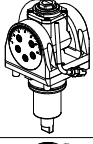
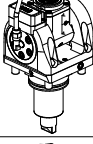
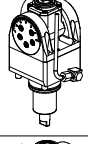
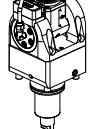
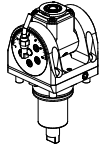
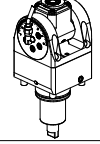
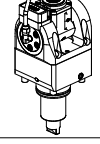
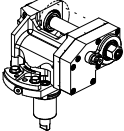
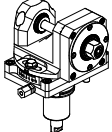
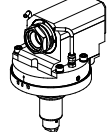
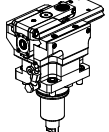
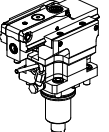
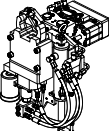
		PAGINA Page Seite
<p>MODULO MOTORIZZATO ORIENTABILE $\pm 90^\circ$ MOLTIPLICATO I=1:2 H=47,5mm $\pm 90^\circ$ adjustable angle driven tool geared-up I=1:2 H=47,5mm Angetriebenes Werkzeug schwenkbar $\pm 90^\circ$ uebersetzt I=1:2 H=47,5mm</p>		DW 0336.2.00
<p>MOD. MOT. ORIENTAB. $\pm 90^\circ$ MOLTIPL. I=1:2 CON NONIO DIGITALE H=47,5mm $\pm 90^\circ$ adjustable angle driven tool geared-up I=1:2 with digital display H=47,5mm Angetr. Werkzeug schwenkbar $\pm 90^\circ$ uebersetzt I=1:2 mit digital display H=47,5mm</p>		DW 0336.2.01
<p>MODULO MOTORIZZATO ORIENTABILE $\pm 90^\circ$ MOLTIPLICATO I=1:2 H=83mm $\pm 90^\circ$ adjustable angle driven tool geared-up I=1:2 H=83mm Angetriebenes Werkzeug schwenkbar $\pm 90^\circ$ uebersetzt I=1:2 H=83mm</p>		DW 0336.2.10
<p>MOD. MOT. ORIENTABILE $\pm 90^\circ$ MOLTIPL. I=1:2 CON NONIO DIGITALE H=83mm $\pm 90^\circ$ adjustable angle driven tool geared-up I=1:2 with digital display H=83mm Angetrieb. Werkzeug schwenkbar $\pm 90^\circ$ uebersetzt I=1:2 mit digital display H=83mm</p>		DW 0336.2.11
<p>MODULO MOTORIZZATO PORTACREATORE Driven gear hobber Angetriebenes Zahnradwaelzfraes-Werkzeug</p>		DW 0340.2.00
<p>MODULO MOTORIZZATO PORTACREATORE RADIALE Radial driven gear hobber Radial Angetriebenes Zahnradwaelzfraes-Werkzeug</p>		DW 0340.2.30
<p>MODULO MOTORIZZATO ASSIALE MTSK PER POWER SKIVING H=90mm Axial MTSK driven tool for Power Skiving H=90mm Axial MTSK angetriebenes Werkzeug fuer Power Skiving H=90mm</p>		DW 0350.2.00.K
<p>MODULO MOTORIZZATO PER VITI SENZA FINE Driven tool for worm screws Angetriebenes werkzeug für schrauben ohne ende</p>		DW 0359.2.00
<p>MODULO MOTORIZZATO STOZZATORE CORSA 50mm H=85mm Slotting driven tool 50mm stroke H=85mm Keilnutenstossmaschine 50mm Hub H=85mm</p>		DW 0360.2.00
<p>MODULO MOTORIZZATO STOZZATORE CORSA 25mm H=85mm Slotting driven tool 25mm stroke H=85mm Keilnutenstossmaschine 25mm Hub H=85mm</p>		DW 0360.2.01
<p>MODULO MOTORIZZATO PER LUNETTA REATRATILE (TAGLIA 1) Driven toolholder for sliding steady rest (Size 1) Luenettenwerkzeug zurueck versetzte Version (Groesse 1)</p>		DW 0363.2.00

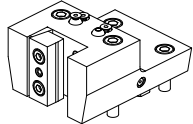
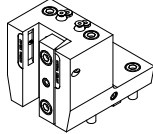
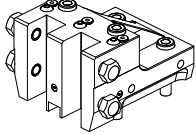
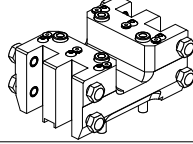
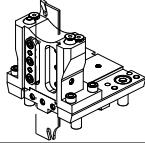
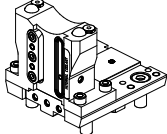
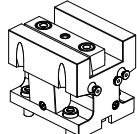
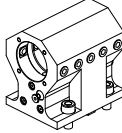
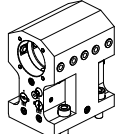
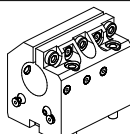
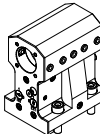
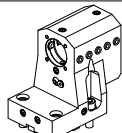
		PAGINA Page Seite
PORTAUTENSILE RADIALE SINGOLO QD=25mm / QD=1" H=60mm Radial single static tool QD=25mm / QD=1" H=60mm Radial Single-Werkzeughalter QD=25mm / QD=1" H=60mm		DW 0423.2.00
PORTAUTENSILE RADIALE SINGOLO QD=25mm H=100mm Radial single static tool QD=25mm H=100mm Radial Single-Werkzeughalter QD=25mm H=100mm		DW 0423.2.10
PORTAUTENSILE RADIALE SOVRAPPOSTO QD=25mm / QD=1" Radial single side twin static tool QD=25mm / QD=1" Radial Werkzeughalter ueberlagert QD=25mm / QD=1"		DW 0442.2.00
PORTAUT. RADIALE DOPPIO SOVRAP. QD=20mm / QD=3/4" / QD=25mm / QD=1" Radial double side twin static tool QD=20mm / QD=3/4" / QD=25mm / QD=1" Radial Doppel-Werkzeughalter ueberlagert QD=20mm / QD=3/4" / QD=25mm / QD=1"		DW 0463.2.00
PORTAUTENSILE RADIALE PER LAMA Radial blade holder Radial Abstechhalter		DW 0520.2.01
PORTAUTENSILE RADIALE PER LAMA CON LUBRIFICAZIONE INTERNA Radial blade holder with internal coolant Radial Abstechhalter mit Innenkuehlung		DW 0520.2.05
PORTAUTENSILE ASSIALE SINGOLO QD=25mm / QD=1" Axial single static tool QD=25mm / QD=1" Axial Single-Werkzeughalter QD=25mm / QD=1"		DW 0552.2.00
PORTAUTENSILE ASSIALE PER BARENO Ø 50mm / Ø 2" H=75mm Axial single boring bar holder Ø50mm / Ø2" H=75mm Axial Bohrhalter Ø50mm / Ø2" H=75mm		DW 0610.2.10
PORTAUTENSILE ASSIALE PER BARENO Ø 50mm / Ø 2" H=100mm Axial single boring bar holder Ø50mm / Ø2" H=100mm Axial Bohrhalter Ø50mm / Ø2" H=100mm		DW 0620.2.10
PORTAUTENSILE ASSIALE PER BARENO Ø 40mm / Ø 1 1/2" H=60mm Axial single boring bar holder Ø40mm / Ø1 1/2" H=60mm Axial Bohrhalter Ø40mm / Ø1 1/2" H=60mm		DW 0630.2.20
PORTAUTENSILE ASSIALE PER BARENO Ø 40mm / Ø 1 1/2" H=100mm Axial single boring bar holder Ø40mm / Ø1 1/2" H=100mm Axial Bohrhalter Ø40mm / Ø1 1/2" H=100mm		DW 0640.2.10
PORTAUTENSILE ASSIALE ARRETRATO PER BARENO Ø 40mm H=100mm Axial rear set boring bar holder Ø40mm H=100mm Axial Bohrhalter zurueckversetzt Ø40mm H=100mm		DW 0840.2.10

		PAGINA Page Seite
<p>PORTAUT. ASSIALE PER BARENO 2 POSIZIONI ϕ 25mm / ϕ1" / ϕ1 1/4" / ϕ 32mm Axial double boring bar holder ϕ25mm / ϕ1" / ϕ1 1/4" / ϕ32mm Axial Bohrhalter 2 positionen ϕ25mm / ϕ1" / ϕ1 1/4" / ϕ32mm</p>		DW 0862.2.00
<p>PORTAUTENSILE ASSIALE PER BARENO 4+4 POSIZIONI ϕ 20mm / ϕ 3/4" Axial 4+4 position boring bar holder ϕ20mm / ϕ3/4" Axial Bohrhalter 4+4 Positionen ϕ20mm / ϕ3/4"</p>		DW 0924.2.00
<p>CONTROPUNTA PER CONTROMANDRINO Tailstock for subspindle Gegenspitz fuer Gegenspindel</p>		DW 0950.2.00

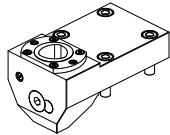
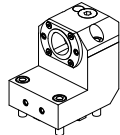
<p>PORTAUTENSILE RADIALE SINGOLO ARRETRATO MT CAPTO Radial single rear-set static tool MT CAPTO Radial Single-Werkzeughalter zurueckversetzt MT CAPTO</p>		DW 0430.B.40
<p>PORTAUTENSILE ASSIALE SINGOLO ARRETRATO MT CAPTO Axial single rear-set static tool MT CAPTO Axial Single-Werkzeughalter zurueckversetzt MT CAPTO</p>		DW 0555.B.40

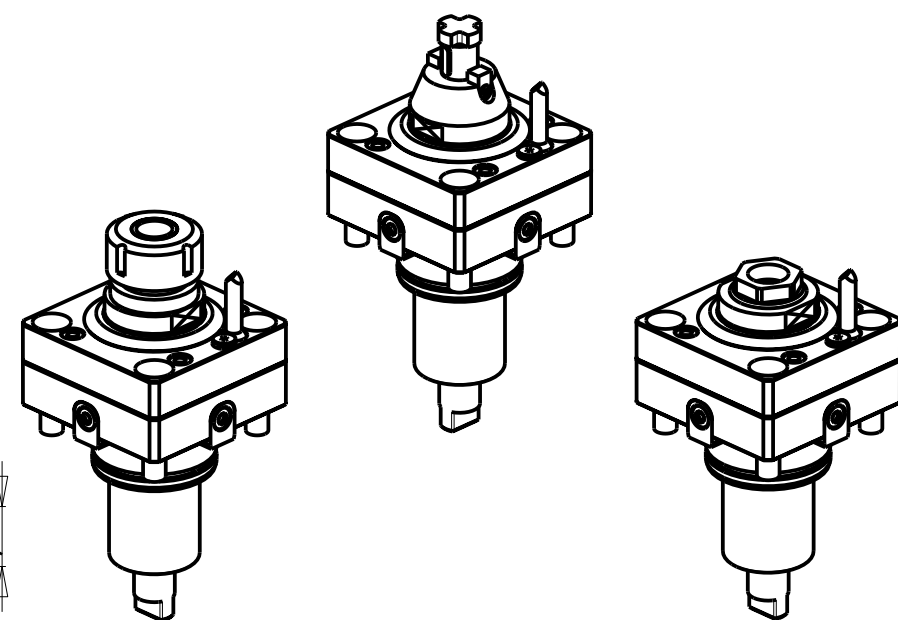
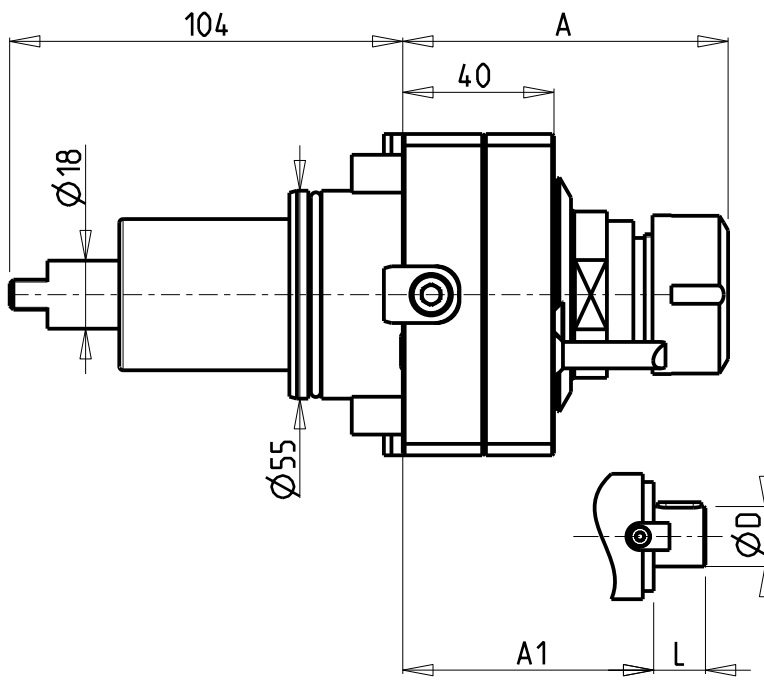
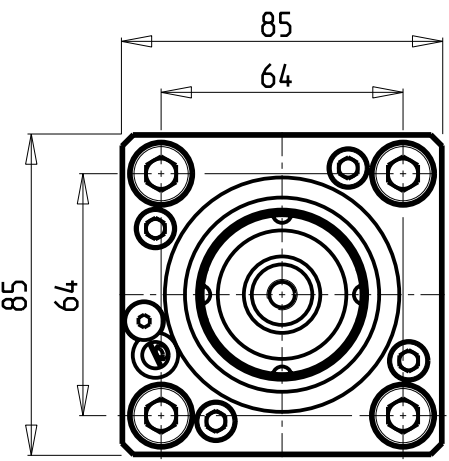

ATTENZIONE - ATTENTION - ACHTUNG

- FINO AD ESAURIMENTO SCORTE

- clearance sale

- solange vorrat

- Chiave inclusa
- Key included
- Schluessel einbegriffen

Cod. MT	Cod. EPPINGER	Mandrino Spindle Spindel	I	RPM	Coppia Max Max Torque Max Drehmoment	Lubrificazione int. Coolant through Innenkuehlung	Lubrificazione est. Ext. coolant Ausenkuehlung	A	A1	D	L	CHIAVI NON INCLUSE Keys not included Schluessel nicht einbegriffen	
0271325	-	ER25	1:1	6000	50Nm	-	X	86.06	-	-	-	CHSTER25	CHUB40 o 0270018
0271525	7.070.679	ER A 25	1:1	6000	50Nm	-	X	63.03	-	-	-	CHUB27	CHUB40 o 0270018
0271025	-	ER A 25	1:1	6000	50Nm	P=30bar	X	63.03	-	-	-	CHUB27	CHUB40 o 0270018
0271617	-	Ø16x17	1:1	6000	50Nm	-	X	-	70	16	17	CH_VTCROCE_M08	CHUB40 o 0270018
0272219	-	Ø22x19	1:1	6000	50Nm	-	X	-	70	22	19	CH_VTCROCE_M10	CHUB40 o 0270018

DOOSAN BMT 55

MOD: PUMA 230-240M/MS-280LM - PUMA 1500-2000-2500M/MS/Y/SY - LINX 300 M - PUMA 2100 12ST. - PUMA 2600 16ST. - PUMA H250TM
 PUMA TW2600 10ST. - PUMA TT1500-1800-2100MS/SY/SYY - PUMA TL2000-2500 (M) - MX1600/2100ST 12ST. - PUMA GT2100-2600 M - PUMA QL200HM

MODULO MOTORIZZATO RADIALE
 Radial driven tool
 Radial angetriebenes Werkzeug

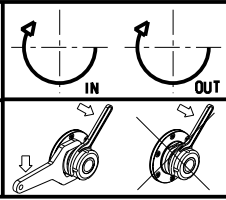

M.T. srl
 Via Casino Albini 480
 Tel. 0541/956034-957884
 Fax 0541/956341
 47842 S. GIOVANNI IN M. (RN)
 e-mail: mtma@mtmarchetti.com
 http://www.mtmarchetti.com

PRODUZIONE MODULI ROTANTI

PAGINA DW0010-2-00

Subject to change without notice.

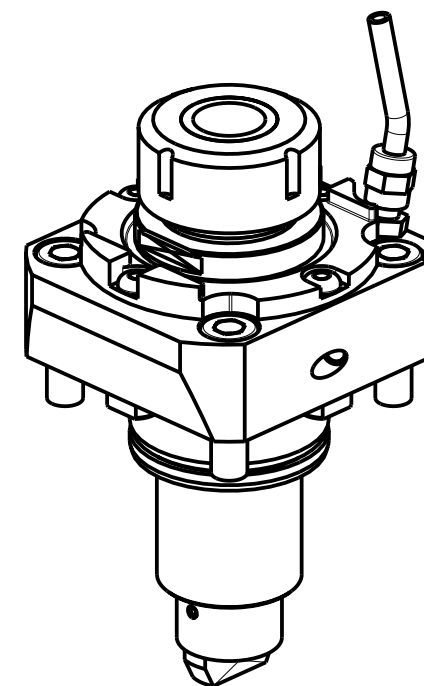
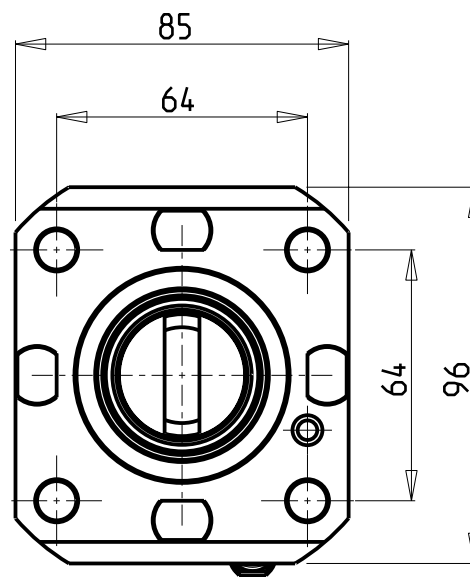
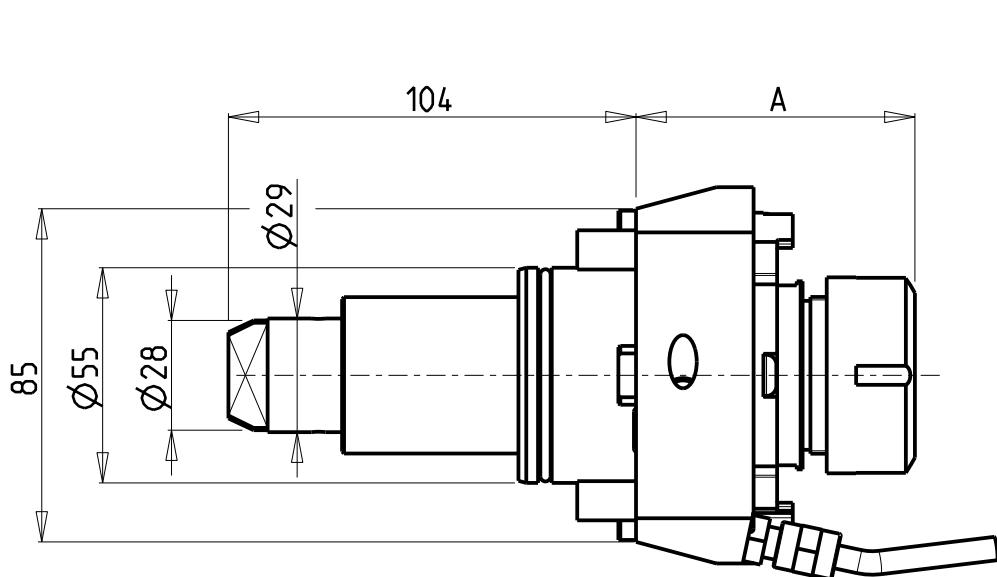

Cod. MT	Mandrino Spindle Spindel	I	RPM	Coppia Max Max Torque Max Drehmoment	Lubrificazione int. Coolant through Innenkuehlung	Lubrificazione est. Ext. coolant Aussenkuehlung	A	CHIAVI NON INCLUSE Keys not included Schluessel nicht einbegriffen		
DW 00901325	ERA25	1:1	6000	50Nm	-	X	42.5	CHUB27	CHTAER25ZC	OKU0650004
DW 00901425	ERA25	1:1	6000	50Nm	P=30bar	X	54.5	CHUB27	CHTAER25ZC	OKU0650004
DW 00901132	ER32	1:1	6000	50Nm	-	X	71.2	CHSTER32	-	OKU0650004
DW 00901232	ER32	1:1	6000	50Nm	P=30bar	X	79.2	CHSTER32	-	OKU0650004
DW 00901332	ERA32	1:1	6000	50Nm	-	X	54.5	CHUB30	CHTAER32ZC	OKU0650004
DW 00901432	ERA32	1:1	6000	50Nm	P=30bar	X	62.5	CHUB30	CHTAER32ZC	OKU0650004

- Chiave inclusa
- Key included
- Schluessel inbegriffen

DOOSAN BMT 55

MOD: PUMA 230-240M/MS-280LM - PUMA 1500-2000-2500M/MS/Y/SY - LINX 300 M - PUMA 2100 12ST. - PUMA 2600 16ST. - PUMA H250TM
PUMA TW2600 10ST. - PUMA TT1500-1800-2100MS/SY/SYY - PUMA TL2000-2500 (M) - MX1600/2100ST 12ST. - PUMA GT2100-2600 M - PUMA QL200HM

MODULO MOTORIZZATO RADIALE

Radial driven tool

Radial angetriebenes Werkzeug

Subject to change without notice.

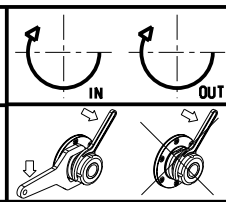

M.T. srl

Via Casino Albini 480
Tel. 0541/956034-957884
Fax 0541/956341

47842 S. GIOVANNI IN M. (RN)
e-mail: mtma@mtmarchetti.com
http://www.mtmarchetti.com

PRODUZIONE MODULI ROTANTI



PAGINA DW0010-2-01

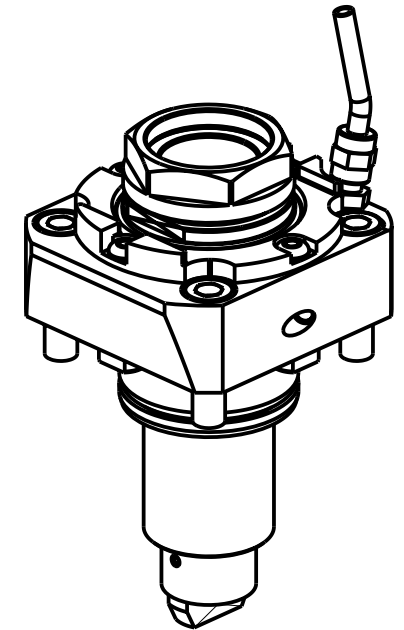
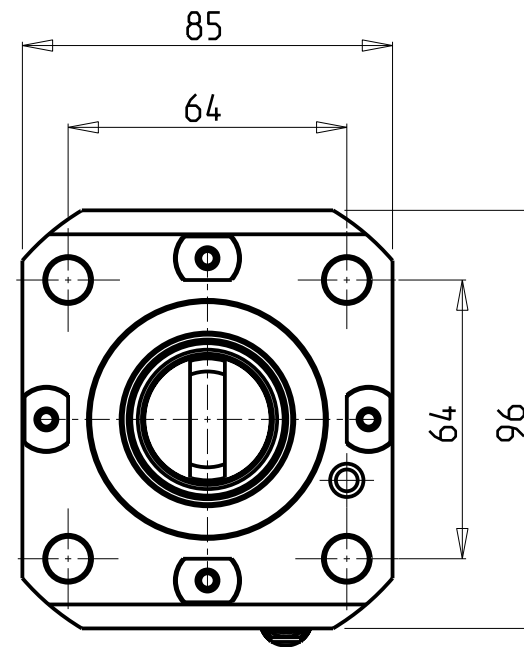
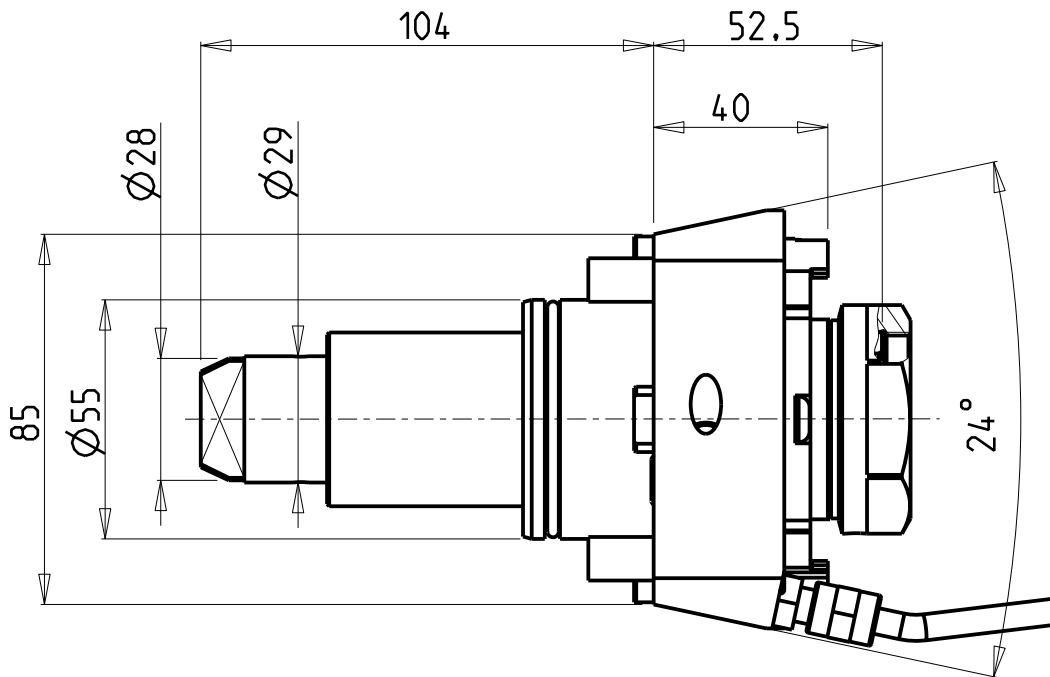

PER PORTAUTENSILI MODULARI MTSK-40 VEDI PAG. TBL300-1-40
 FOR MTSK-40 QUICK CHANGE TOOLHOLDERS CLAMPINGS SEE PAGE TBL300-1-40
 FUER MTSK-40 MODULARE WERKZEUGAUFNAHMEN SIEHE SEITE TBL300-1-40

- Chiave inclusa
- Key included
- Schluessel inbegriffen

Cod. MT	Mandrino Spindle Spindel	I	RPM	Coppia Max Max Torque Max Drehmoment	Lubrificazione est. Ext. coolant Aussenkuehlung	Lubrificazione int. Coolant through Innenkuehlung	CHIAVI NON INCLUSE Keys not included Schluessel nicht einbegriffen	
DW00801140	MTSK-40	1:1	6000	50Nm	X	-	CHUB46	OKU0650004 ■
DW00800240	MTSK-40	1:1	6000	50Nm	X	P=30bar	CHUB46	OKU0650004 ■

DOOSAN BMT 55

MOD: PUMA 230-240M/MS-280LM - PUMA 1500-2000-2500M/MS/Y/SY - LINX 300 M - PUMA 2100 12ST. - PUMA 2600 16ST. - PUMA H250TM
 PUMA TW2600 10ST. - PUMA TT1500-1800-2100MS/SY/SYY - PUMA TL2000-2500 (M) - MX1600/2100ST 12ST. - PUMA GT2100-2600 M - PUMA QL200HM

MODULO MOTORIZZATO RADIALE MTSK
 Radial MTSK driven tool
 Radial MTSK angetriebenes Werkzeug

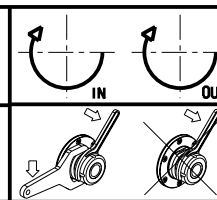

M.T. srl
 Via Casino Albini 480
 Tel. 0541/956034-957884
 Fax 0541/956341
 47842 S. GIOVANNI IN M. (RN)
 e-mail: mtma@mtmarchetti.com
 http://www.mtmarchetti.com

PRODUZIONE MODULI ROTANTI



PAGINA DW0010-2-01-K

Subject to change without notice.

04/2020

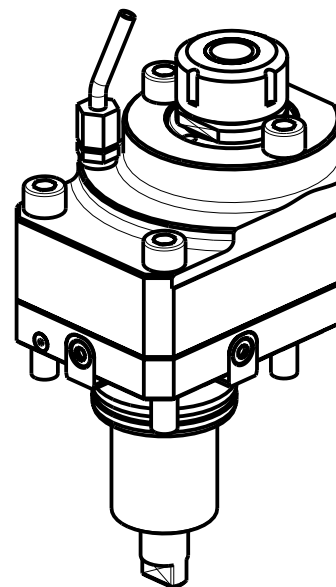
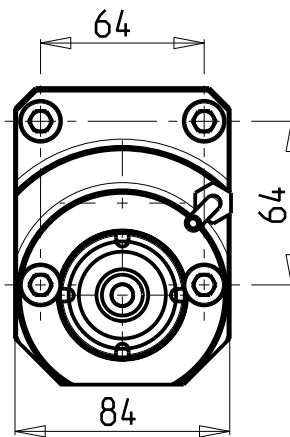
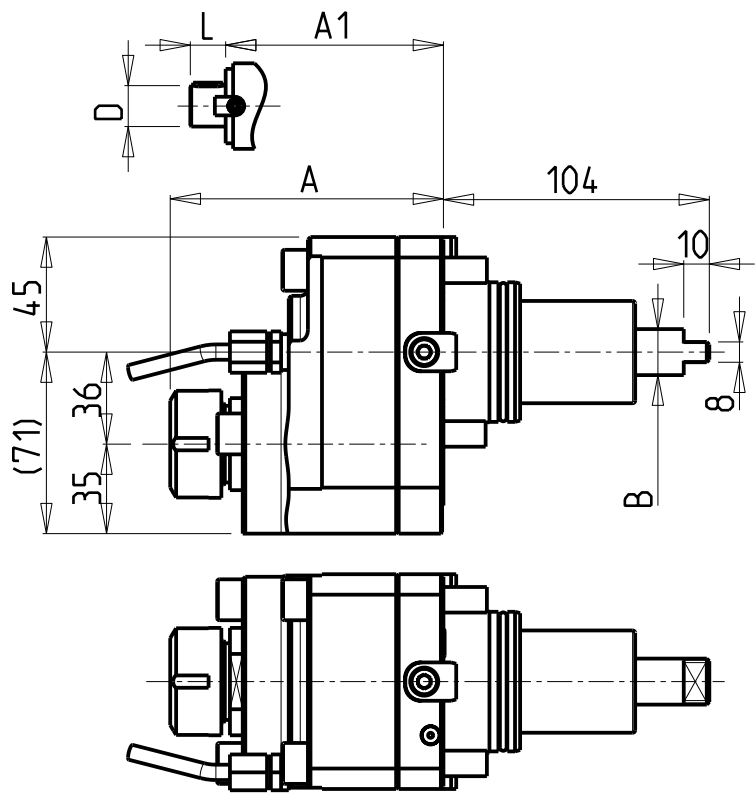

ATTENZIONE - ATTENTION - ACHTUNG

- VERIFICARE LE MISURE DI INGOMBRO PER POSSIBILE INTERFERENZA SU ALCUNI MODELLI DI MACCHINE
- Please check the overall sizes for possible interferences on some machine models
- Bitte überprüfen sie das ausmass um mögliche interferenzen auf einigen maschinen modellen zu vermeiden

- Chiave inclusa
- Key included
- Schlüssel inbegriffen

Cod. MT	Mandrino Spindle Spindel	I	RPM	Coppia Max Max Torque Max Drehmoment	Reversibile lato mandrino/contromandrino Reversible sub/main spindle side Umkehrbare Spindel-seite/ Gegenspindel-seite	Lubrificazione int. Coolant through Innenkuehlung	Lubrificazione est. Ext. coolant Aussenkuehlung	A	B	A1	D	L	CHIAVI NON INCLUDE Keys not included Schlüssel nicht einbegriffen	
													CH_VTCROCE_M08	MNLO210007
0720025	ER25	1:1	6000	50Nm	X	-	X	106.86	20	-	-	-	CHSTER25	MNLO210007
0720032	ER32	1:1	6000	50Nm	X	-	X	120.56	20	-	-	-	CHSTER32	MNLO210007
DW 02710420	ERA20	1:1	6000	50Nm	X	P=70bar	X	94.5	29	-	-	-	CHTAER20ZC	MNLO210007
0720016	∅16x17	1:1	6000	50Nm	X	-	X	-	20	88.5	16	17	CH_VTCROCE_M08	MNLO210007
0720022	∅22x19	1:1	6000	50Nm	X	-	X	-	20	90.5	22	19	CH_VTCROCE_M10	MNLO210007
0720027	∅27x21	1:1	6000	50Nm	X	-	X	-	20	92.5	27	21	CH_VTCROCE_M12	MNLO210007

DOOSAN BMT 55

MOD: PUMA 230-240M/MS-280LM - PUMA 1500-2000-2500M/MS/Y/SY - LINX 300 M - PUMA 2100 12ST. - PUMA 2600 16ST. - PUMA H250TM
 PUMA TW2600 10ST. - PUMA TT1500-1800-2100MS/SY/SYY - PUMA TL2000-2500 (M) - MX1600/2100ST 12ST. - PUMA GT2100-2600 M - PUMA QL200HM

MODULO MOTORIZZATO RADIALE DISASSATO IN Z 36mm
 Radial driven tool re-directed in Z by 36mm
 Radial angetriebenes Werkzeug achsversetzt in Z um 36mm

Subject to change without notice.

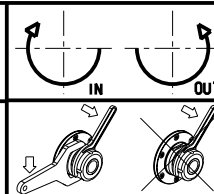

M.T. srl

Via Casino Albini 480
 Tel. 0541/956034-957884
 Fax 0541/956341
 47842 S. GIOVANNI IN M. (RN)
 e-mail: mtma@mtmarchetti.com
 http://www.mtmarchetti.com

PRODUZIONE MODULI ROTANTI



PAGINA DW0030-2-10

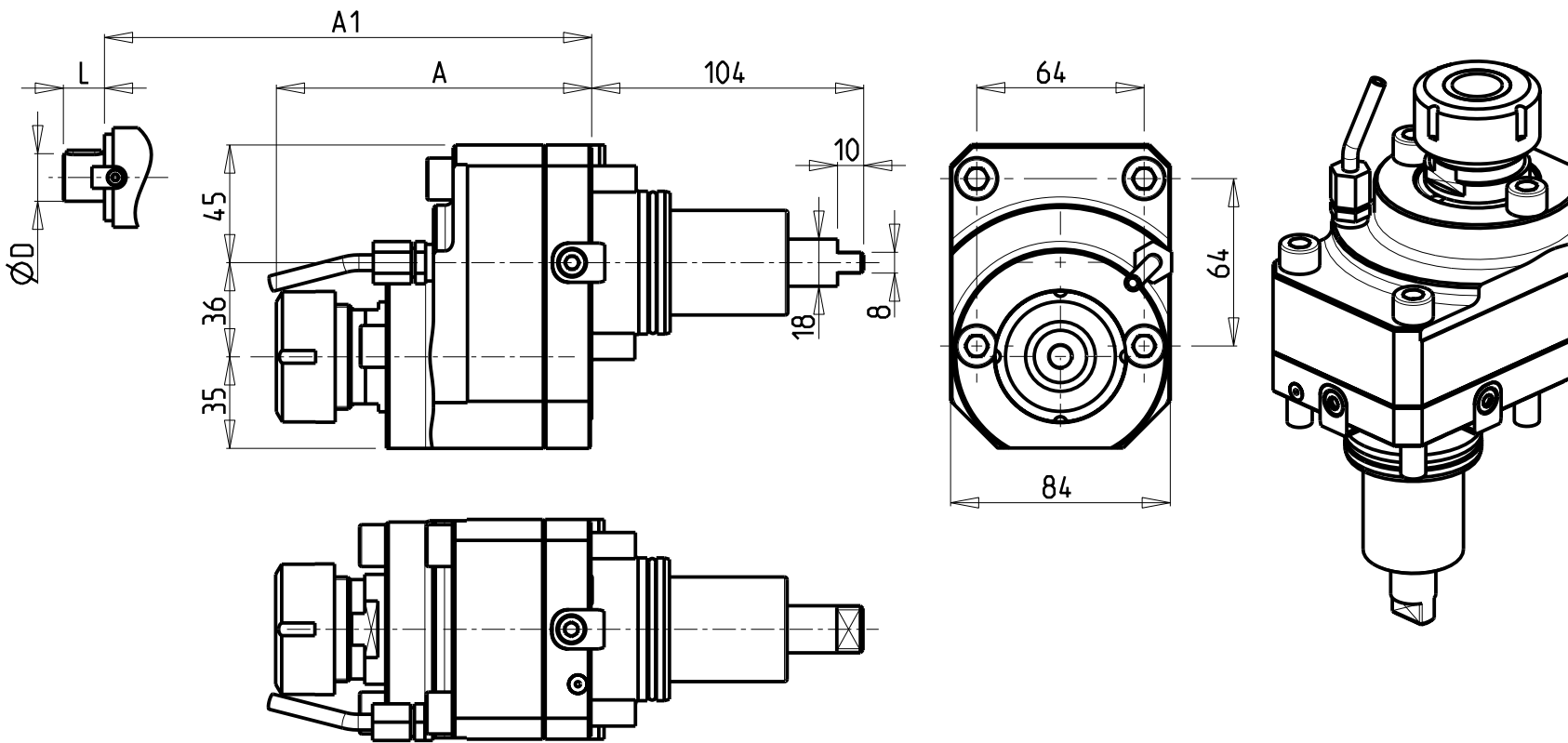

ATTENZIONE - ATTENTION - ACHTUNG

- VERIFICARE LE MISURE DI INGOMBRO PER POSSIBILE INTERFERENZA SU ALCUNI MODELLI DI MACCHINE
- Please check the overall sizes for possible interferences on some machine models
- Bitte überprüfen sie das ausmass um mögliche interferenzen auf einigen maschinen modellen zu vermeiden

- Chiave inclusa
- Key included
- Schluessel inbegriffen

Cod. MT	Mandrino Spindle Spindel	I	RPM	Coppia Max Max Torque Max Drehmoment	Reversibile lato mandrino/contromandrino Reversible sub/main spindle side Umkehrbare Spindelseite/ Gegenspindelseite	Lubrificazione est. Ext. coolant Aussenkuehlung	A	A1	D	L	CHIAVI NON INCLUSE Keys not included Schluessel nicht einbegriffen	
0722132	ER32	2:1	3000	65Nm	X	X	120.56	-	-	-	CHSTER32	MNL0210007
0722116	Ø16x17	2:1	3000	65Nm	X	X	-	88.5	16	17	CH_VTCROCE_M08	MNL0210007
0722122	Ø22x19	2:1	3000	65Nm	X	X	-	90.5	22	19	CH_VTCROCE_M10	MNL0210007
0722127	Ø27x21	2:1	3000	65Nm	X	X	-	92.5	27	21	CH_VTCROCE_M12	MNL0210007

DOOSAN BMT 55

MOD: PUMA 230-240M/MS-280LM - PUMA 1500-2000-2500M/MS/Y/SY - LINX 300 M - PUMA 2100 12ST. - PUMA 2600 16ST. - PUMA H250TM
 PUMA TW2600 10ST. - PUMA TT1500-1800-2100MS/SY/SYY - PUMA TL2000-2500 (M) - MX1600/2100ST 12ST. - PUMA GT2100-2600 M - PUMA QL200HM

MODULO MOTORIZZATO RADIALE RIDOTTO I=2:1 DISASSATO IN Z 36mm

Radial geared-down I=2:1 driven tool re-directed in Z by 36mm

Radial angetriebenes Werkzeug untersetzt I=2:1 achsversetzt in Z um 36mm

Subject to change without notice.

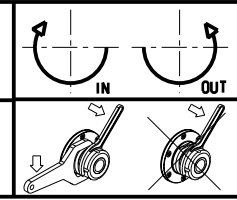

M.T. srl

Via Casino Albini 480
 Tel. 0541/956034-957884
 Fax 0541/956341
 47842 S. GIOVANNI IN M. (RN)
 e-mail: mtma@mtmarchetti.com
 http://www.mtmarchetti.com

PRODUZIONE MODULI ROTANTI



PAGINA DW0030-2-20

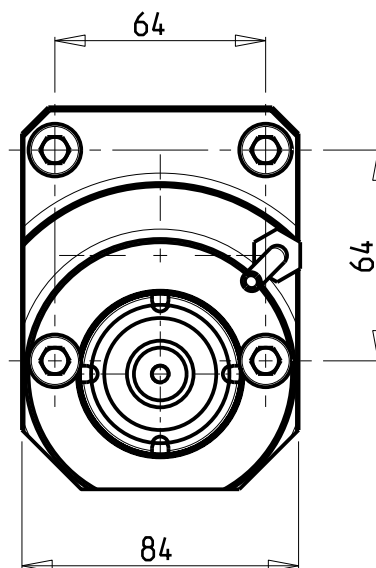
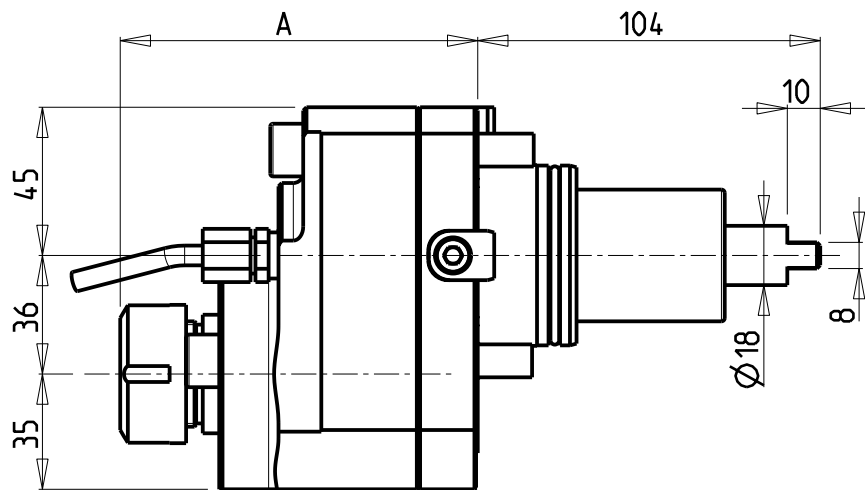

ATTENZIONE - ATTENTION - ACHTUNG

- VERIFICARE LE MISURE DI INGOMBRO PER POSSIBILE INTERFERENZA SU ALCUNI MODELLI DI MACCHINE
- Please check the overall sizes for possible interferences on some machine models
- Bitte überprüfen sie das ausmass um mögliche interferenzen auf einigen maschinen modellen zu vermeiden

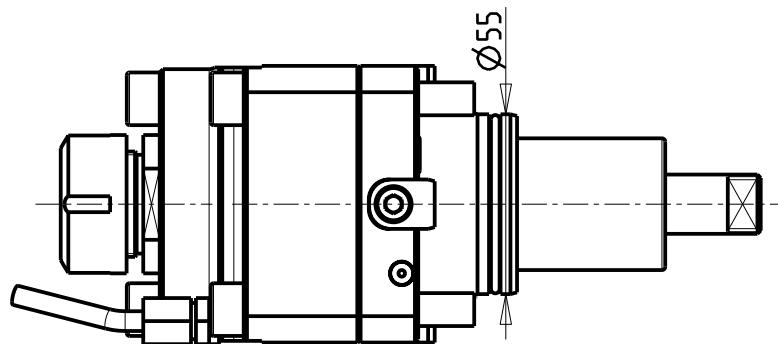
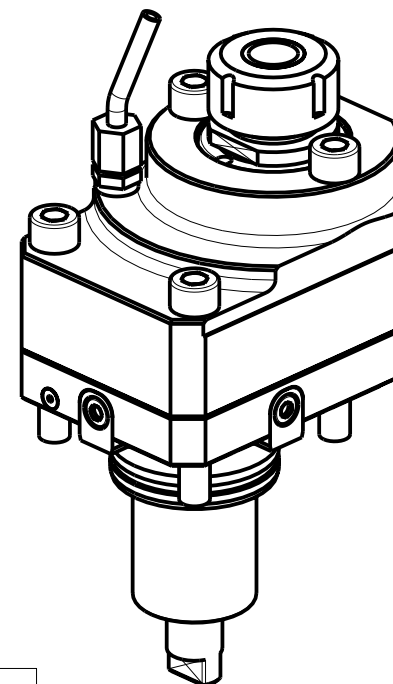

Cod. MT	Mandrino Spindle Spindel	I	RPM	Coppia Max Max Torque Max Drehmoment	Reversibile lato mandrino/contromandrino Reversible sub/main spindle side Umkehrbare Spindel-seite/Gegenspindel-seite	Lubrificazione est. Ext. coolant Auslenkuehlung	A	CHIAVI NON INCLUSE Keys not included Schluessel nicht einbegriffen	
0721225	ER25	1:2	12000	30Nm	X	X	108.56	CHSTER25	MNL0210007

DOOSAN BMT 55

MOD: PUMA 230-240M/MS-280LM - PUMA 1500-2000-2500M/MS/Y/SY - LINX 300 M - PUMA 2100 12ST. - PUMA 2600 16ST. - PUMA H250TM
 PUMA TW2600 10ST. - PUMA TT1500-1800-2100MS/SY/SYY - PUMA TL2000-2500 (M) - MX1600/2100ST 12ST. - PUMA GT2100-2600 M - PUMA QL200HM

MODULO MOTORIZZATO RADIALE Moltiplicato I=1:2 DISASSATO IN Z 36mm
 Radial geared-up I=1:2 driven tool re-directed in Z by 36mm
 Radial angetriebenes Werkzeug uebersetzt I=1:2 achsversetzt in Z um 36mm

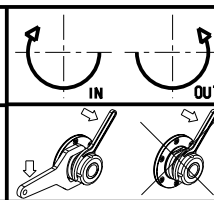

M.T. srl
 Via Casino Albini 480
 Tel. 0541/956034-957884
 Fax 0541/956341
 47842 S. GIOVANNI IN M. (RN)
 e-mail: mtma@mtmarchetti.com
 http://www.mtmarchetti.com

PRODUZIONE MODULI ROTANTI



PAGINA DW0030-2-30

Subject to change without notice.

04/2020

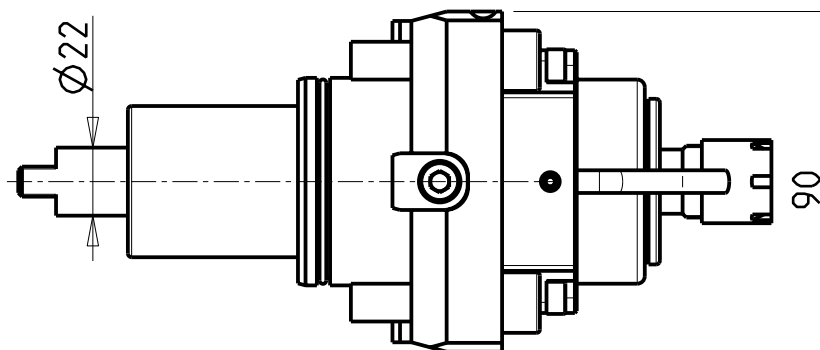
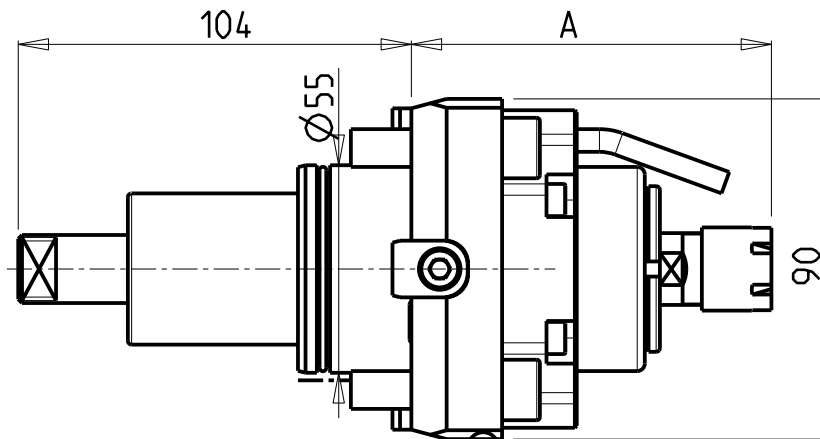
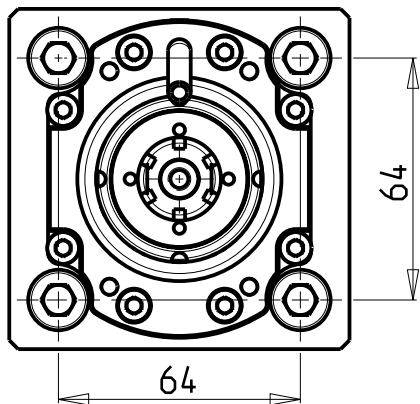

ATTENZIONE - ATTENTION - ACHTUNG

- Per lo smontaggio degli utensili utilizzare sempre la chiave di contrasto come indicato nel manuale d'uso.
- For disassembly of the tools use always the contrast key as mentioned in the user instructions.
- Fuer das Abmontieren der Werkzeuge immer den Gegenschlüssel benutzen wie in der Bedienungsanleitung erwäehnt.

ATTENZIONE - ATTENTION - ACHTUNG

- VERIFICARE LE MISURE DI INGOMBRO PER POSSIBILE INTERFERENZA SU ALCUNI MODELLI DI MACCHINE
- Please check the overall sizes for possible interferences on some machine models
- Bitte überprüfien sie das ausmass um mögliche interferenzen auf einigen maschinen modellen zu vermeiden

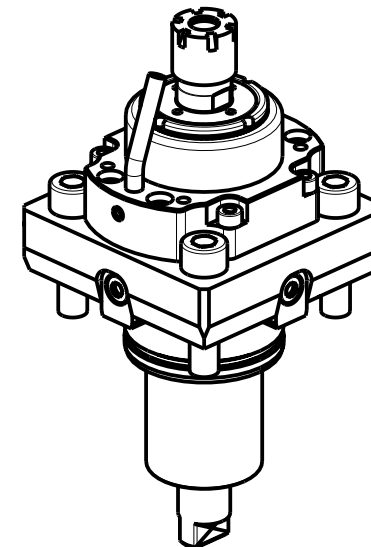

ATTENZIONE - ATTENTION - ACHTUNG

- PRIMA DI UTILIZZARE IL MOTORIZZATO CONSULTARE LE ISTRUZIONI ALLEGATE!
- BEFORE USING THE DRIVEN TOOL, PLEASE CHECK THE ENCLOSED INSTRUCTION SHEET!
- VOR DER BENUTZUNG DES ANGETRIEBENEN WERKZEUGES, DIE BEILIEGENDEN INSTRUKTIONEN DURCHLESEN!

Cod. MT	Mandrino Spindle Spindel	I	RPM	Coppia Max Max Torque Max Drehmoment	Lubrificazione int. Coolant through Innenkuehlung	Lubrificazione est. Ext. coolant Ausssenkuehlung	A	CHIAVI INCLUSE Keys included Schluessel einbegriffen	
DW 00600116	ER16	1:5.625	22500	6Nm		X	95.25	CHMNER16	CHUB17
DW 00600111	ER11	1:5.625	22500	6Nm	P=30bar	X	107.45	CHMNER11	CHUB11

DOOSAN BMT 55

MOD: PUMA 230-240M/MS-280LM - PUMA 1500-2000-2500M/MS/Y/SY - LINX 300 M - PUMA 2100 12ST. - PUMA 2600 16ST. - PUMA H250TM
 PUMA TW 2600 10ST. - PUMA TT1500-1800-2100MS/SY/SYY - PUMA TL2000-2500 (M) - MX1600/2100ST 12ST. - PUMA GT2100-2600 M - PUMA QL200HM

MODULO MOTORIZZATO RADIALE MOLTIPLICATO I=1:5.625

Radial geared-up I=1:5.625 driven tool

Radial angetriebenes Werkzeug uebersetzt I=1:5.625

Subject to change without notice.

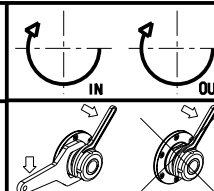

M.T. srl

Via Casino Albini 480
 Tel. 0541/956034-957884
 Fax 0541/956341
 47842 S. GIOVANNI IN M. (RN)
 e-mail: mtma@mtmarchetti.com
 http://www.mtmarchetti.com

PRODUZIONE MODULI ROTANTI



PAGINA DW 0060-2-00

ATTENZIONE - ATTENTION - ACHTUNG

- Per lo smontaggio degli utensili utilizzare sempre la chiave di contrasto come indicato nel manuale d'uso.
- For disassembly of the tools use always the contrast key as mentioned in the user instructions.
- Fuer das Abmontieren der Werkzeuge immer den Gegenschlüssel benutzen wie in der Bedienungsanleitung erwaeht.

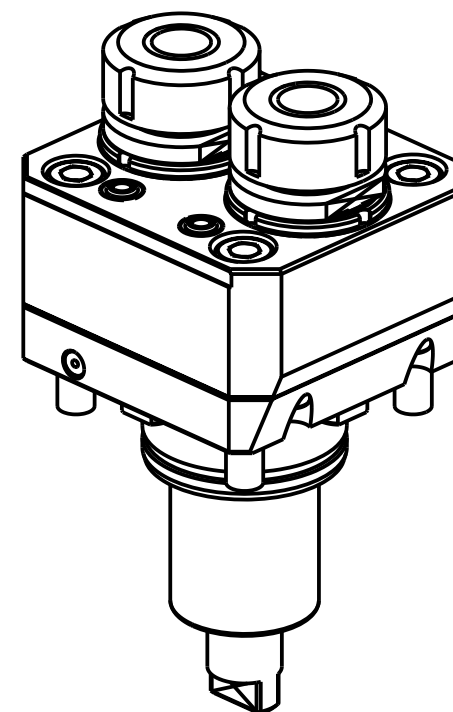
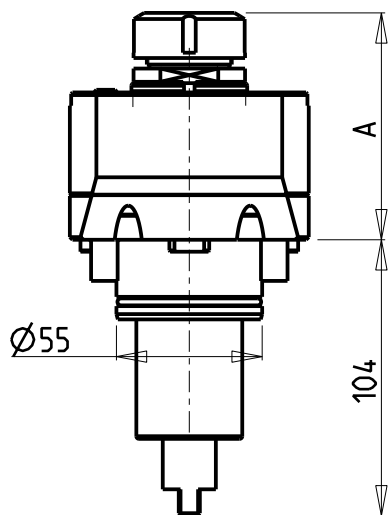
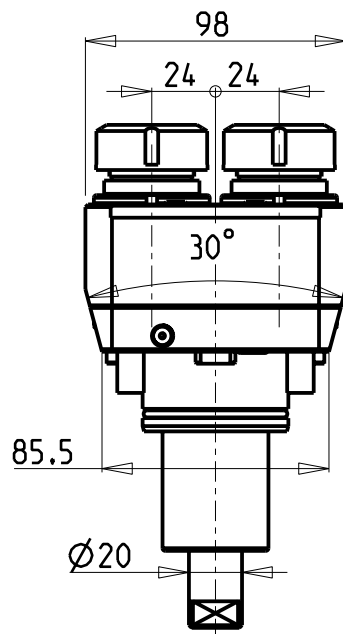
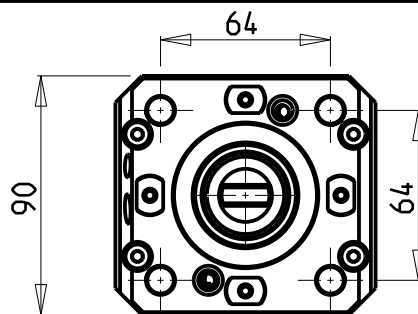

Cod. MT	Mandrino Spindle Spindel	I	RPM	Coppia Max Max Torque Max Drehmoment	Lubrificazione est. Ext. coolant Aussenkuehlung	A	CHIAVI NON INCLUSE Keys not included Schlüssel nicht einbegriffen	
0730016X2	ER16	1:1	6000	30Nm	X	84.5	CHMNER16	CHUB17
0730025X2	ER25	1:1	6000	30Nm	X	85	CHSTER25	MNLO210007

DOOSAN BMT 55

MOD: PUMA 1500-2000-2500M/MS/Y/SY - PUMA 2100 12ST. - PUMA TT1500-1800-2100MS/SY/SYY - PUMA TL2000-2500 (M)

MODULO MOTORIZZATO RADIALE 2 USCITE IN Y
Radial single side twin head driven tool in Y
Radial angetriebenes Werkzeug 2 Ausgaenge in Y

Subject to change without notice.

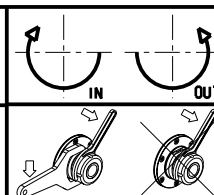

M.T. srl

Via Casino Albini 480
Tel. 0541/956034-957884
Fax 0541/956341
47842 S. GIOVANNI IN M. (RN)
e-mail: mtma@mtmarchetti.com
http://www.mtmarchetti.com

PRODUZIONE MODULI ROTANTI



PAGINA DW 0080-2-00

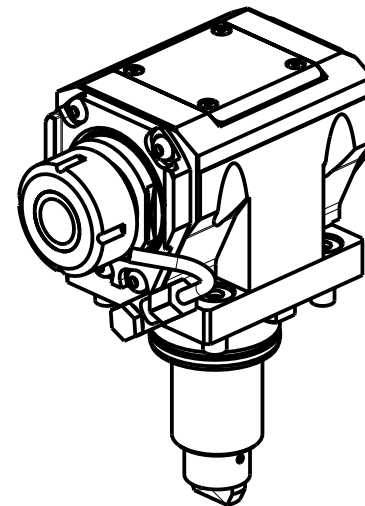
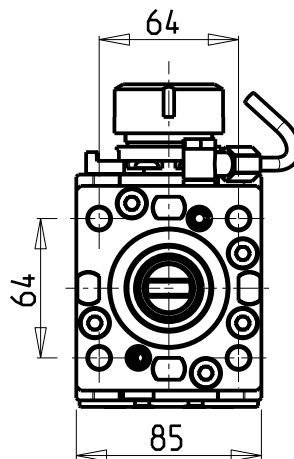
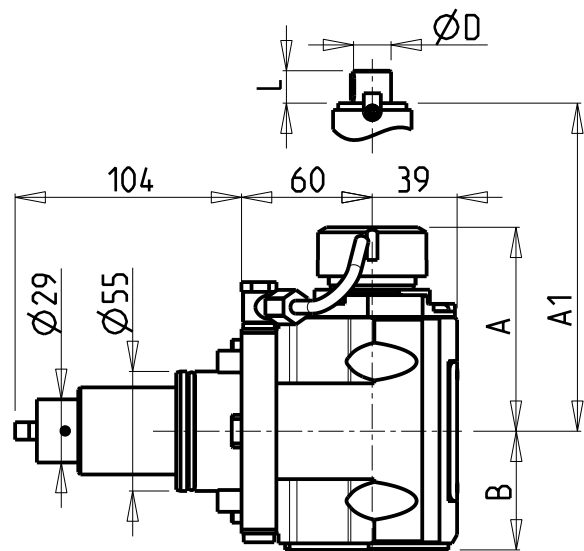

ATTENZIONE - ATTENTION - ACHTUNG

- VERIFICARE LE MISURE DI INGOMBRO PER POSSIBILE INTERFERENZA SU ALCUNI MODELLI DI MACCHINE
- Please check the overall sizes for possible interferences on some machine models
- Bitte überprüfen sie das ausmass um mögliche interferenzen auf einigen maschinen modellen zu vermeiden

- Chiave inclusa
- Key included
- Schlüssel inbegriffen

Cod. MT	Mandrino Spindle Spindel	I	RPM	Coppia Max Max Torque Max Drehmoment	Reversibile lato mandrino/contromandrino Reversible sub/main spindle side Umkehrbare Spindel-seite/ Gegenspindel-seite	Lubr.interna Coolant through Innenkuehlung	Lubr. esterna Ext. coolant Aussenkuehlung	A	A1	B	D	L	CHIAVI NON INCLUSE Keys not included Schluessel nicht einbegriffen
DW 00870125	ER25	1:1	6000	50Nm	X	-	X	91.16	-	54.5	-	-	CHSTER25 OKU0650004 •
DW 00870225	ER25	1:1	6000	50Nm	X	P=70bar	X	91.16	-	65.5	-	-	CHSTER25 OKU0650004 •
DW 00870132	ER32	1:1	6000	50Nm	X	-	X	93.66	-	54.5	-	-	CHSTER32 OKU0650004 •
DW 00870232	ER32	1:1	6000	50Nm	X	P=70bar	X	93.66	-	65.5	-	-	CHSTER32 OKU0650004 •
DW 00870140	ER40	1:1	6000	50Nm	X	-	X	98.16	-	54.5	-	-	CHSTER40 OKU0650004 •
DW 00870240	ER40	1:1	6000	50Nm	X	P=70bar	X	98.16	-	65.5	-	-	CHSTER40 OKU0650004 •
DW 00870325	ERA25	1:1	6000	50Nm	X	-	X	65	-	54.5	-	CHUB27	CHTAER25ZC • OKU0650004 •
DW 00870425	ERA25	1:1	6000	50Nm	X	P=70bar	X	65	-	65.5	-	CHUB27	CHTAER25ZC • OKU0650004 •
DW 00870516	Ø16x17	1:1	6000	50Nm	X	-	X	-	67.5	54.5	16	17	CH_VTCROCE_M08 • OKU0650004 •
DW 00870522	Ø22x19	1:1	6000	50Nm	X	-	X	-	67.5	54.5	22	19	CH_VTCROCE_M10 • OKU0650004 •
DW 00870527	Ø27x21	1:1	6000	50Nm	X	-	X	-	70	54.5	27	21	CH_VTCROCE_M12 • OKU0650004 •

DOOSAN BMT 55

MOD: PUMA 230-240M/MS-280LM - PUMA 1500-2000-2500M/MS/Y/SY - LINX 300 M - PUMA 2100 12ST.
PUMA 2600 16ST. - TL2000-2500 (M) - PUMA GT2100-2600 M

MODULO MOTORIZZATO ASSIALE H=60mm

Axial driven tool H=60mm

Axial angetriebenes Werkzeug H=60mm

Subject to change without notice.

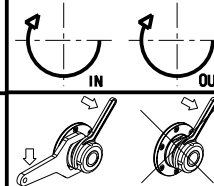

M.T. srl

Via Casino Albini 480
Tel. 0541/956034-957884
Fax 0541/956341
47842 S. GIOVANNI IN M. (RN)
e-mail: mtma@mtmarchetti.com
http://www.mtmarchetti.com

PRODUZIONE MODULI ROTANTI



PAGINA DW 0150-2-11

ATTENZIONE - ATTENTION - ACHTUNG

- VERIFICARE LE MISURE DI INGOMBRO PER POSSIBILE INTERFERENZA SU ALCUNI MODELLI DI MACCHINE
- Please check the overall sizes for possible interferences on some machine models
- Bitte überprüfen sie das ausmass um mögliche interfeenzen auf einigen maschinen modellen zu vermeiden

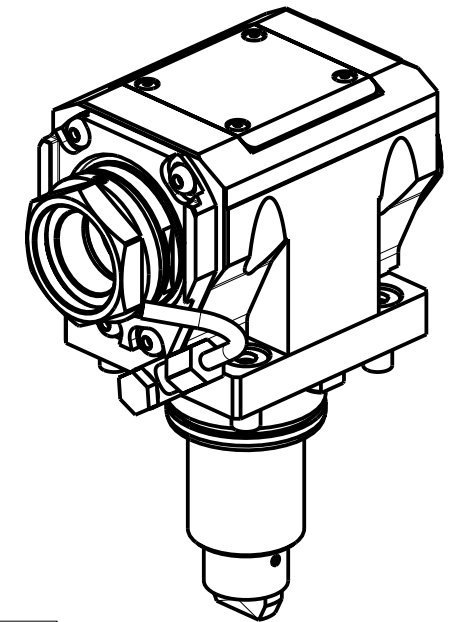
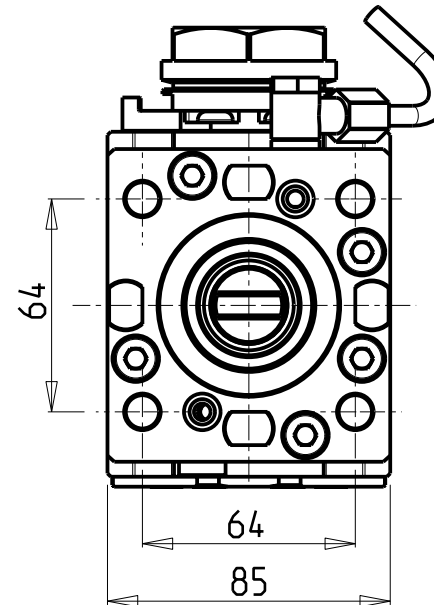
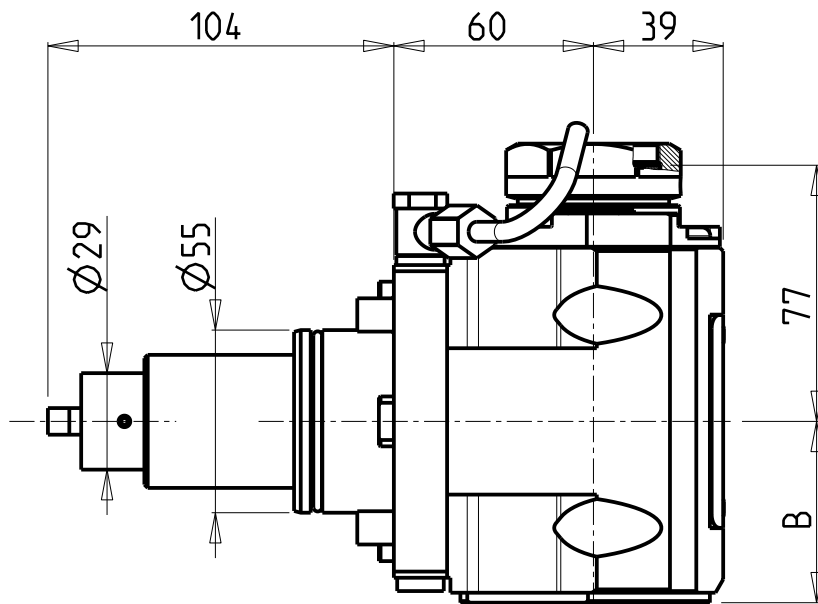

PER PORTAUTENSILI MODULARI MTSK-40 VEDI PAG. TBL300-1-40
 FOR MTSK-40 QUICK CHANGE TOOLHOLDERS CLAMPINGS SEE PAGE TBL300-1-40
 FUER MTSK-40 MODULARE WERKZEUGAUFNAHMEN SIEHE SEITE TBL300-1-40

Cod. MT	Mandrino Spindle Spindel	I	RPM	Coppia Max Max Torque Max Drehmoment	Reversibile lato mandrino/contromandrino Reversible sub/main spindle side Umkehrbare Spindel-seite/ Gegenspindel-seite	Lubr.interna Coolant through Innenkuehlung	Lubr.esterna Ext. coolant Aussenkuehlung	B	CHIAVI NON INCLUSE Keys not included Schlüssel nicht einbegriffen	
DW00770140	MTSK-40	1:1	6000	70Nm	X	-	X	54.5	CHUB46	OKU0650004 •
DW00770240	MTSK-40	1:1	6000	70Nm	X	P=70bar	X	65.5	CHUB46	OKU0650004 •

- Chiave inclusa
- Key included
- Schlüssel inbegriffen

DOOSAN BMT 55

MOD: PUMA 230-240M/MS-280LM - PUMA 1500-2000-2500M/MS/Y/SY - LINX 300 M - PUMA 2100 12ST.
 PUMA 2600 16ST. - TL2000-2500 (M) - PUMA GT2100-2600 M

MODULO MOTORIZZATO ASSIALE MTSK H=60mm

Axial MTSK driven tool H=60mm

Axial MTSK angetriebenes Werkzeug H=60mm

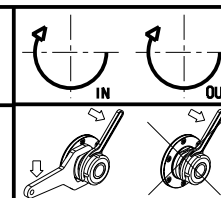

M.T. srl
 Via Casino Albini 480
 Tel. 0541/956034-957884
 Fax 0541/956341
 47842 S. GIOVANNI IN M. (RN)
 e-mail: mtma@mtmarchetti.com
 http://www.mtmarchetti.com

PRODUZIONE MODULI ROTANTI



PAGINA DW0150-2-11-K

Subject to change without notice.

04/2020

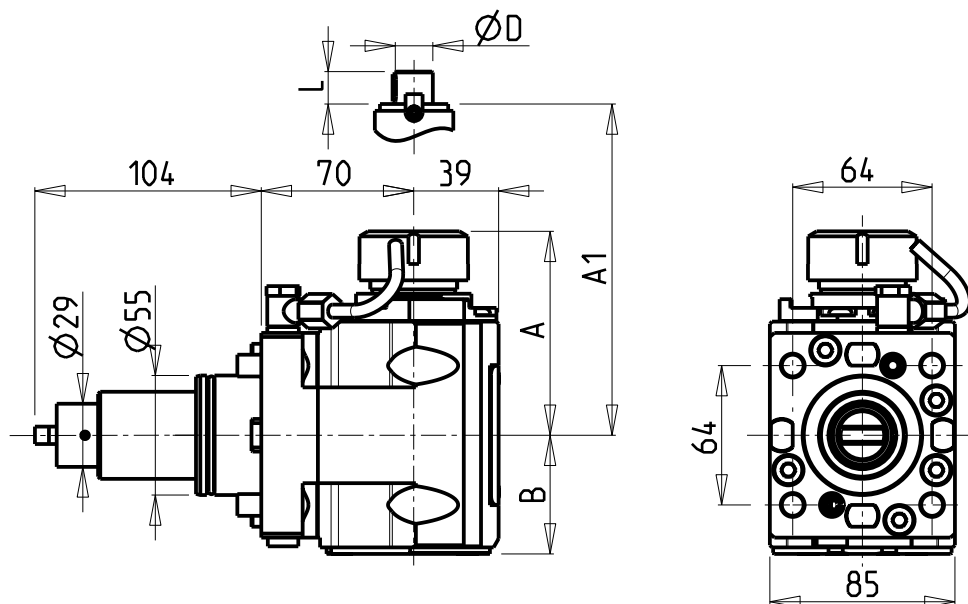

ATTENZIONE - ATTENTION - ACHTUNG

- VERIFICARE LE MISURE DI INGOMBRO PER POSSIBILE INTERFERENZA SU ALCUNI MODELLI DI MACCHINE
- Please check the overall sizes for possible interferences on some machine models
- Bitte überprüfen sie das ausmass um mögliche interferenzen auf einigen maschinen modellen zu vermeiden

- Chiave inclusa
- Key included
- Schlüssel inbegriffen

Cod. MT	Mandrino Spindle Spindel	I	RPM	Coppia Max Max Torque Max Drehmoment	Reversibile lato mandrino/contromandrino Reversible sub/main spindle side Umkehrbare Spindel-seite/ Gegenspindel-seite	Lubr.interna Coolant through Innenkuehlung	Lubr. esterna Ext. coolant Aussenkuehlung	A	A1	B	D	L	CHIAVI NON INCLUSE Keys not included Schlüssel nicht einbegriffen		
DW 00880125	ER25	1:1	6000	50Nm	X	-	X	91.16	-	54.5	-	-	-	CHSTER25	OKU0650004 *
DW 00880225	ER25	1:1	6000	50Nm	X	P=70bar	X	91.16	-	65.5	-	-	-	CHSTER25	OKU0650004 *
DW 00880132	ER32	1:1	6000	50Nm	X	-	X	93.66	-	54.5	-	-	-	CHSTER32	OKU0650004 *
DW 00880232	ER32	1:1	6000	50Nm	X	P=70bar	X	93.66	-	65.5	-	-	-	CHSTER32	OKU0650004 *
DW 00880140	ER40	1:1	6000	50Nm	X	-	X	98.16	-	54.5	-	-	-	CHSTER40	OKU0650004 *
DW 00880240	ER40	1:1	6000	50Nm	X	P=70bar	X	98.16	-	65.5	-	-	-	CHSTER40	OKU0650004 *
DW 00880325	ERA25	1:1	6000	50Nm	X	-	X	65	-	54.5	-	-	CHUB27	CHTAER25ZC *	OKU0650004 *
DW 00880425	ERA25	1:1	6000	50Nm	X	P=70bar	X	65	-	65.5	-	-	CHUB27	CHTAER25ZC *	OKU0650004 *
DW 00880516	∅16x17	1:1	6000	50Nm	X	-	X	-	67.5	54.5	16	17	-	CH_VTCROCE_M08 *	OKU0650004 *
DW 00880522	∅22x19	1:1	6000	50Nm	X	-	X	-	67.5	54.5	22	19	-	CH_VTCROCE_M10 *	OKU0650004 *
DW 00880527	∅27x21	1:1	6000	50Nm	X	-	X	-	70	54.5	27	21	-	CH_VTCROCE_M12 *	OKU0650004 *

DOOSAN BMT 55

MOD: PUMA 230-240M/MS-280LM - PUMA 1500-2000-2500M/MS/Y/SY - LINX 300 M - PUMA 2100 12ST.
PUMA 2600 16ST. - TL2000-2500 (M) - PUMA GT2100-2600 M - PUMA H250TM - PUMA QL200HM

MODULO MOTORIZZATO ASSIALE H=70mm

Axial driven tool H=70mm

Axial angetriebenes Werkzeug H=70mm

Subject to change without notice.

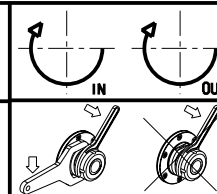

M.T. srl

Via Casino Albini 480
Tel. 0541/956034-957884
Fax 0541/956341
47842 S. GIOVANNI IN M. (RN)
e-mail: mtma@mtmarchetti.com
http://www.mtmarchetti.com

PRODUZIONE MODULI ROTANTI



PAGINA DW 0150-2-21

ATTENZIONE - ATTENTION - ACHTUNG

- VERIFICARE LE MISURE DI INGOMBRO PER POSSIBILE INTERFERENZA SU ALCUNI MODELLI DI MACCHINE
- Please check the overall sizes for possible interferences on some machine models
- Bitte überprüfen sie das ausmass um mögliche interfeenzen auf einigen maschinen modellen zu vermeiden

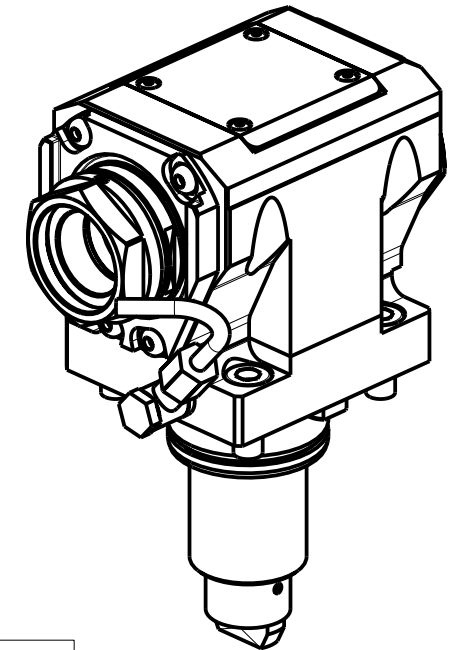
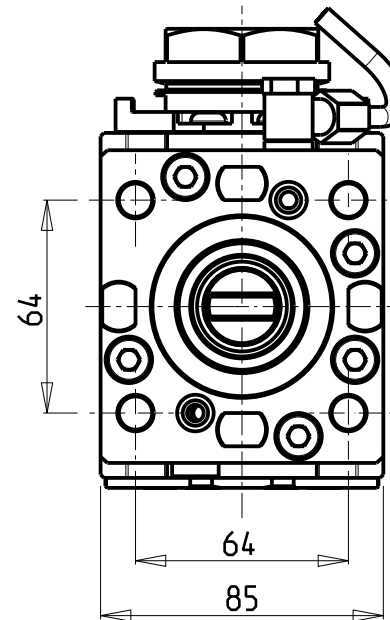
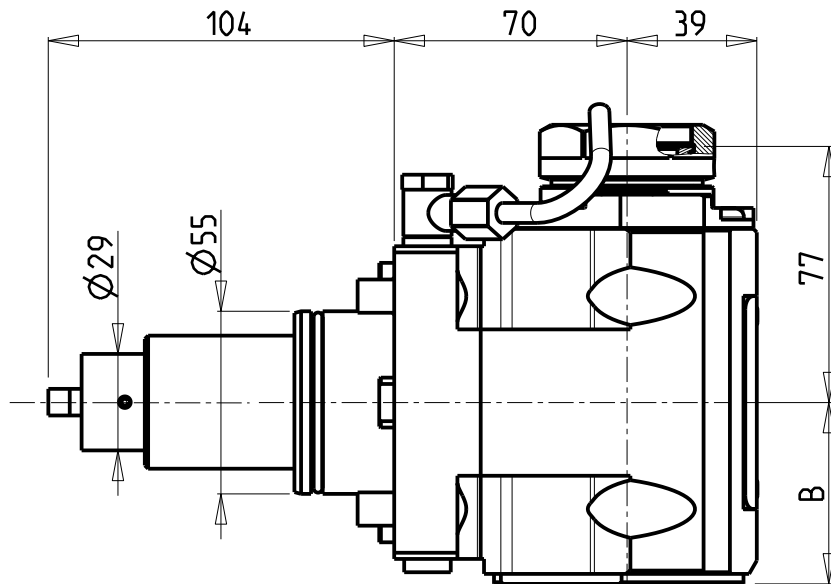

PER PORTAUTENSILI MODULARI MTSK-40 VEDI PAG. TBL300-1-40
 FOR MTSK-40 QUIK CHANGE TOOLHOLDERS CLAMPINGS SEE PAGE TBL300-1-40
 FUER MTSK-40 MODULARE WERKZEUGAUFNAHMEN SIEHE SEITE TBL300-1-40

Cod. MT	Mandrino Spindle Spindel	I	RPM	Coppia Max Max Torque Max Drehmoment	Reversibile lato mandrino/controlmandrino Reversible sub/main spindle side Umkehrbare Spindel-seite/Gegenspindel-seite	Lubr.interna Coolant through Innenkuehlung	Lubr.esterna Ext. coolant Aussenkuehlung	B	CHIAVI NON INCLUDE Keys not included Schluessel nicht einbegriffen	
DW 00780140	MTSK-40	1:1	6000	70Nm	X	-	X	54.5	CHUB46	OKU0650004 •
DW 00780240	MTSK-40	1:1	6000	70Nm	X	P=70bar	X	65.5	CHUB46	OKU0650004 •

- Chiave inclusa
- Key included
- Schluessel inbegriffen

DOOSAN BMT 55
 MOD: PUMA 230-240M/MS-280LM - PUMA 1500-2000-2500M/MS/Y/SY - LINX 300 M - PUMA 2100 12ST.
 PUMA 2600 16ST. - TL2000-2500 (M) - PUMA GT2100-2600 M - PUMA H250TM - PUMA QL200HM

MODULO MOTORIZZATO ASSIALE MTSK H=70mm
 Axial MTSK driven tool H=70mm
 Axial MTSK angetriebenes Werkzeug H=70mm

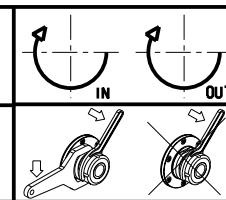

M.T. srl
 Via Casino Albini 480
 Tel. 0541/956034-957884
 Fax 0541/956341
 47842 S. GIOVANNI IN M. (RN)
 e-mail: mtma@tmarchetti.com
 http://www.tmmarchetti.com

PRODUZIONE MODULI ROTANTI



PAGINA DW0150-2-21-K

Subject to change without notice.

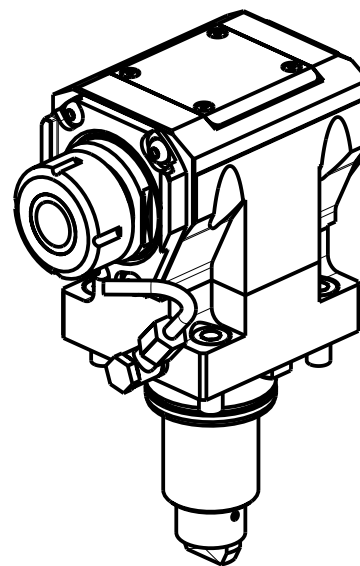
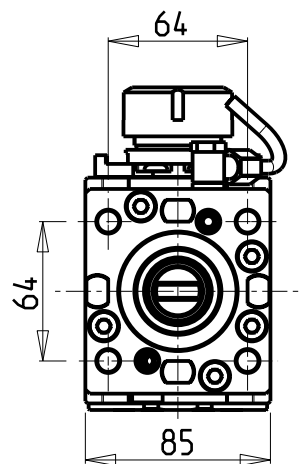
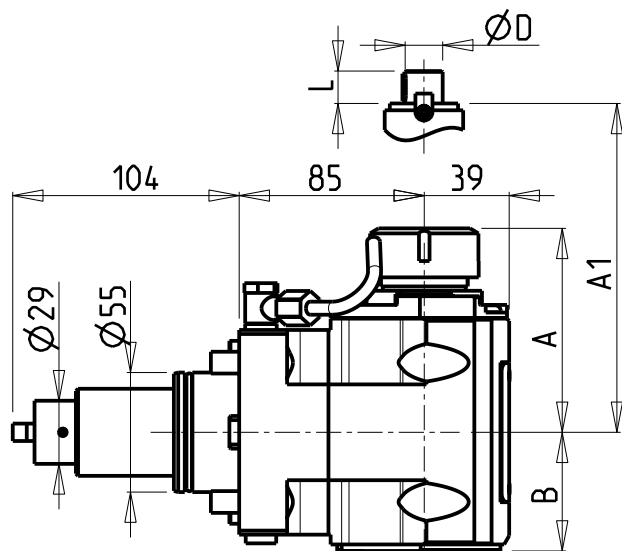

ATTENZIONE - ATTENTION - ACHTUNG

- VERIFICARE LE MISURE DI INGOMBRO PER POSSIBILE INTERFERENZA SU ALCUNI MODELLI DI MACCHINE
- Please check the overall sizes for possible interferences on some machine models
- Bitte überprüfen sie das ausmass um mögliche interferenzen auf einigen maschinen modellen zu vermeiden

- Chiave inclusa
- Key included
- Schlüssel inbegriffen

Cod. MT	Mandrino Spindle Spindel	I	RPM	Coppia Max Max Torque Max Drehmoment	Reversibile lato mandrino/contromandrino Reversible sub/main spindle side Umkehrbare Spindel-seite/ Gegenspindel-seite	Lubr.interna Coolant through Innenkuehlung	Lubr. esterna Ext. coolant Aussenkuehlung	A	A1	B	D	L	CHIAVI NON INCLUSE Keys not included Schlüssel nicht einbegriffen		
DW 00890125	ER25	1:1	6000	50Nm	X	-	X	91.16	-	54.5	-	-	-	CHSTER25	OKU0650004 •
DW 00890225	ER25	1:1	6000	50Nm	X	P=70bar	X	91.16	-	65.5	-	-	-	CHSTER25	OKU0650004 •
DW 00890132	ER32	1:1	6000	50Nm	X	-	X	93.66	-	54.5	-	-	-	CHSTER32	OKU0650004 •
DW 00890232	ER32	1:1	6000	50Nm	X	P=70bar	X	93.66	-	65.5	-	-	-	CHSTER32	OKU0650004 •
DW 00890140	ER40	1:1	6000	50Nm	X	-	X	98.16	-	54.5	-	-	-	CHSTER40	OKU0650004 •
DW 00890240	ER40	1:1	6000	50Nm	X	P=70bar	X	98.16	-	65.5	-	-	-	CHSTER40	OKU0650004 •
DW 00890325	ERA25	1:1	6000	50Nm	X	-	X	65	-	54.5	-	-	CHUB27	CHTAER25ZC •	OKU0650004 •
DW 00890425	ERA25	1:1	6000	50Nm	X	P=70bar	X	65	-	65.5	-	-	CHUB27	CHTAER25ZC •	OKU0650004 •
DW 00890516	Ø16x17	1:1	6000	50Nm	X	-	X	-	67.5	54.5	16	17	-	CH_VTCROCE_M08 •	OKU0650004 •
DW 00890522	Ø22x19	1:1	6000	50Nm	X	-	X	-	67.5	54.5	22	19	-	CH_VTCROCE_M10 •	OKU0650004 •
DW 00890527	Ø27x21	1:1	6000	50Nm	X	-	X	-	70	54.5	27	21	-	CH_VTCROCE_M12 •	OKU0650004 •

DOOSAN BMT 55

MOD: PUMA 230-240M/MS-280LM - PUMA 1500-2000-2500M/MS/Y/SY - LINX 300 M - PUMA 2100 12ST. - PUMA H250TM
PUMA TT1500-1800-2100MS/SY/SYY - PUMA TL2000-2500 (M) - MX1600/2100ST 12ST. - PUMA GT2100-2600 M - PUMA QL200HM

MODULO MOTORIZZATO ASSIALE H=85mm

Axial driven tool H=85mm

Axial angetriebenes Werkzeug H=85mm

Subject to change without notice.

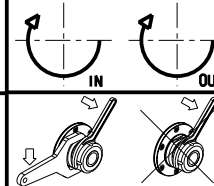

M.T. srl

Via Casino Albini 480
Tel. 0541/956034-957884
Fax 0541/956341
47842 S. GIOVANNI IN M. (RN)
e-mail: mtma@mtmarchetti.com
http://www.mtmarchetti.com

PRODUZIONE MODULI ROTANTI



PAGINA DW 0150-2-31

ATTENZIONE - ATTENTION - ACHTUNG

- VERIFICARE LE MISURE DI INGOMBRO PER POSSIBILE INTERFERENZA SU ALCUNI MODELLI DI MACCHINE
- Please check the overall sizes for possible interferences on some machine models
- Bitte überprüfen sie das ausmass um mögliche interfeenzen auf einigen maschinen modellen zu vermeiden

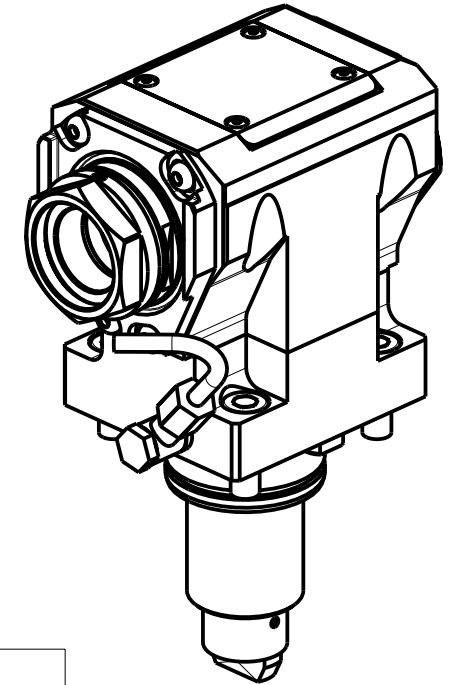
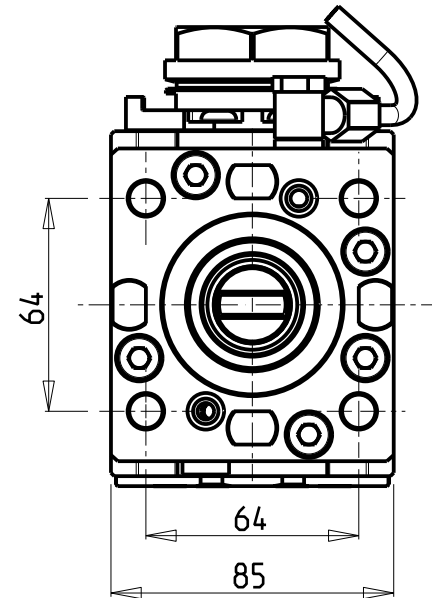
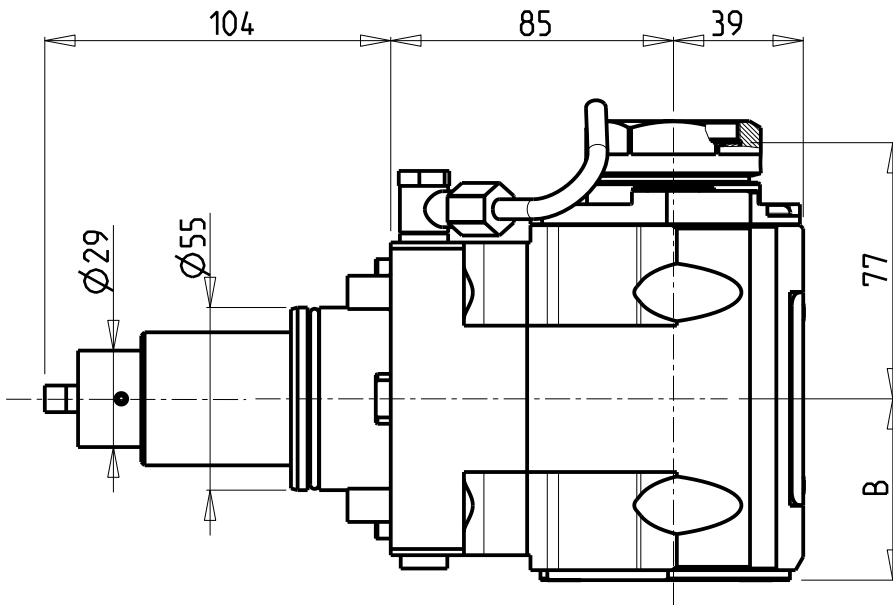

- Chiave inclusa
- Key included
- Schlüssel inbegriffen

PER PORTAUTENSILI MODULARI MTSK-40 VEDI PAG. TBL300-1-40
 FOR MTSK-40 QUIK CHANGE TOOLHOLDERS CLAMPINGS SEE PAGE TBL300-1-40
 FUER MTSK-40 MODULARE WERKZEUGAUFNAHMEN SIEHE SEITE TBL300-1-40

Cod. MT	Mandrino Spindle Spindel	I	RPM	Coppia Max Max Torque Max Drehmoment	Reversibile lato mandrino/contromandrino Reversible sub/main spindle side Umkehrbare Spindel-seite/ Gegenspindel-seite	Lubr.interna Coolant through Innenkuehlung	Lubr.esterna Ext. coolant Aussenkuehlung	B	CHIAVI NON INCLUDE Keys not included Schlüssel nicht einbegriffen	
DW 00790140	MTSK-40	1:1	6000	70Nm	X	-	X	54.5	CHUB46	OKU0650004 •
DW 00790240	MTSK-40	1:1	6000	70Nm	X	P=70bar	X	65.5	CHUB46	OKU0650004 •

DOOSAN BMT 55

MOD: PUMA 230-240M/MS-280LM - PUMA 1500-2000-2500M/MS/Y/SY - LINX 300 M - PUMA 2100 12ST. - PUMA H250TM
 PUMA TT1500-1800-2100MS/SY/SYY - PUMA TL2000-2500 (M) - MX1600/2100ST 12ST. - PUMA GT2100-2600 M - PUMA QL200HM

MODULO MOTORIZZATO ASSIALE MTSK H=85mm
 Axial MTSK driven tool H=85mm
 Axial MTSK angetriebenes Werkzeug H=85mm

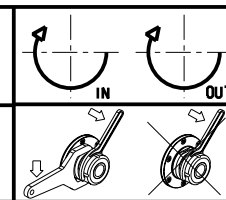

M.T. srl
 Via Casino Albini 480
 Tel. 0541/956034-957884
 Fax 0541/956341
 47842 S. GIOVANNI IN M. (RN)
 e-mail: mtma@tmarchetti.com
 http://www.mtmarchetti.com

PRODUZIONE MODULI ROTANTI



PAGINA DW0150-2-31-K

Subject to change without notice.

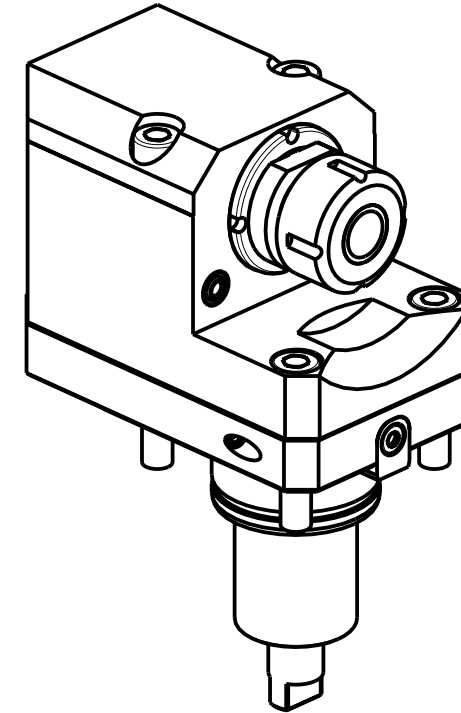
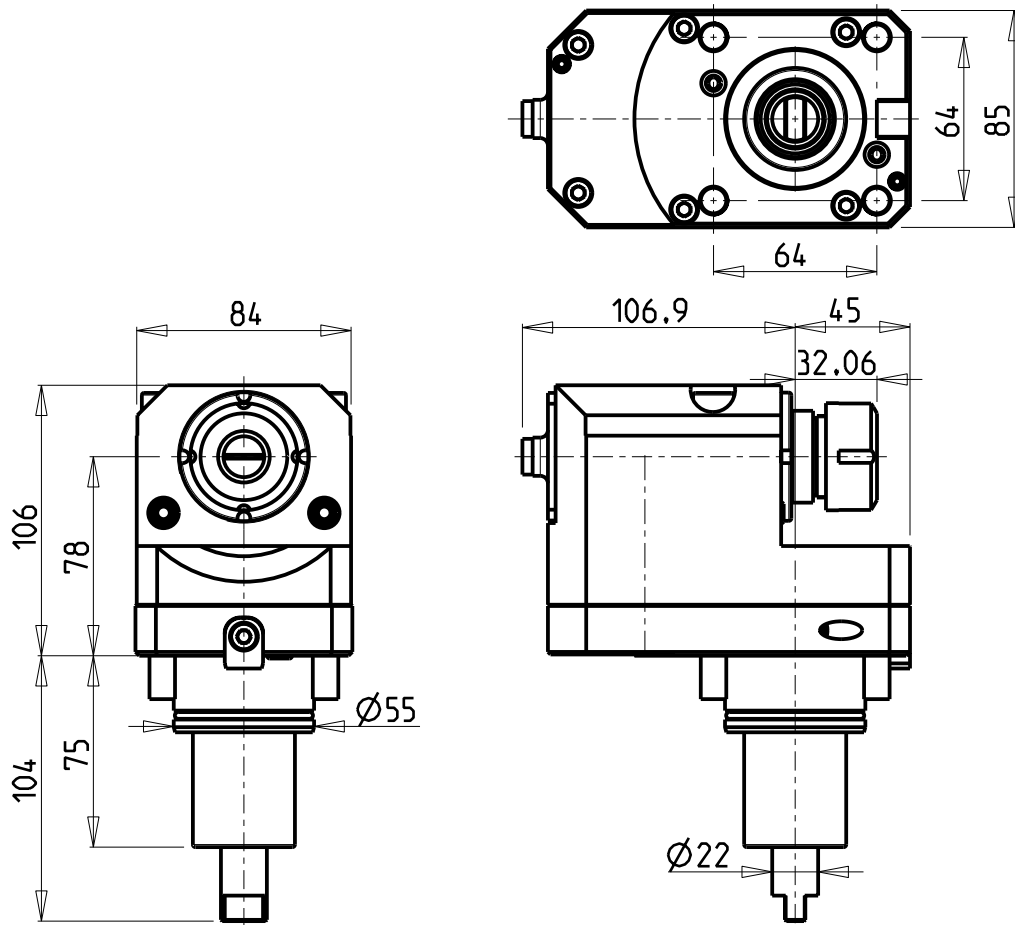

Cod. MT	Mandrino Spindle Spindel	I	RPM	Coppia Max Max Torque Max Drehmoment	Reversibile lato mandrino/contromandrino Reversible sub/main spindle side Umkehrbare Spindel-seite/ Gegenspindel-seite	Lubrificazione est. Ext. coolant Aussenkuehlung	CHIAVI NON INCLUSE Keys not included Schlüssel nicht einbegriffen	
0630025	ER25	1:1	6000	50Nm	X	X	CHSTER25	CHUB36

DOOSAN BMT 55

MOD: PUMA 230-240M/MS-280LM - PUMA 1500-2000-2500M/MS/Y/SY - LINX 300 M - PUMA 2100 12ST.
TL2000-2500 (M) - PUMA H250TM - PUMA QL200HM

MODULO MOTORIZZATO ASSIALE ARRETRATO

Axial rear-set driven tool

Axial angetriebenes Werkzeug zurueckversetzt

Subject to change without notice.

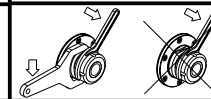

M.T. srl

Via Casino Albini 480
Tel. 0541/956034-957884
Fax 0541/956341
47842 S. GIOVANNI IN M. (RN)
e-mail: mtma@mtmarchetti.com
http://www.mtmarchetti.com

PRODUZIONE MODULI ROTANTI



PAGINA DW0180-2-10

ATTENZIONE - ATTENTION - ACHTUNG

- VERIFICARE LE MISURE DI INGOMBRO PER POSSIBILE INTERFERENZA SU ALCUNI MODELLI DI MACCHINE
- Please check the overall sizes for possible interferences on some machine models
- Bitte überprüfen sie das ausmass um mögliche interferenzen auf einigen maschinen modellen zu vermeiden

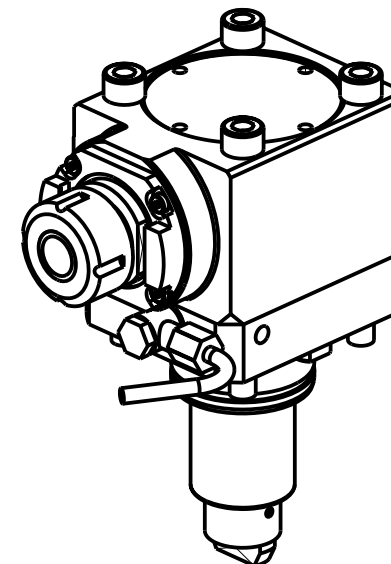
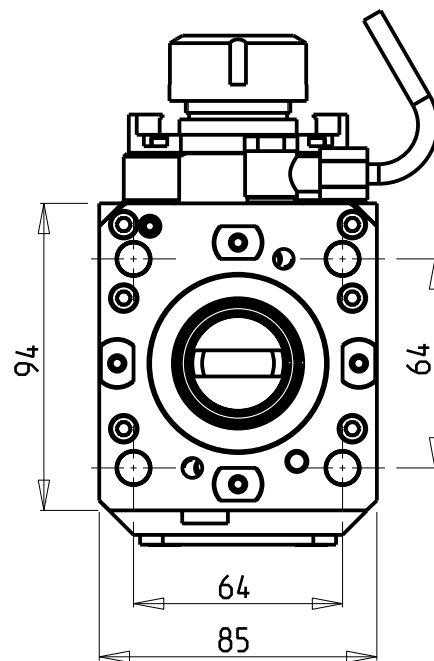
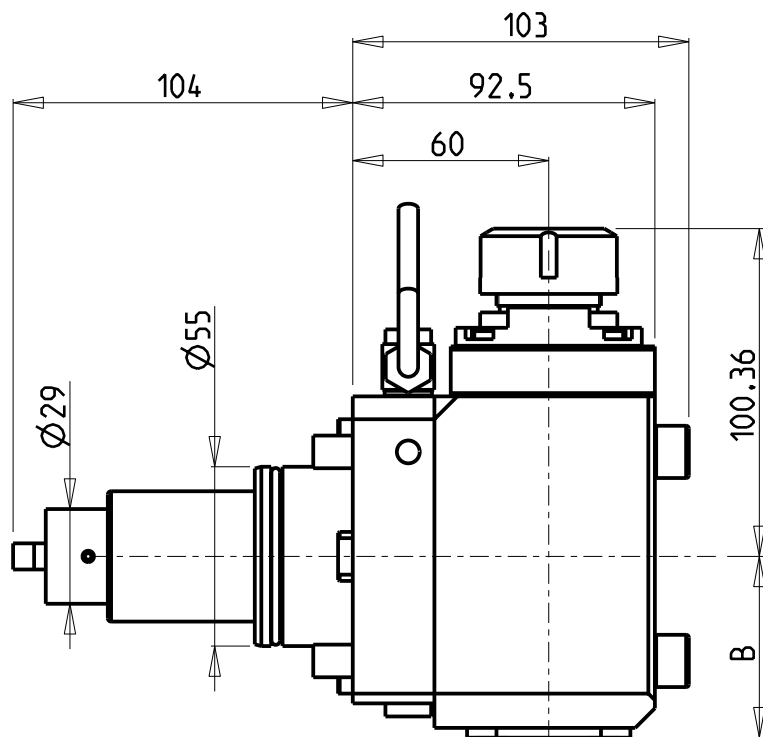

Cod. MT	Mandrino Spindel Spindel	i	RPM	Coppia Max Max Torque Max Drehmoment	Reversibile lato mandrino/contromandrino Reversible sub/main spindle side Umkehrbare Spindelseite/ Gegenspindelseite	Lubrificazione int. Coolant through Innenkuehlung	Lubrificazione est. Ext. coolant Aussenkuehlung	B	CHIAVI NON INCLUSE Keys not included Schluessel nicht einbegriffen	
0891225	ER25	1:2	12000	30Nm	X	-	X	55.5	CHSTER25	SAU0070027 ■
0891325	ER25	1:2	12000	30Nm	X	P=70bar	X	66.5	CHSTER25	SAU0070027 ■

- Chiave inclusa
- Key included
- Schluessel inbegriffen

DOOSAN BMT 55

MOD: PUMA 230-240M/MS-280LM - PUMA 1500-2000-2500M/MS/Y/SY - LINX 300 M - PUMA 2100 12ST. - PUMA 2600 16ST.
PUMA TL2000-2500 (M) - PUMA GT2100-2600 M

MODULO MOTORIZZATO ASSIALE MOLTIPLICATO i=1:2 H=60mm

Axial geared-up i=1:2 driven tool H=60mm

Axial angetriebenes Werkzeug uebersetzt i=1:2 H=60mm

Subject to change without notice.

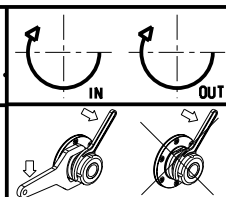

M.T. srl
Via Casino Albini 480
Tel. 0541/956034-957884
Fax 0541/956341
47842 S. GIOVANNI IN M. (RN)
e-mail: mtma@mtmarchetti.com
http://www.mtmarchetti.com

PRODUZIONE MODULI ROTANTI



PAGINA DW0200-2-10

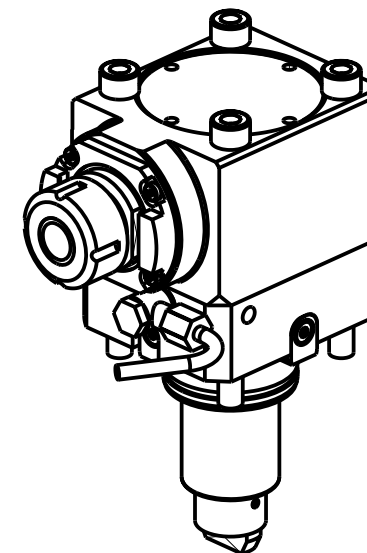
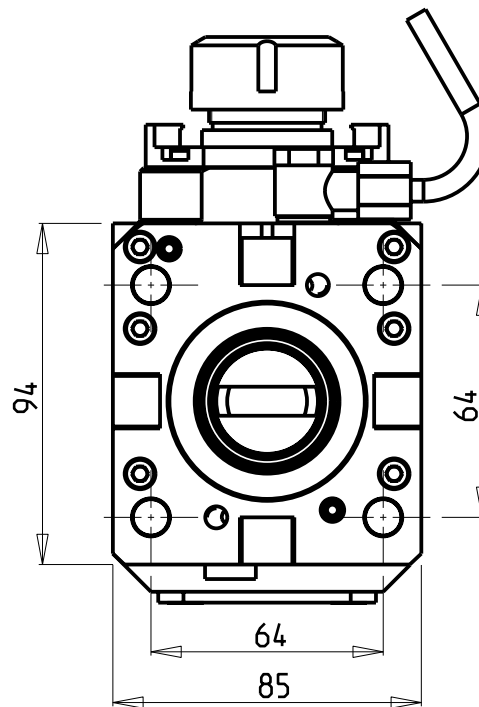
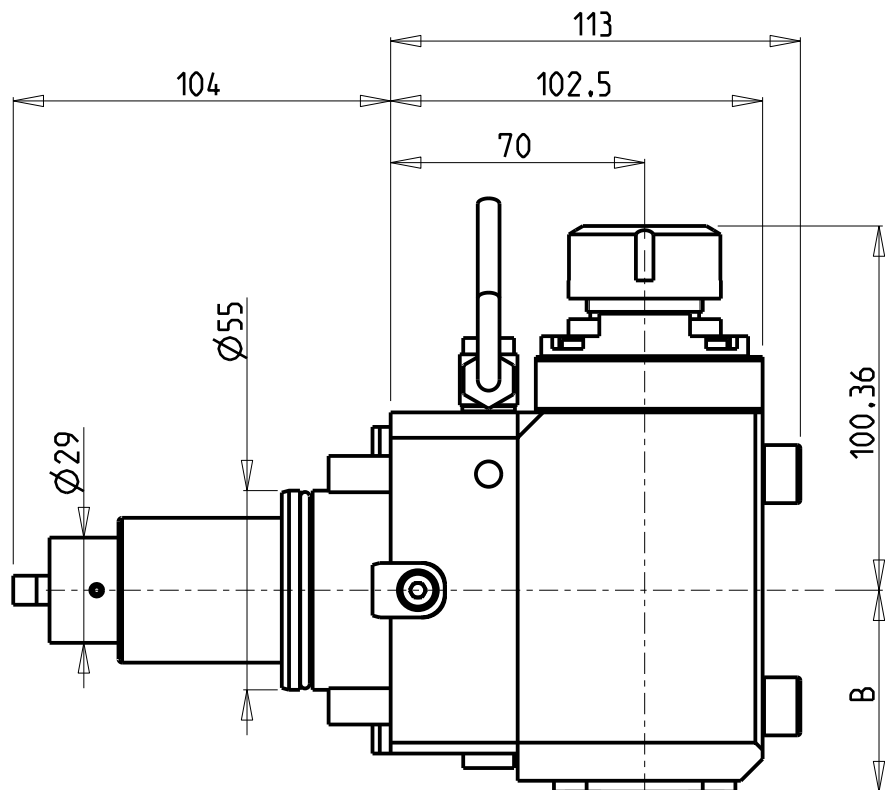

ATTENZIONE - ATTENTION - ACHTUNG

- VERIFICARE LE MISURE DI INGOMBRO PER POSSIBILE INTERFERENZA SU ALCUNI MODELLI DI MACCHINE
- Please check the overall sizes for possible interferences on some machine models
- Bitte überprüfen sie das ausmass um mögliche interferenzen auf einigen maschinen modellen zu vermeiden

• Chiave inclusa

• Key included

• Schlüssel inbegriffen

Cod. MT	Mandrino Spindle Spindel	I	RPM	Coppia Max Max Torque Max Drehmoment	Reversibile lato mandrino/contromandrino Reversible sub/main spindle side Umkehrbare Spindel-seite/ Gegenspindel-seite	Lubrificazione int. Coolant through Innenkuehlung	Lubrificazione est. Ext. coolant Aussenkuehlung	B	CHIAVI NON INCLUSE Keys not included Schlüssel nicht einbegriffen	
0893625	ER25	1:2	12000	30Nm	X	-	X	55.5	CHSTER25	SAU0070027 ■
0893725	ER25	1:2	12000	30Nm	X	P=70bar	X	66.5	CHSTER25	SAU0070027 ■

DOOSAN BMT 55

MOD: PUMA 230-240M/MS-280LM - PUMA 1500-2000-2500M/MS/Y/SY - LINX 300 M - PUMA 2100 12ST. - PUMA 2600 16ST.
PUMA TL2000-2500 (M) - PUMA GT2100-2600 M - PUMA H250TM - PUMA QL200HM

MODULO MOTORIZZATO ASSIALE MOLTIPLICATO I=1:2 H=70mm

Axial geared-up I=1:2 driven tool H=70mm

Axial angetriebenes Werkzeug uebersetzt I=1:2 H=70mm

Subject to change without notice.

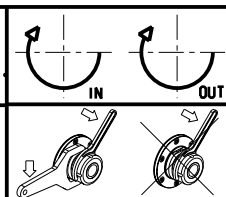

M.T. srl

Via Casino Albini 480
Tel. 0541/956034-957884
Fax 0541/956341

47842 S. GIOVANNI IN M. (RN)
e-mail: mtma@mtmarchetti.com
http://www.mtmarchetti.com

PRODUZIONE MODULI ROTANTI



PAGINA DW 0200-2-20

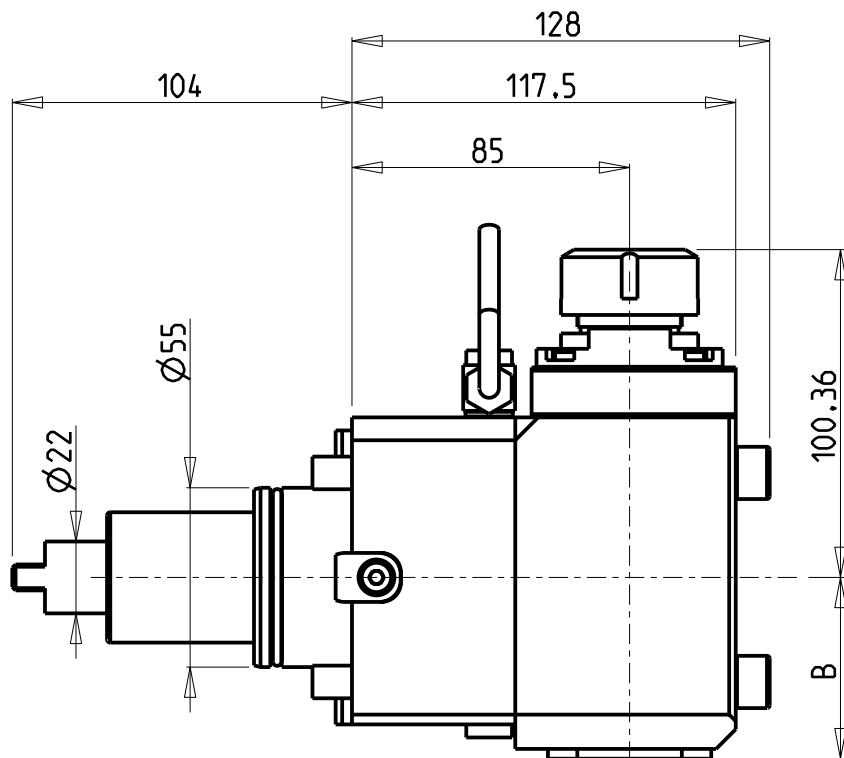

ATTENZIONE - ATTENTION - ACHTUNG

- VERIFICARE LE MISURE DI INGOMBRO PER POSSIBILE INTERFERENZA SU ALCUNI MODELLI DI MACCHINE
- Please check the overall sizes for possible interferences on some machine models
- Bitte überprüfen sie das ausmass um mögliche interferenzen auf einigen maschinen modellen zu vermeiden

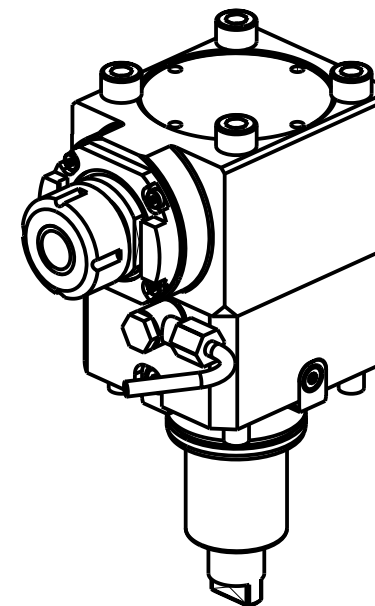
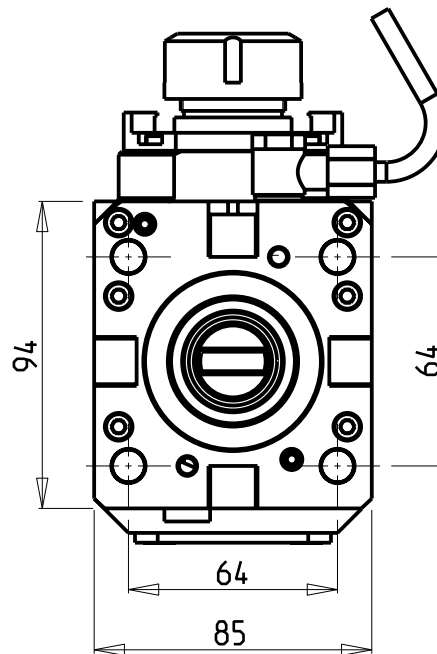

• Chiave inclusa

• Key included

• Schluessel inbegriffen

Cod. MT	Mandrino Spindle Spindel	I	RPM	Coppia Max Max Torque Max Drehmoment	Reversibile lato mandrino/contromandrino Reversible sub/main spindle side Umkehrbare Spindel-seite/ Gegenspindel-seite	Lubrificazione int. Coolant through Innenkuehlung	Lubrificazione est. Ext. coolant Aussenkuehlung	B	CHIAVI NON INCLUSE Keys not included Schluessel nicht einbegriffen	
0892425	ER25	1:2	12000	30Nm	X	-	X	55.5	CHSTER25	SAU0070027 *
0892525	ER25	1:2	12000	30Nm	X	P=70bar	X	66.5	CHSTER25	SAU0070027 *

DOOSAN BMT 55

MOD: PUMA 230-240M/MS-280LM - PUMA 1500-2000-2500M/MS/Y/SY - LINX 300 M - PUMA 2100 12ST. - PUMA H250TM
PUMA TT1500-1800-2100MS/SY/SYY - PUMA TL2000-2500 (M) - MX1600/2100ST 12ST. - PUMA GT2100-2600 M - PUMA QL200HM

MODULO MOTORIZZATO ASSIALE MOLTIPLICATO I=1:2 H=85mm

Axial geared-up I=1:2 driven tool H=85mm

Axial angetriebenes Werkzeug uebersetzt I=1:2 H=85mm

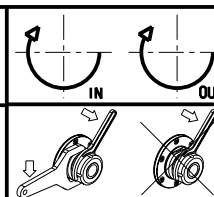

M.T. srl

Via Casino Albini 480
Tel. 0541/956034-957884
Fax 0541/956341
47842 S. GIOVANNI IN M. (RN)
e-mail: mtma@mtmarchetti.com
http://www.mtmarchetti.com

PRODUZIONE MODULI ROTANTI



PAGINA DW0200-2-30

Subject to change without notice.

04/2020

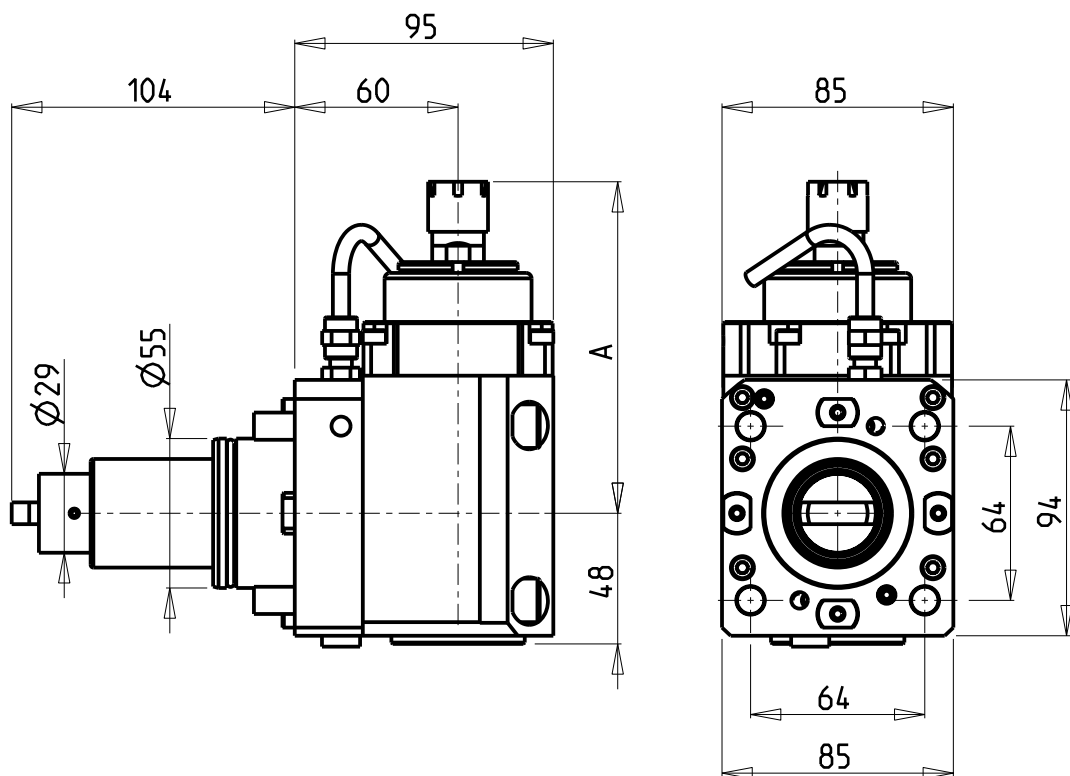

ATTENZIONE - ATTENTION - ACHTUNG

- VERIFICARE LE MISURE DI INGOMBRO PER POSSIBILE INTERFERENZA SU ALCUNI MODELLI DI MACCHINE
- Please check the overall sizes for possible interferences on some machine models
- Bitte überprüfen sie das ausmass um mögliche interferenzen auf einigen maschinen modellen zu vermeiden

ATTENZIONE - ATTENTION - ACHTUNG

- PRIMA DI UTILIZZARE IL MOTORIZZATO CONSULTARE LE ISTRUZIONI ALLEGATE!
- BEFORE USING THE DRIVEN TOOL, PLEASE CHECK THE ENCLOSED INSTRUCTION SHEET!
- VOR DER BENUTZUNG DES ANGETRIEBENEN WERKZEUGES, DIE BEILIEGENDEN INSTRUKTIONEN DURCHLESEN!

ATTENZIONE - ATTENTION - ACHTUNG

- Per lo smontaggio degli utensili utilizzare sempre la chiave di contrasto come indicato nel manuale d'uso.
- For disassembly of the tools use always the contrast key as mentioned in the user instructions.
- Fuer das Abmontieren der Werkzeuge immer den Gegenschlüssel benutzen wie in der Bedienungsanleitung erwaeht.

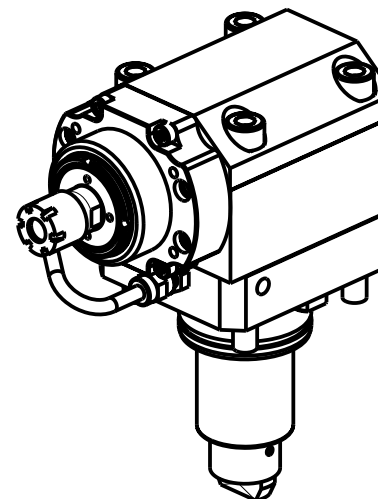

Cod. MT	Mandrino Spindle Spindel	I	RPM MAX	Coppia Max Max Torque Max Drehmoment	Reversibile lato mandrino/contromandrino Reversible sub/main spindle side Umkehrbare Spindel-seite/ Gegenspindel-seite	Lubrificazione int. Coolant through Innenkuehlung	Lubrificazione est. Ext. coolant Aussenkuehlung	A	CHIAVI INCLUSE Keys included Schluessel einbegriffen	
DW 00190116	ER16	1:5.625	22500	6Nm	X	-	X	121.8	CHMNER16	CHUB17
DW 00190111	ER11	1:5.625	22500	6Nm	X	P=30bar	-	134	CHMNER11	CHUB11

DOOSAN BMT 55

MOD: PUMA 230-240M/MS-280LM - PUMA 1500-2000-2500M/MS/Y/SY - LINX 300 M - PUMA 2100 12ST. - PUMA 2600 16ST.
PUMA TL2000-2500 (M) - PUMA GT2100-2600 M

MODULO MOTORIZZATO ASSIALE MOLTIPLICATO I=1:5.625 H=60mm

Axial geared-up I=1:5.625 driven tool H=60mm

Axial angetriebenes Werkzeug uebersetzt I=1:5.625 H=60mm

Subject to change without notice.

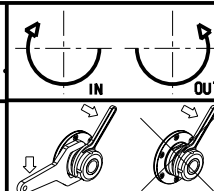

M.T. srl

Via Casino Albini 480
Tel. 0541/956034-957884
Fax 0541/956341
47842 S. GIOVANNI, IN M. (RN)
e-mail: mtma@mtmarchetti.com
http://www.mtmarchetti.com

PRODUZIONE MODULI ROTANTI



PAGINA DW 0210-2-10

ATTENZIONE - ATTENTION - ACHTUNG

- VERIFICARE LE MISURE DI INGOMBRO PER POSSIBILE INTERFERENZA SU ALCUNI MODELLI DI MACCHINE
- Please check the overall sizes for possible interferences on some machine models
- Bitte überprüfen sie das ausmass um mögliche interferenzen auf einigen maschinen modellen zu vermeiden

ATTENZIONE - ATTENTION - ACHTUNG

- PRIMA DI UTILIZZARE IL MOTORIZZATO CONSULTARE LE ISTRUZIONI ALLEGATE!
- BEFORE USING THE DRIVEN TOOL, PLEASE CHECK THE ENCLOSED INSTRUCTION SHEET!
- VOR DER BENUTZUNG DES ANGETRIEBENEN WERKZEUGES, DIE BEILIEGENDEN INSTRUKTIONEN DURCHLESEN!

ATTENZIONE - ATTENTION - ACHTUNG

- Per lo smontaggio degli utensili utilizzare sempre la chiave di contrasto come indicato nel manuale d'uso.
- For disassembly of the tools use always the contrast key as mentioned in the user instructions.
- Fuer das Abmontieren der Werkzeuge immer den Gegenschluesel benutzen wie in der Bedienungsanleitung erwaeht.

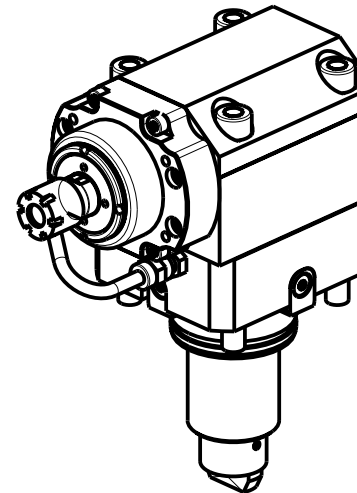
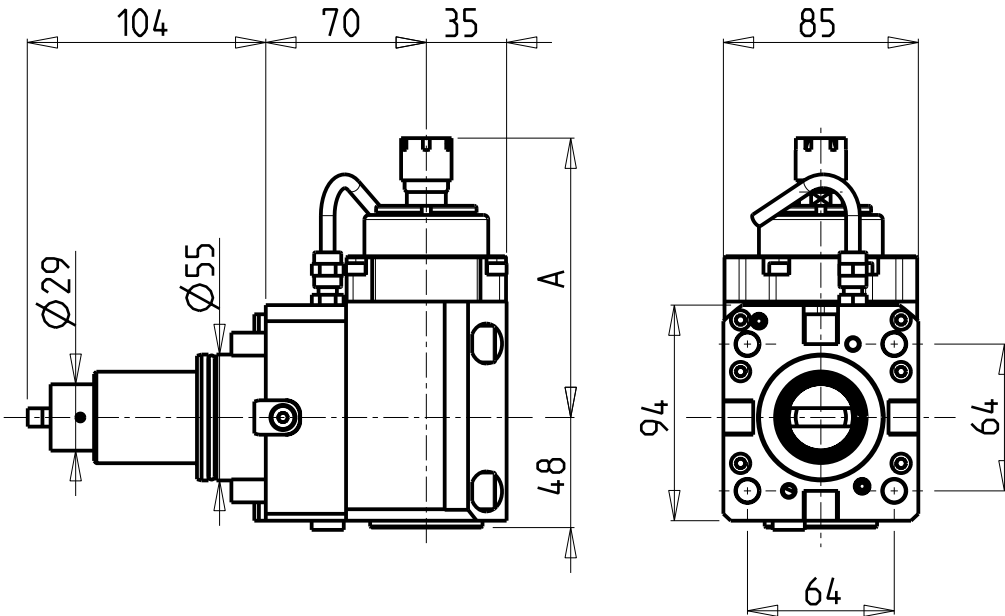

Cod. MT	Mandrino Spindle Spindel	I	RPM MAX	Coppia Max Max Torque Max Drehmoment	Reversibile lato mandrino/contromandrino Reversible sub/main spindle side Umkehrbare Spindel-seite/ Gegenspindel-seite	Lubrificazione int. Coolant through Innenkuehlung	Lubrificazione est. Ext. coolant Aussenkuehlung	A	CHIAVI INCLUSE Keys included Schluesel einbegriffen	
DW 00190316	ER16	1:5.625	22500	6Nm	X	-	X	121.8	CHMNER16	CHUB17
DW 00190311	ER11	1:5.625	22500	6Nm	X	P=30bar	-	134	CHMNER11	CHUB11

DOOSAN BMT 55

MOD: PUMA 230-240M/MS-280LM - PUMA 1500-2000-2500M/MS/Y/SY - LINX 300 M - PUMA 2100 12ST. - PUMA 2600 16ST.
 PUMA TL2000-2500 (M) - PUMA GT2100-2600 M - PUMA H250TM - PUMA QL200HM

MODULO MOTORIZZATO ASSIALE MOLTIPLICATO I=1:5.625 H=70mm

Axial geared-up I=1:5.625 driven tool H=70mm

Axial angetriebenes Werkzeug uebersetzt I=1:5.625 H=70mm

Subject to change without notice.

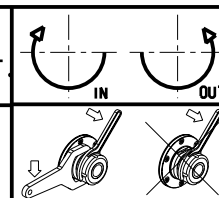

M.T. srl

Via Casino Albini 480
 Tel. 0541/956034-957884
 Fax 0541/956341
 47842 S. GIOVANNI, IN M. (RN)
 e-mail: mtma@mtmarchetti.com
 http://www.mtmarchetti.com

PRODUZIONE MODULI ROTANTI



PAGINA DW 0210-2-20

ATTENZIONE - ATTENTION - ACHTUNG

- VERIFICARE LE MISURE DI INGOMBRO PER POSSIBILE INTERFERENZA SU ALCUNI MODELLI DI MACCHINE
- Please check the overall sizes for possible interferences on some machine models
- Bitte überprüfen sie das ausmass um mögliche interferenzen auf einigen maschinen modellen zu vermeiden

ATTENZIONE - ATTENTION - ACHTUNG

- PRIMA DI UTILIZZARE IL MOTORIZZATO CONSULTARE LE ISTRUZIONI ALLEGATE!
- BEFORE USING THE DRIVEN TOOL, PLEASE CHECK THE ENCLOSED INSTRUCTION SHEET!
- VOR DER BENUTZUNG DES ANGETRIEBENEN WERKZEUGES, DIE BEILIEGENDEN INSTRUKTIONEN DURCHLESEN!

ATTENZIONE - ATTENTION - ACHTUNG

- Per lo smontaggio degli utensili utilizzare sempre la chiave di contrasto come indicato nel manuale d'uso.
- For disassembly of the tools use always the contrast key as mentioned in the user instructions.
- Fuer das Abmontieren der Werkzeuge immer den Gegenschluesel benutzen wie in der Bedienungsanleitung erwaeht.

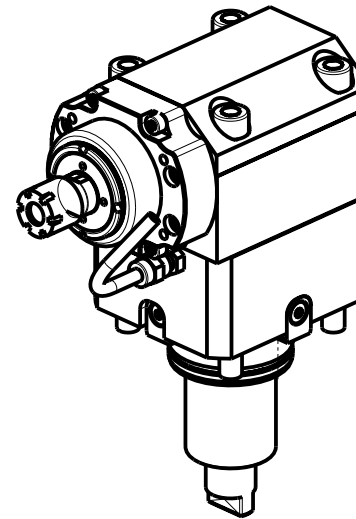
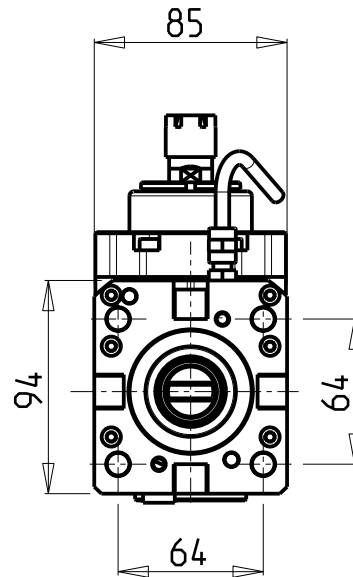
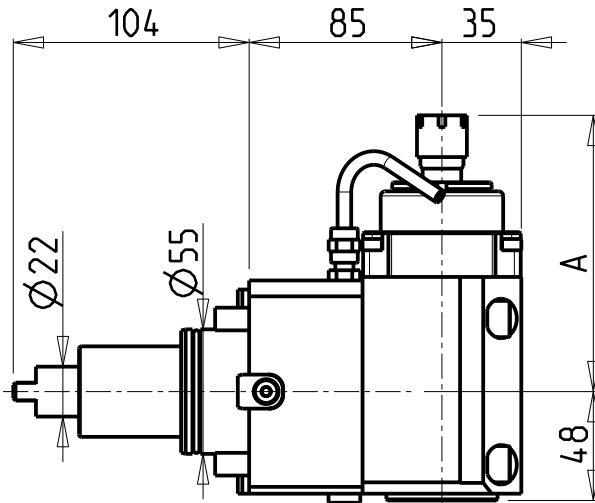

Cod. MT	Mandrino Spindle Spindel	I	RPM MAX	Coppia Max Max Torque Max Drehmoment	Reversibile lato mandrino/contromandrino Reversible sub/main spindle side Umkehrbare Spindel-seite/ Gegenspindel-seite	Lubrificazione int. Coolant through Innenkuehlung	Lubrificazione est. Ext. coolant Aussenkuehlung	A	CHIAVI INCLUSE Keys included Schluesel einbegriffen	
DW 00190216	ER16	1:5.625	22500	6Nm	X	-	X	121.8	CHMNER16	CHUB17
DW 00190211	ER11	1:5.625	22500	6Nm	X	P=30bar	-	134	CHMNER11	CHUB11

DOOSAN BMT 55

MOD: PUMA 230-240M/MS-280LM - PUMA 1500-2000-2500M/MS/Y/SY - LINX 300 M - PUMA 2100 12ST. - PUMA H250TM
 PUMA TT1500-1800-2100MS/SY/SYY - PUMA TL2000-2500 (M) - MX1600/2100ST 12ST. - PUMA GT2100-2600 M - PUMA QL200HM

MODULO MOTORIZZATO ASSIALE MOLTIPLICATO I=1:5.625 H=85mm

Axial geared-up I=1:5.625 driven tool H=85mm

Axial angetriebenes Werkzeug uebersetzt I=1:5.625 H=85mm

Subject to change without notice.

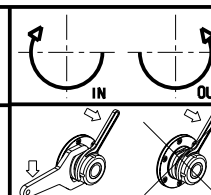

M.T. srl

Via Casino Albini 480
 Tel. 0541/956034-957884
 Fax 0541/956341
 47842 S. GIOVANNI, IN M. (RN)
 e-mail: mtma@mtmarchetti.com
 http://www.mtmarchetti.com

PRODUZIONE MODULI ROTANTI



PAGINA DW 0210-2-30

ATTENZIONE - ATTENTION - ACHTUNG

- VERIFICARE LE MISURE DI INGOMBRO PER POSSIBILE INTERFERENZA SU ALCUNI MODELLI DI MACCHINE
- Please check the overall sizes for possible interferences on some machine models
- Bitte überprüfen sie das ausmass um mögliche interferenzen auf einigen maschinen modellen zu vermeiden

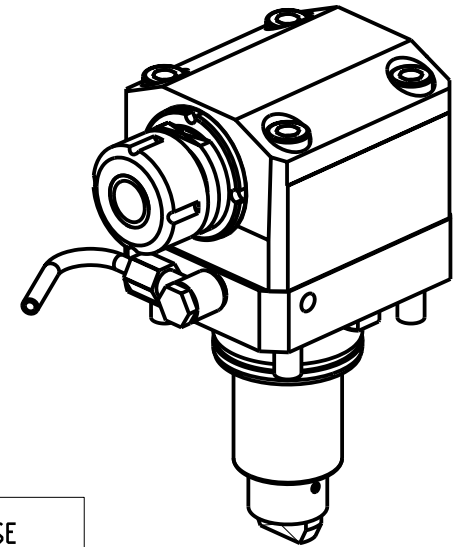
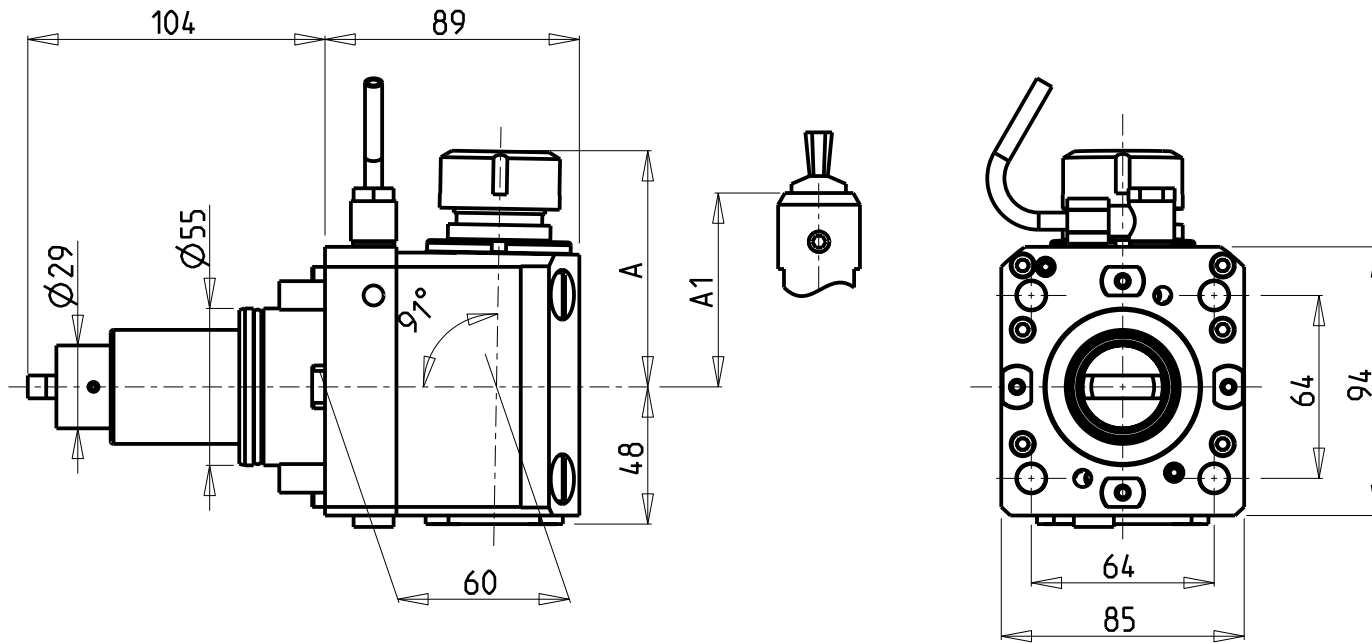

Cod. MT	Mandrino Spindle Spindel	I	RPM	Coppia Max Max Torque Max Drehmoment	Reversibile lato mandrino/contromandrino Reversible sub/main spindle side Umkehrbare Spindel-seite/Gegenspindel-seite	Lubrificazione est. Ext. coolant Auslenkuehlung	A	A1	CHIAVI NON INCLUSE Keys not included Schluessel nicht einbegriffen	
0319125	ER25	1:1	6000	50Nm	X	X	82.35	-	CHSTER25	CHUB36 o 0100000
0319108	WELDON 8	1:1	6000	50Nm	X	X	-	76.5	-	-
0319110	WELDON 10	1:1	6000	50Nm	X	X	-	76.5	-	-
0319112	WELDON 12	1:1	6000	50Nm	X	X	-	76.5	-	-
0319116	WELDON 16	1:1	6000	50Nm	X	X	-	73.5	-	-

DOOSAN BMT 55

MOD: PUMA 230-240M/MS-280LM - PUMA 1500-2000-2500M/MS/Y/SY - LINX 300 M - PUMA 2100 12ST. - PUMA 2600 16ST.
PUMA TL2000-2500 (M) - PUMA GT2100-2600 M

MODULO MOTORIZZATO ASSIALE PER POLIGONATURA INTERNA H=60mm

Axial driven tool for internal polygon-making H=60mm

Axial angetriebenes Werkzeug fuer interne Facettierung H=60mm

Subject to change without notice.

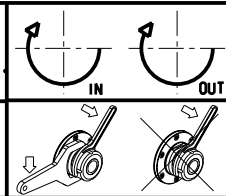

M.T. srl

Via Casino Albini 480
Tel. 0541/956034-957884
Fax 0541/956341
47842 S. GIOVANNI IN M. (RN)
e-mail: mtma@mtmarchetti.com
http://www.mtmarchetti.com

PRODUZIONE MODULI ROTANTI



PAGINA DW 0230-2-10

ATTENZIONE - ATTENTION - ACHTUNG

- VERIFICARE LE MISURE DI INGOMBRO PER POSSIBILE INTERFERENZA SU ALCUNI MODELLI DI MACCHINE
- Please check the overall sizes for possible interferences on some machine models
- Bitte überprüfen sie das ausmass um mögliche interenzen auf einigen maschinen modellen zu vermeiden

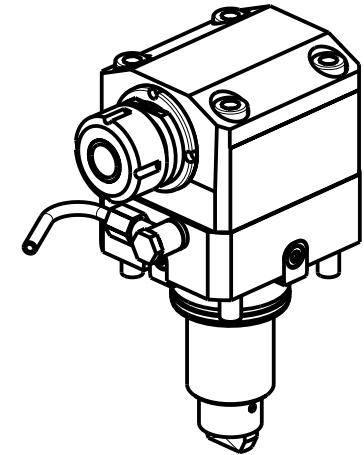
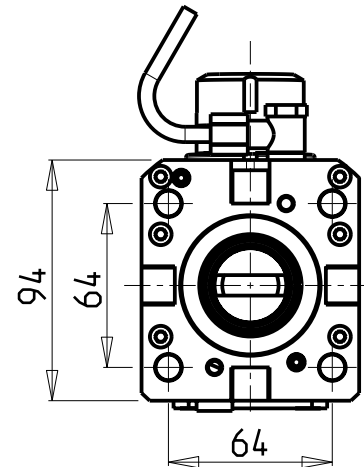
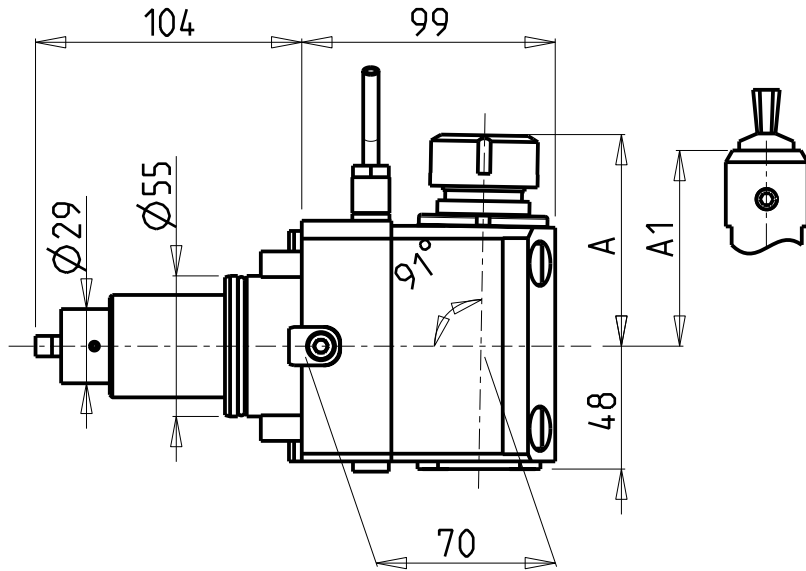

Cod. MT	Mandrino Spindle Spindel	I	RPM	Coppia Max Max Torque Max Drehmoment	Reversibile lato mandrino/contromandrino Reversible sub/main spindle side Umkehrbare Spindel-seite/Gegenspindel-seite	Lubrificazione est. Ext. coolant Ausseukuehlung	A	A1	CHIAVI NON INCLUSE Keys not included Schluessel nicht einbegriffen	
DW00249125	ER25	1:1	6000	50Nm	X	X	82.35	-	CHSTER25	CHUB36 o 0100000
DW00249108	WELDON 8	1:1	6000	50Nm	X	X	-	76.5	-	-
DW00249110	WELDON 10	1:1	6000	50Nm	X	X	-	76.5	-	-
DW00249112	WELDON 12	1:1	6000	50Nm	X	X	-	76.5	-	-
DW00249116	WELDON 16	1:1	6000	50Nm	X	X	-	76.5	-	-

DOOSAN BMT 55

MOD: PUMA 230-240M/MS-280LM - PUMA 1500-2000-2500M/MS/Y/SY - LINX 300 M - PUMA 2100 12ST. - PUMA 2600 16ST.
PUMA TL2000-2500 (M) - PUMA GT2100-2600 M - PUMA H250TM - PUMA QL 200HM

MODULO MOTORIZZATO ASSIALE PER POLIGONATURA INTERNA H=70mm

Axial driven tool for internal polygon-making H=70mm

Axial angetriebenes Werkzeug fuer interne Facettierung H=70mm

Subject to change without notice.

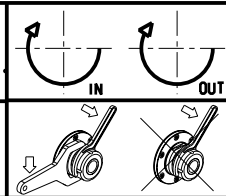

M.T. srl

Via Casino Albini 480
Tel. 0541/956034-957884
Fax 0541/956341
47842 S. GIOVANNI IN M. (RN)
e-mail: mtma@mtmarchetti.com
http://www.mtmarchetti.com

PRODUZIONE MODULI ROTANTI



PAGINA DW0230-2-20

ATTENZIONE - ATTENTION - ACHTUNG

- VERIFICARE LE MISURE DI INGOMBRO PER POSSIBILE INTERFERENZA SU ALCUNI MODELLI DI MACCHINE
- Please check the overall sizes for possible interferences on some machine models
- Bitte überprüfen sie das ausmass um mögliche interenzen auf einigen maschinen modellen zu vermeiden

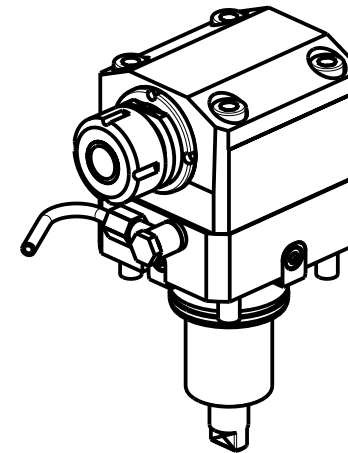
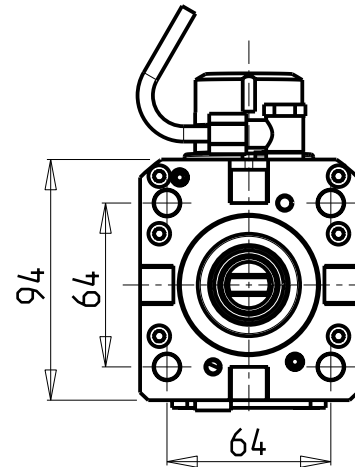
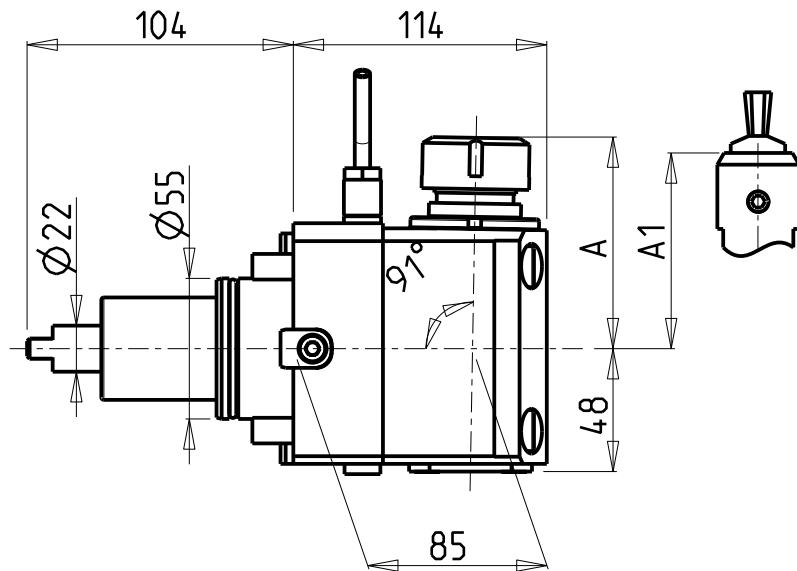

Cod. MT	Mandrino Spindle Spindel	I	RPM	Coppia Max Max Torque Max Drehmoment	Reversibile lato mandrino/contromandrino Reversible sub/main spindle side Umkehrbare Spindel-seite/Gegenspindel-seite	Lubrificazione est. Ext. coolant Auslenkuehlung	A	A1	CHIAVI NON INCLUSE Keys not included Schluessel nicht einbegriffen	
DW00029125	ER25	1:1	6000	50Nm	X	X	82.35	-	CHSTER25	CHUB36 o 0100000
DW00029108	WELDON 8	1:1	6000	50Nm	X	X	-	76.5	-	-
DW00029110	WELDON 10	1:1	6000	50Nm	X	X	-	76.5	-	-
DW00029112	WELDON 12	1:1	6000	50Nm	X	X	-	76.5	-	-
DW00029116	WELDON 16	1:1	6000	50Nm	X	X	-	73.5	-	-

DOOSAN BMT 55

MOD: PUMA 230-240M/MS-280LM - PUMA 1500-2000-2500M/MS/Y/SY - LINX 300 M - PUMA 2100 12ST. - PUMA H250TM
 PUMA TT1500-1800-2100MS/SY/SYY - PUMA TL2000-2500 (M) - MX1600/2100ST 12 ST. - PUMA GT2100-2600 M - PUMA QL200HM

MODULO MOTORIZZATO ASSIALE PER POLIGONATURA INTERNA H=85mm

Axial driven tool for internal polygon-making H=85mm

Axial angetriebenes Werkzeug fuer interne Facettierung H=85mm

Subject to change without notice.

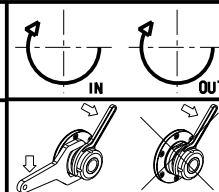

M.T. srl

Via Casino Albini 480
 Tel. 0541/956034-957884
 Fax 0541/956341
 47842 S. GIOVANNI IN M. (RN)
 e-mail: mtma@mtmarchetti.com
 http://www.mtmarchetti.com

PRODUZIONE MODULI ROTANTI



PAGINA DW0230-2-30

ATTENZIONE - ATTENTION - ACHTUNG

- FINO AD ESAURIMENTO SCORTE
- clearance sale
- solange vorrat

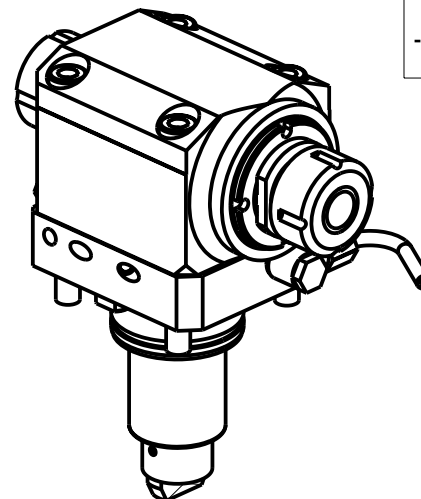
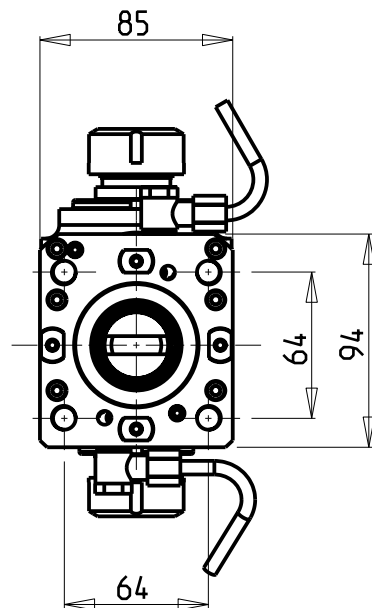
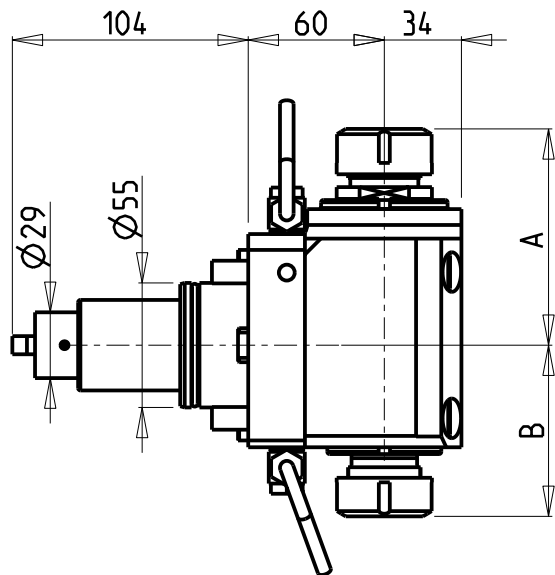

ATTENZIONE - ATTENTION - ACHTUNG

- Per lo smontaggio degli utensili utilizzare sempre la chiave di contrasto come indicato nel manuale d'uso.
- For disassembly of the tools use always the contrast key as mentioned in the user instructions.
- Fuer das Abmontieren der Werkzeuge immer den Gegenschlüssel benutzen wie in der Bedienungsanleitung erwäehnt.

Cod. MT	Mandrino Spindle Spindel	I	RPM	Coppia Max Max Torque Max Drehmoment	Reversibile lato mandrino/contromandrino Reversible sub/main spindle side Umkehrbare Spindel-seite/ Gegenspindel-seite	Lubrificazione est. Ext. coolant Ausseukuehlung	A	B	CHIAVI NON INCLUSE Keys not included Schluessel nicht einbegriffen	
DW00080132	ER32+ER32	1:1	6000	50Nm	X	X	100.56	79.46	CHSTER32	CHUB36 o 0100000
DW00080125	ER25+ER25	1:1	6000	50Nm	X	X	93.36	73.46	CHSTER25	CHUB36+CHUB29

DOOSAN BMT 55

MOD: PUMA 230-240M/MS-280LM - PUMA 1500-2000-2500M/MS/Y/SY - LINX300 M - PUMA 2100 12ST. - PUMA 2600 16ST.
PUMA TL2000-2500 (M)

MODULO MOTORIZZATO ASSIALE BISPORGENTE H=60mm

Axial opposite face twin driven tool H=60mm

Axial angetriebenes Werkzeug halb vorspringend H=60mm

Subject to change without notice.

M.T. srl

Via Casino Albini 480
Tel. 0541/956034-957884
Fax 0541/956341
47842 S. GIOVANNI IN M. (RN)
e-mail: mtma@mtmarchetti.com
http://www.mtmarchetti.com

PRODUZIONE MODULI ROTANTI



PAGINA DW0240-2-10

ATTENZIONE - ATTENTION - ACHTUNG

- Per lo smontaggio degli utensili utilizzare sempre la chiave di contrasto come indicato nel manuale d'uso.
- For disassembly of the tools use always the contrast key as mentioned in the user instructions.
- Fuer das Abmontieren der Werkzeuge immer den Gegenschlüssel benutzen wie in der Bedienungsanleitung erwaeht.

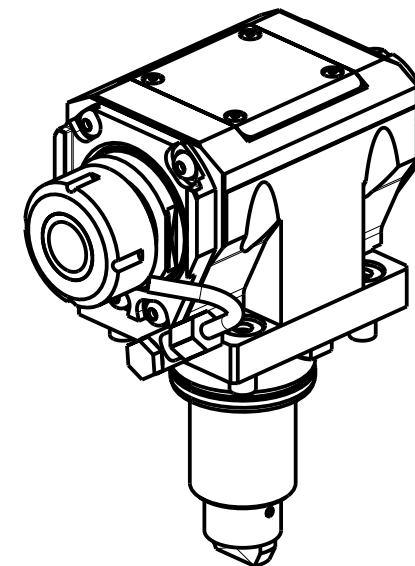
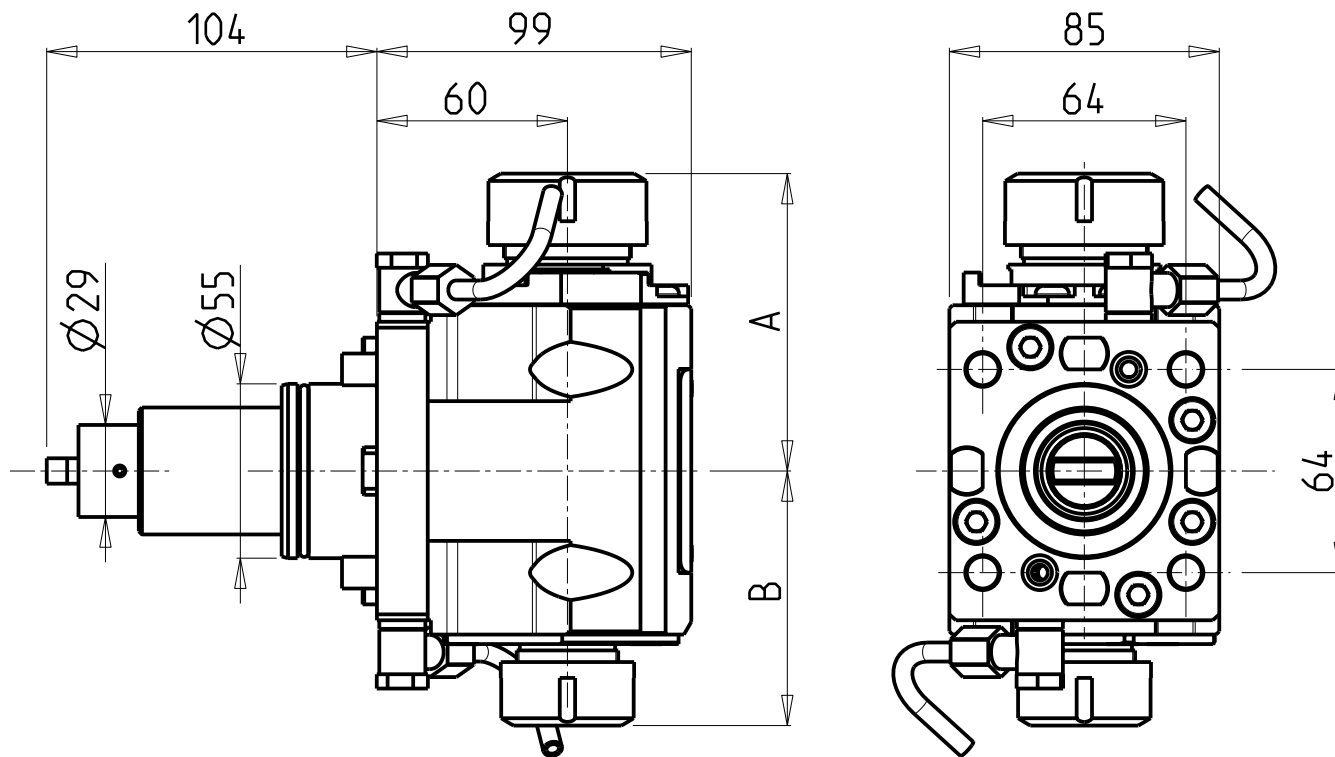

- Chiave inclusa
- Key included
- Schluessel inbegriffen

Cod. MT	Mandrino Spindle Spindel	I	RPM	Coppia Max Max Torque Max Drehmoment	Reversibile lato mandrino/contromandrino Reversible sub/main spindle side Umkehrbare Spindel-seite/ Gegenspindel-seite	Lubrificazione est. Ext. coolant Ausseukuehlung	A	B	CHIAVI NON INCLUSE Keys not included Schluessel nicht einbegriffen				
DW 01703225	ER32+ER25	1:1	6000	50Nm	X	X	93.66	80.16	CHSTER32	CHSTER25	OKU0650004	-	-
DW 01702520	ERA25+ERA20	1:1	6000	50Nm	X	X	65	55.5	CHUB22	CHUB27	OKU0650004	CHTAER20ZC	CHTAER25ZC

DOOSAN BMT 55
 MOD: PUMA 230-240M/MS-280LM - PUMA 1500-2000-2500M/MS/Y/SY - LINX300 M - PUMA 2100 12ST - PUMA 2600 16ST.
 PUMA TL2000-2500 (M)

MODULO MOTORIZZATO ASSIALE BISPORGENTE H=60mm
 Axial opposite face twin driven tool H=60mm
 Axial angetriebenes Werkzeug halb vorspringend H=60mm

Subject to change without notice.

M.T. srl
 Via Casino Albini 480
 Tel. 0541/956034-957884
 Fax 0541/956341
 47842 S. GIOVANNI IN M. (RN)
 e-mail: mtma@mtmarchetti.com
 http://www.mtmarchetti.com

PRODUZIONE MODULI ROTANTI



PAGINA DW0240-2-11

ATTENZIONE - ATTENTION - ACHTUNG

- FINO AD ESAURIMENTO SCORTE
- clearance sale
- solange vorrat

ATTENZIONE - ATTENTION - ACHTUNG

- VERIFICARE LE MISURE DI INGOMBRO PER POSSIBILE INTERFERENZA SU ALCUNI MODELLI DI MACCHINE
- Please check the overall sizes for possible interferences on some machine models
- Bitte überprüfen sie das ausmass um mögliche interferenzen auf einigen maschinen modellen zu vermeiden

ATTENZIONE - ATTENTION - ACHTUNG

- Per lo smontaggio degli utensili utilizzare sempre la chiave di contrasto come indicato nel manuale d'uso.
- For disassembly of the tools use always the contrast key as mentioned in the user instructions.
- Fuer das Abmontieren der Werkzeuge immer den Gegenschlüssel benutzen wie in der Bedienungsanleitung erwaeht.

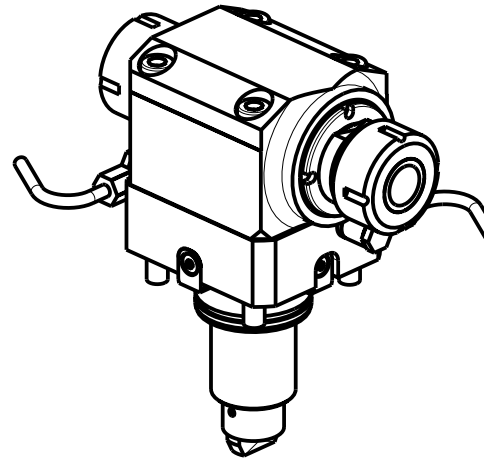
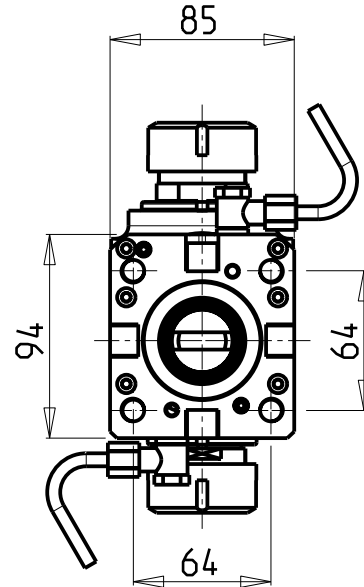
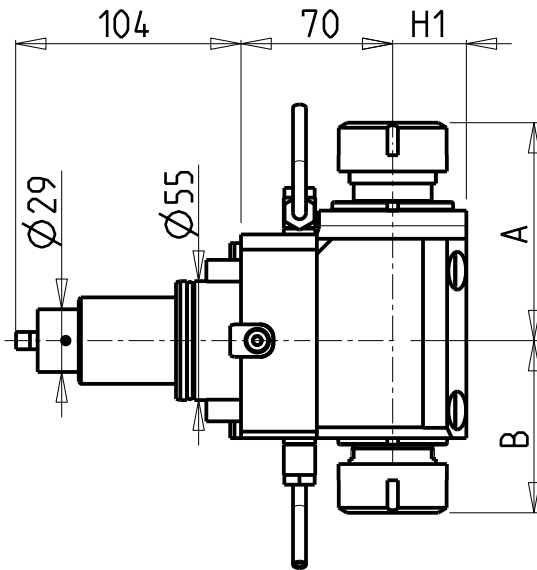

Cod. MT	Mandrino Spindle Spindel	I	RPM	Coppia Max Max Torque Max Drehmoment	Reversibile lato mandrino/contromandrino Reversible sub/main spindle side Umkehrbare Spindel-seite/ Gegenspindel-seite	Lubrificazione est. Ext. coolant Ausseukuehlung	A	B	H1	CHIAVI NON INCLUSE Keys not included Schlüssel nicht einbegriffen	
DW00080332	ER32+ER32	1:1	6000	50Nm	X	X	100.56	79.46	34	CHSTER32	CHUB36 o 0100000
DW00080325	ER25+ER25	1:1	6000	50Nm	X	X	93.36	73.46	34	CHSTER25	CHUB36+CHUB29

DOOSAN BMT 55

MOD: PUMA 230-240M/MS-280LM - PUMA 1500-2000-2500M/MS/Y/SY - LINX300 M - PUMA 2100 12ST. - PUMA 2600 16ST.
PUMA TL2000-2500 (M)

MODULO MOTORIZZATO ASSIALE BISPORGENTE H=70mm

Axial opposite face twin driven tool H=70mm

Axial angetriebenes Werkzeug halb vorspringend H=70mm

Subject to change without notice.

M.T. srl

Via Casino Albini 480
Tel. 0541/956034-957884
Fax 0541/956341
47842 S. GIOVANNI IN M. (RN)
e-mail: mtma@mtmarchetti.com
http://www.mtmarchetti.com

PRODUZIONE MODULI ROTANTI



PAGINA DW0240-2-20

ATTENZIONE - ATTENTION - ACHTUNG

- Per lo smontaggio degli utensili utilizzare sempre la chiave di contrasto come indicato nel manuale d'uso.
- For disassembly of the tools use always the contrast key as mentioned in the user instructions.
- Fuer das Abmontieren der Werkzeuge immer den Gegenschlüssel benutzen wie in der Bedienungsanleitung erwaeht.

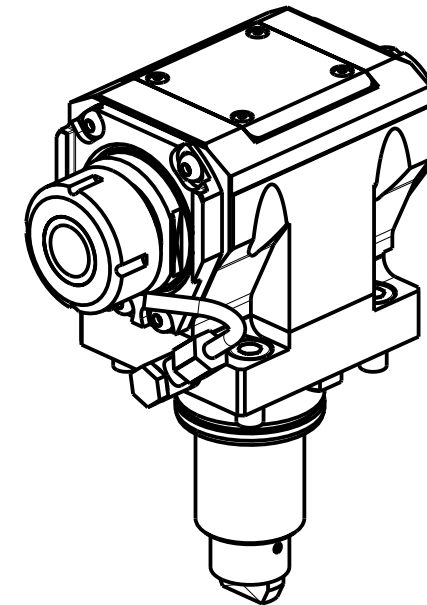
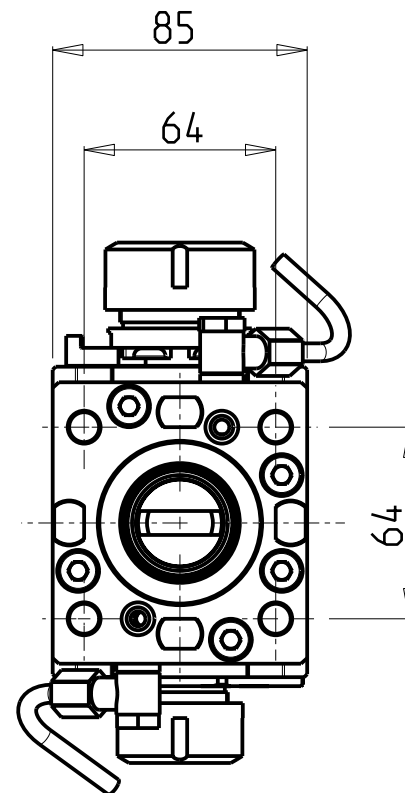
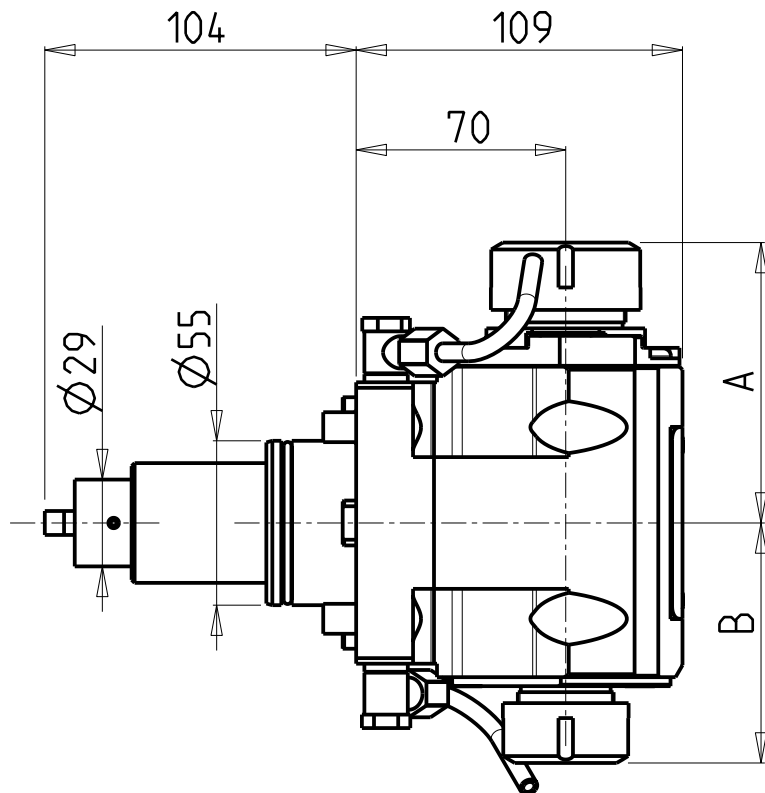

- Chiave inclusa
- Key included
- Schlüssel inbegriffen

Cod. MT	Mandrino Spindle Spindel	I	RPM	Coppia Max Max Torque Max Drehmoment	Reversibile lato mandrino/contromandrino Reversible sub/main spindle side Umkehrbare Spindelsetseite/ Gegenspindelsetseite	Lubrificazione est. Ext. coolant Aussehenkuehlung	A	B	CHIAVI NON INCLUSE Keys not included Schlüssel nicht einbegriffen					
DW 01713225	ER32+ER25	1:1	6000	50Nm	X	X	93.66	80.16	CHSTER32	CHSTER25	OKU0650004	-	-	-
DW 01712520	ERA25+ERA20	1:1	6000	50Nm	X	X	65	55.5	CHUB22	CHUB27	OKU0650004	CHTAER20ZC	CHTAER25ZC	

DOOSAN BMT 55
 MOD: PUMA 230-240M/MS-280LM - PUMA 1500-2000-2500M/MS/Y/SY - LINX300 M - PUMA 2100 12ST. - PUMA 2600 16ST.
 PUMA TL2000-2500 (M)

MODULO MOTORIZZATO ASSIALE BISPORGENTE H=70mm
 Axial opposite face twin driven tool H=70mm
 Axial angetriebenes Werkzeug halb vorspringend H=70mm

Subject to change without notice.

M.T. srl
 Via Casino Albini 480
 Tel. 0541/956034-957884
 Fax 0541/956341
 47842 S. GIOVANNI IN M. (RN)
 e-mail: mtma@mtmarchetti.com
 http://www.mtmarchetti.com

PRODUZIONE MODULI ROTANTI



PAGINA DW0240-2-21

ATTENZIONE - ATTENTION - ACHTUNG

- FINO AD ESAURIMENTO SCORTE
- clearance sale
- solange vorrat

ATTENZIONE - ATTENTION - ACHTUNG

- VERIFICARE LE MISURE DI INGOMBRO PER POSSIBILE INTERFERENZA SU ALCUNI MODELLI DI MACCHINE
- Please check the overall sizes for possible interferences on some machine models
- Bitte überprüfen sie das ausmass um mögliche interferenzen auf einigen maschinen modellen zu vermeiden

ATTENZIONE - ATTENTION - ACHTUNG

- Per lo smontaggio degli utensili utilizzare sempre la chiave di contrasto come indicato nel manuale d'uso.
- For disassembly of the tools use always the contrast key as mentioned in the user instructions.
- Fuer das Abmontieren der Werkzeuge immer den Gegenschlüssel benutzen wie in der Bedienungsanleitung erwaeht.

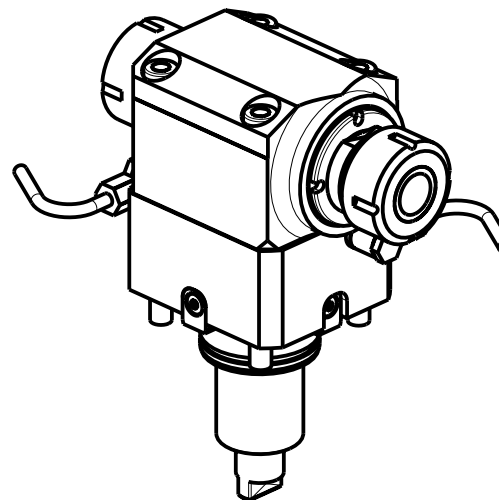
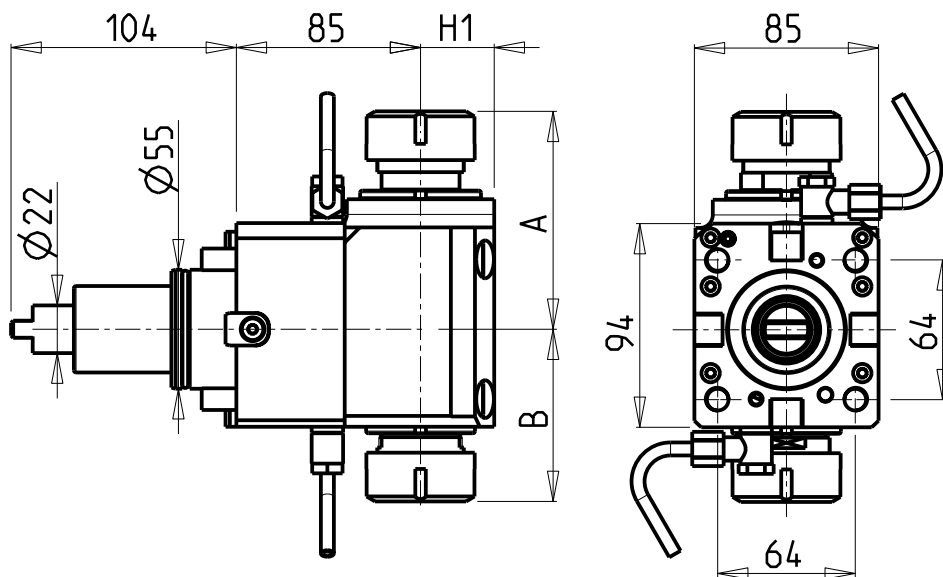

Cod. MT	Mandrino Spindle Spindel	I	RPM	Coppia Max Max Torque Max Drehmoment	Reversibile lato mandrino/contromandrino Reversible sub/main spindle side Umkehrbare Spindelseite/ Gegenspindelseite	Lubrificazione est. Ext. coolant Aussenkuehlung	A	B	H1	CHIAVI NON INCLUSE Keys not included Schlüssel nicht einbegriffen	
DW00080232	ER32+ER32	1:1	6000	50Nm	X	X	100.56	79.46	34	CHSTER32	CHUB36 o 0100000
DW00080225	ER25+ER25	1:1	6000	50Nm	X	X	93.36	73.46	34	CHSTER25	CHUB36+CHUB29

DOOSAN BMT 55

MOD: PUMA 230-240M/MS-280LM - PUMA 1500-2000-2500M/MS/Y/SY - LINX300 M - PUMA 2100 12ST.
PUMA TT1500-1800-2100MS/SY/SYY - PUMA TL2000-2500 (M) - MX1600/2100ST 12ST.

MODULO MOTORIZZATO ASSIALE BISPORGENTE H=85mm

Axial opposite face twin driven tool H=85mm

Axial angetriebenes Werkzeug halb vorspringend H=85mm

Subject to change without notice.

M.T. srl

Via Casino Albini 480
Tel. 0541/956034-957884
Fax 0541/956341
47842 S. GIOVANNI IN M. (RN)
e-mail: mtma@mtmarchetti.com
http://www.mtmarchetti.com

PRODUZIONE MODULI ROTANTI



PAGINA DW0240-2-30

ATTENZIONE - ATTENTION - ACHTUNG

- Per lo smontaggio degli utensili utilizzare sempre la chiave di contrasto come indicato nel manuale d'uso.
- For disassembly of the tools use always the contrast key as mentioned in the user instructions.
- Fuer das Abmontieren der Werkzeuge immer den Gegenschlüssel benutzen wie in der Bedienungsanleitung erwaeht.

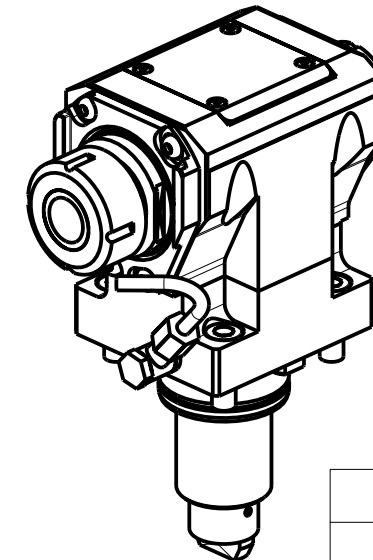
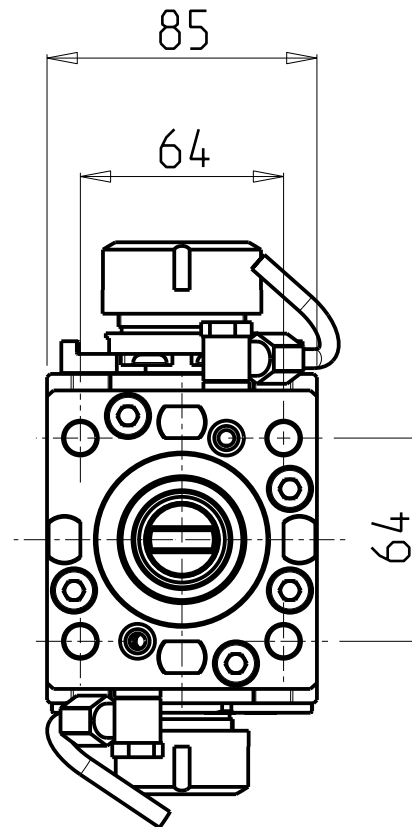
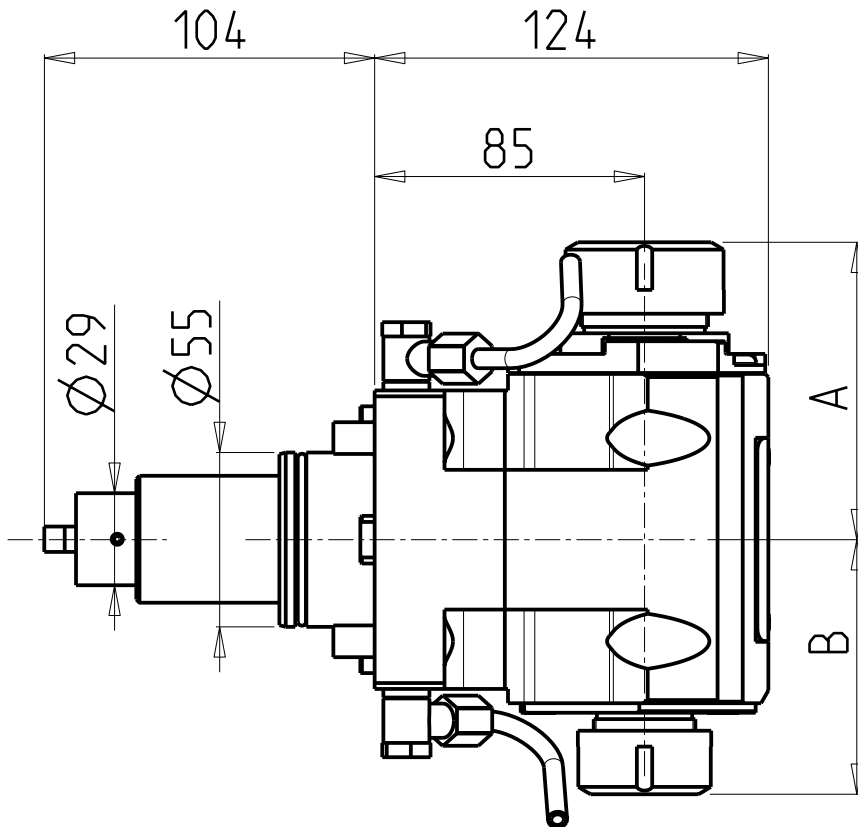

- Chiave inclusa
- Key included
- Schlüssel inbegriffen

CHIAVI NON INCLUSE
Keys not included
Schlüssel nicht einbegriffen

Cod. MT	Mandrino Spindle Spindel	I	RPM	Coppia Max Max Torque Max Drehmoment	Reversibile lato mandrino/contromandrino Reversible sub/main spindle side Umkehrbare Spindelsete/Gegenspindelsete	Lubrificazione est. Ext. coolant Ausseukuehlung	A	B					
DW 01723225	ER32+ER25	1:1	6000	50Nm	X	X	93.66	80.16	CHSTER32	CHSTER25	OKU0650004	-	-
DW 01722520	ERA25+ERA20	1:1	6000	50Nm	X	X	65	55.5	CHUB22	CHUB27	OKU0650004	CHTAER20ZC	CHTAER25ZC

DOOSAN BMT 55
 MOD: PUMA 230-240M/MS-280LM - PUMA 1500-2000-2500M/MS/Y/SY - LINX300 M - PUMA 2100 12ST.
 PUMA TT1500-1800-2100MS/SY/SYY - PUMA TL2000-2500 (M) - MX1600/2100ST 12ST.

MODULO MOTORIZZATO ASSIALE BISPORGENTE H=85mm
 Axial opposite face twin driven tool H=85mm
 Axial angetriebenes Werkzeug halb vorspringend H=85mm

M.T. srl
 Via Casino Albini 480
 Tel. 0541/956034-957884
 Fax 0541/956341
 47842 S. GIOVANNI IN M. (RN)
 e-mail: mtma@mtmarchetti.com
 http://www.mtmarchetti.com

PRODUZIONE MODULI ROTANTI



PAGINA DW 0240-2-31

Subject to change without notice.

04/2020

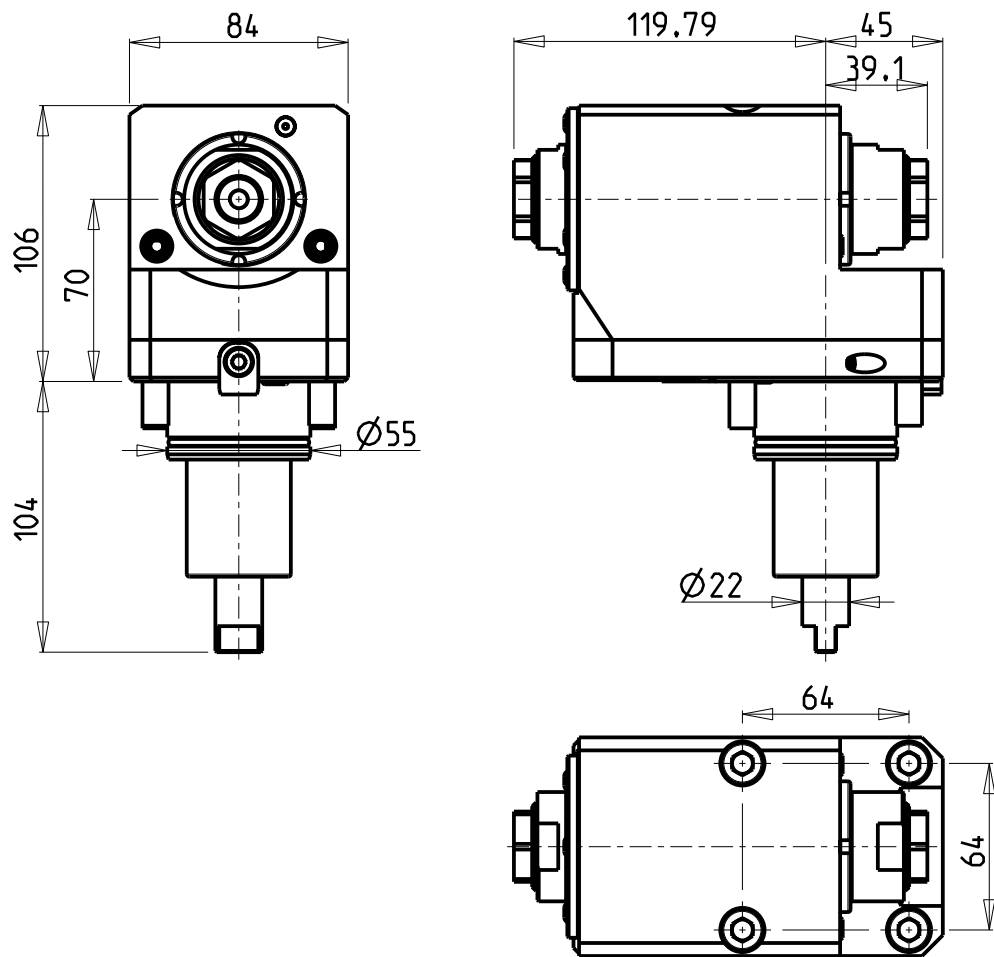

ATTENZIONE - ATTENTION - ACHTUNG

- Per lo smontaggio degli utensili utilizzare sempre la chiave di contrasto come indicato nel manuale d'uso.
- For disassembly of the tools use always the contrast key as mentioned in the user instructions.
- Fuer das Abmontieren der Werkzeuge immer den Gegenschlüssel benutzen wie in der Bedienungsanleitung erwäehnt.

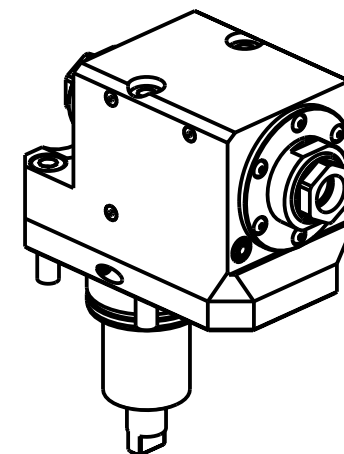
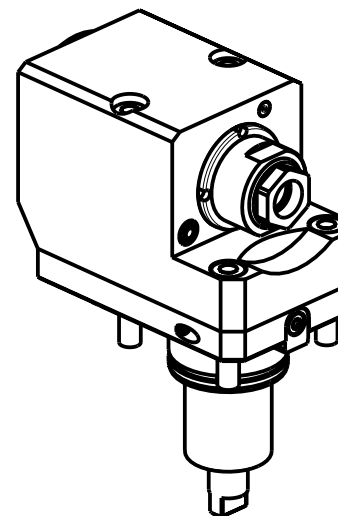

Cod. MT	Mandrino Spindle Spindel	I	RPM	Coppia Max Max Torque Max Drehmoment	Reversibile lato mandrino/contromandrino Reversible sub/main spindle side Umkehrbare Spindel-seite/ Gegenspindel-seite	Lubrificazione est. Ext. coolant Ausseukuehlung	CHIAVI NON INCLUSE Keys not included Schluessel nicht inbegriffen	
0632525	ERA25+ERA25	1:1	6000	50Nm	X	X	CHUB27	CHUB38

DOOSAN BMT 55

MOD: PUMA 230-240M/MS-280LM - PUMA 1500-2000-2500M/MS/Y/SY - LINX 300 M - PUMA 2100 12ST. - PUMA 2600 16ST. TL2000-2500 (M)

MODULO MOTORIZZATO ASSIALE ARRETRATO BISPORGENTE

Axial opposite face rear-set driven tool

Axial angetriebenes Werkzeug zurueckversetzt halb vorspringend

Subject to change without notice.

M.T. srl

Via Casino Albini 480
Tel. 0541/956034-957884
Fax 0541/956341
47842 S. GIOVANNI IN M. (RN)
e-mail: mtma@mtmarchetti.com
http://www.mtmarchetti.com

PRODUZIONE MODULI ROTANTI



PAGINA DW0243-2-10

ATTENZIONE - ATTENTION - ACHTUNG

- Per lo smontaggio degli utensili utilizzare sempre la chiave di contrasto come indicato nel manuale d'uso.
- For disassembly of the tools use always the contrast key as mentioned in the user instructions.
- Fuer das Abmontieren der Werkzeuge immer den Gegenschlüssel benutzen wie in der Bedienungsanleitung erwaeht.

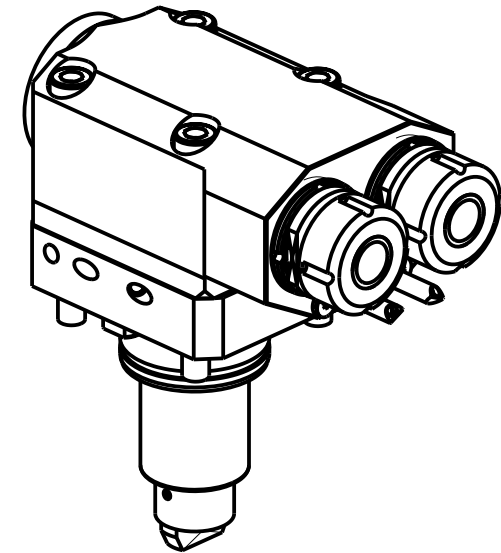
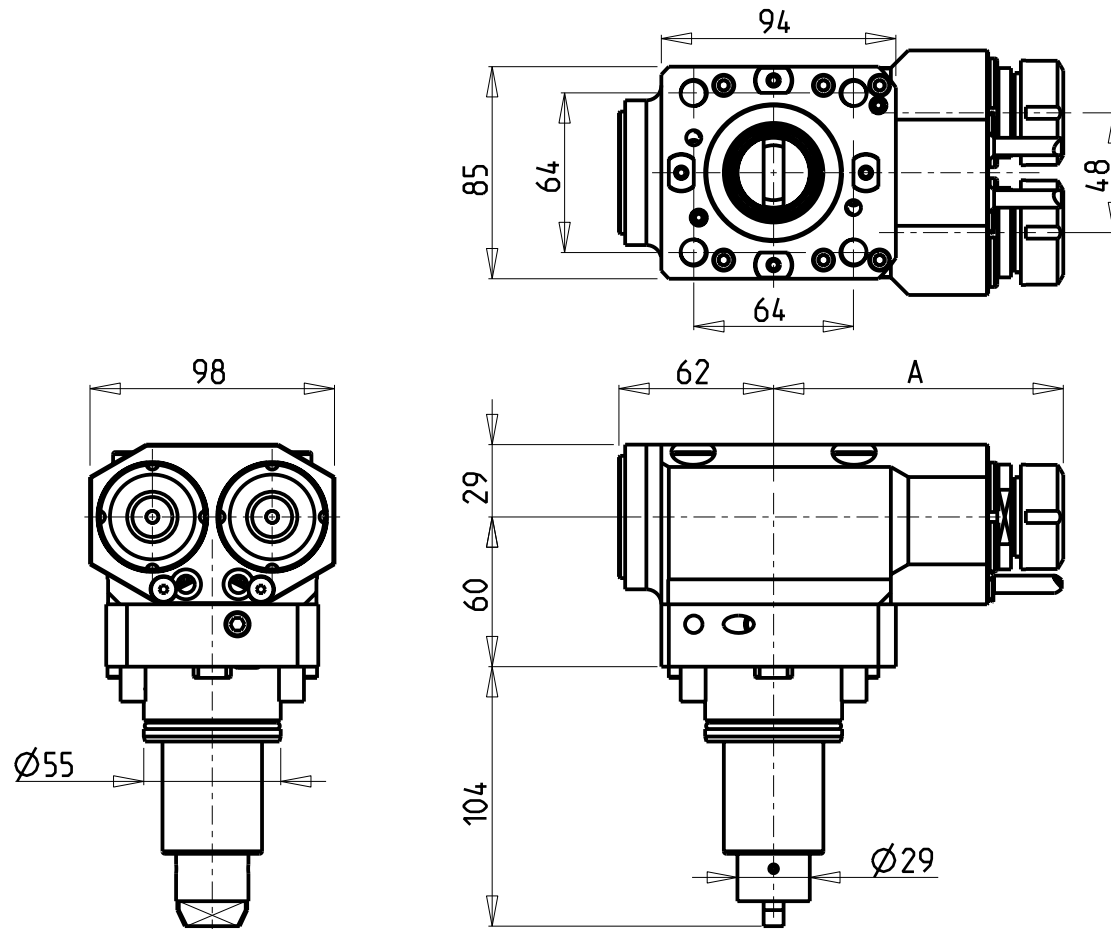

Cod. MT	Mandrino Spindle Spindel	I	RPM	Coppia Max Max Torque Max Drehmoment	Reversibile lato mandrino/contromandrino Reversible sub/main spindle side Umkehrbare Spindel-seite/ Gegenspindel-seite	Lubrificazione est. Ext. coolant Aussenkuehlung	A	CHIAVI NON INCLUSE Keys not included Schluessel nicht einbegriffen	
								CHMNER16	CHUB17
DW00100216	ER16	1:1	6000	30Nm	X	X	115.15	CHMNER16	CHUB17
DW00100225	ER25	1:1	6000	30Nm	X	X	115.61	CHSTER25	MNL0210007

DOOSAN BMT 55

MOD: PUMA 1500-2000-2500M/MS/Y/SY - PUMA 2100 12ST. - PUMA 2600 16ST.

MODULO MOTORIZZATO ASSIALE 2 USCITE IN Y H=60mm

Axial single side twin head driven tool in Y H=60mm

Axial angetriebenes Werkzeug 2 Ausgaenge in Y H=60mm

Subject to change without notice.

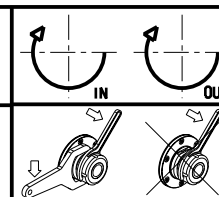

M.T. srl

Via Casino Albini 480
Tel. 0541/956034-957884
Fax 0541/956341
47842 S. GIOVANNI IN M. (RN)
e-mail: mtma@mtmarchetti.com
http://www.mtmarchetti.com

PRODUZIONE MODULI ROTANTI



PAGINA DW0260-2-10

ATTENZIONE - ATTENTION - ACHTUNG

- Per lo smontaggio degli utensili utilizzare sempre la chiave di contrasto come indicato nel manuale d'uso.
- For disassembly of the tools use always the contrast key as mentioned in the user instructions.
- Fuer das Abmontieren der Werkzeuge immer den Gegenschluesel benutzen wie in der Bedienungsanleitung erwaehnt.

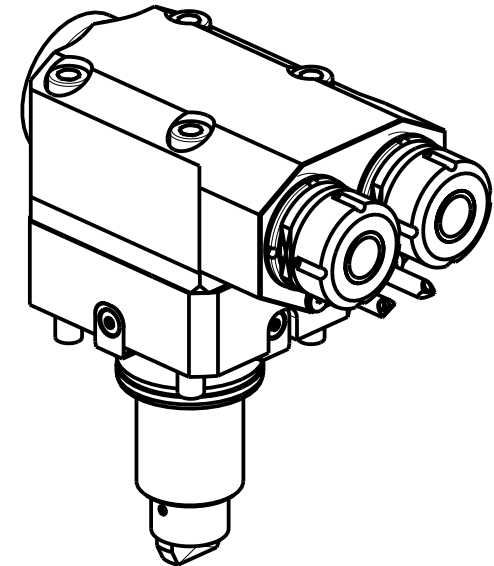
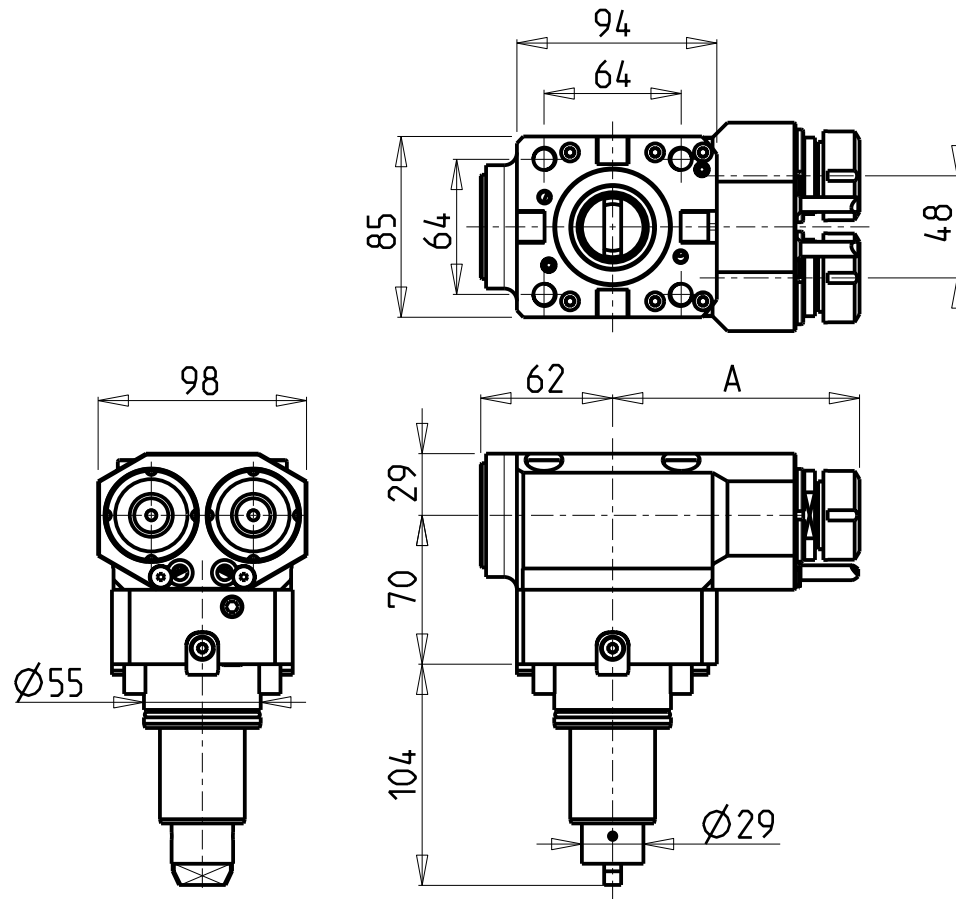

Cod. MT	Mandrino Spindle Spindel	I	RPM	Coppia Max Max Torque Max Drehmoment	Reversibile lato mandrino/contromandrino Reversible sub/main spindle side Umkehrbare Spindel-seite/ Gegenspindel-seite	Lubrificazione est. Ext. coolant Aussenkuehlung	A	CHIAVI NON INCLUSE Keys not included Schluesel nicht einbegriffen	
								CHMNER16	CHUB17
DW00102216	ER16	1:1	6000	30Nm	X	X	115.15	CHMNER16	CHUB17
DW00102225	ER25	1:1	6000	30Nm	X	X	115.61	CHSTER25	MNL0210007

DOOSAN BMT 55

MOD: PUMA 1500-2000-2500M/MS/Y/SY - PUMA 2100 12ST. - PUMA 2600 16ST.

MODULO MOTORIZZATO ASSIALE 2 USCITE IN Y H=70mm

Axial single side twin head driven tool in Y H=70mm

Axial angetriebenes Werkzeug 2 Ausgaenge in Y H=70mm

Subject to change without notice.

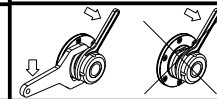
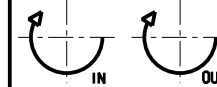

M.T. srl

Via Casino Albini 480
Tel. 0541/956034-957884
Fax 0541/956341
47842 S. GIOVANNI IN M. (RN)
e-mail: mtma@mtmarchetti.com
http://www.mtmarchetti.com

PRODUZIONE MODULI ROTANTI



PAGINA DW0260-2-20

ATTENZIONE - ATTENTION - ACHTUNG

- Per lo smontaggio degli utensili utilizzare sempre la chiave di contrasto come indicato nel manuale d'uso.
- For disassembly of the tools use always the contrast key as mentioned in the user instructions.
- Fuer das Abmontieren der Werkzeuge immer den Gegenschlüssel benutzen wie in der Bedienungsanleitung erwaeht.

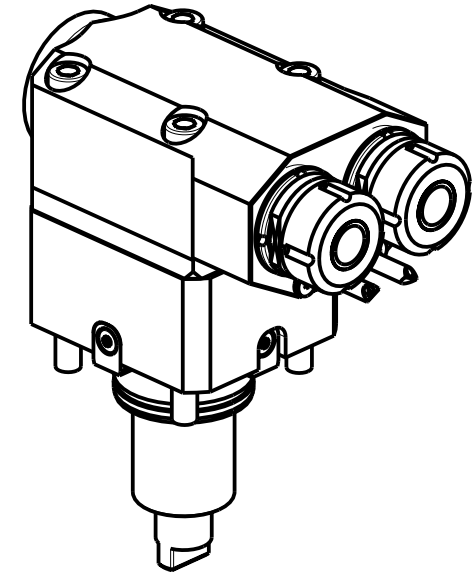
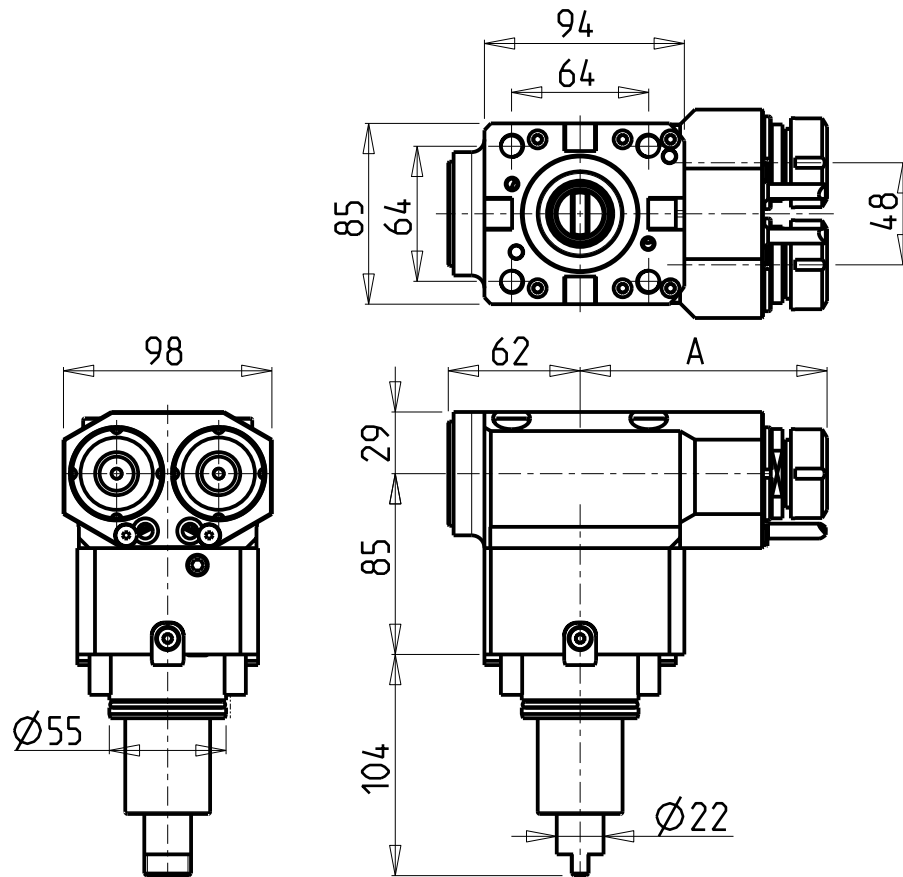

Cod. MT	Mandrino Spindle Spindel	I	RPM	Coppia Max Max Torque Max Drehmoment	Reversibile lato mandrino/contromandrino Reversible sub/main spindle side Umkehrbare Spindel-seite/ Gegenspindel-seite	Lubrificazione est. Ext. coolant Aussenkuehlung	A	CHIAVI NON INCLUSE Keys not included Schluessel nicht einbegriffen	
								CHMNER16	CHUB17
DW 00101216	ER16	1:1	6000	30Nm	X	X	115.15	CHMNER16	CHUB17
DW 00101225	ER25	1:1	6000	30Nm	X	X	115.61	CHSTER25	MNL0210007

DOOSAN BMT 55

MOD: PUMA 1500-2000-2500M/MS/Y/SY - PUMA 2100 12ST. - PUMA TT1500-1800-2100MS/SY/SYY

MODULO MOTORIZZATO ASSIALE 2 USCITE IN Y H=85mm

Axial single side twin head driven tool in Y H=85mm

Axial angetriebenes Werkzeug 2 Ausgaenge in Y H=85mm

Subject to change without notice.

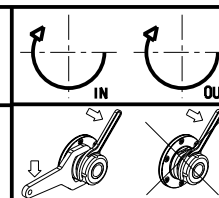

M.T. srl

Via Casino Albini 480
Tel. 0541/956034-957884
Fax 0541/956341
47842 S. GIOVANNI IN M. (RN)
e-mail: mtma@mtmarchetti.com
http://www.mtmarchetti.com

PRODUZIONE MODULI ROTANTI



PAGINA DW0260-2-30

ATTENZIONE - ATTENTION - ACHTUNG

- Per lo smontaggio degli utensili utilizzare sempre la chiave di contrasto come indicato nel manuale d'uso.
- For disassembly of the tools use always the contrast key as mentioned in the user instructions.
- Fuer das Abmontieren der Werkzeuge immer den Gegenschlüssel benutzen wie in der Bedienungsanleitung erwaeht.

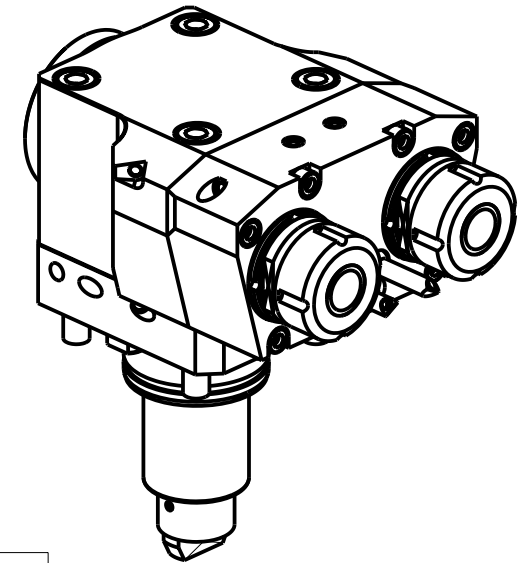
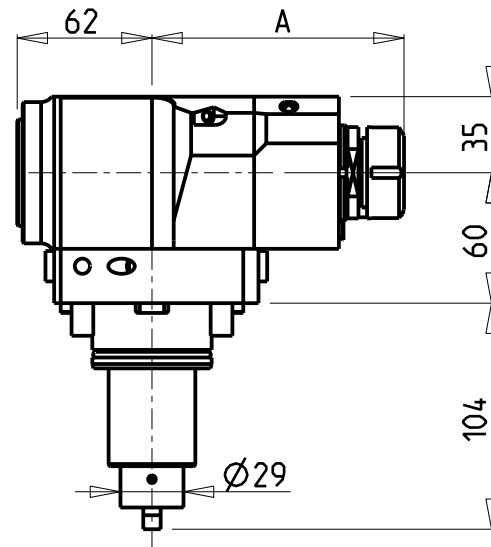
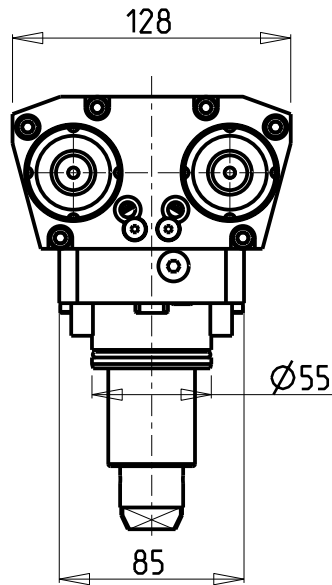
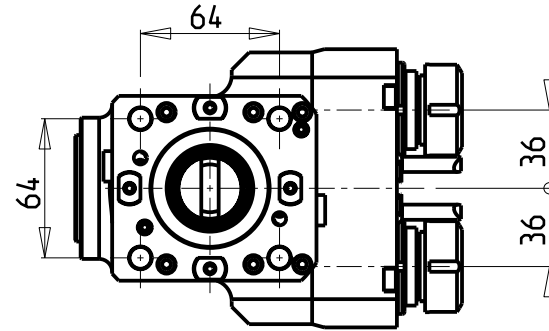

Cod. MT	Mandrino Spindle Spindel	I	RPM	Coppia Max Max Torque Max Drehmoment	Reversibile lato mandrino/contromandrino Reversible sub/main spindle side Umkehrbare Spindel-seite/ Gegenspindel-seite	Lubrificazione est. Ext. coolant Aussenkuehlung	A	CHIAVI NON INCLUSE Keys not included Schlüssel nicht einbegriffen	
								CHMNER16	CHUB17
DW00950216	ER16	1:2	12000	20Nm	X	X	115	CHMNER16	CHUB17
DW00950225	ER25	1:2	12000	20Nm	X	X	115.96	CHSTER25	CHUB36

DOOSAN BMT 55

MOD: PUMA 1500-2000-2500M/MS/Y/SY - PUMA 2100 12ST. - PUMA TL2000-2500 (M)

MODULO MOTORIZZATO ASSIALE 2 USCITE IN Y MOLTIPLICATO I=1:2 H=60mm

Axial geared-up I=1:2 single side twin head driven tool in Y H=60mm

Axial angetriebenes Werkzeug 2 Ausgaenge in Y uebersetzt I=1:2 H=60mm

Subject to change without notice.

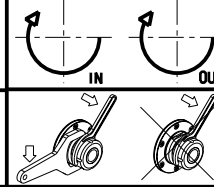

M.T. srl

Via Casino Albini 480
Tel. 0541/956034-957884
Fax 0541/956341
47842 S. GIOVANNI IN M. (RN)
e-mail: mtma@mtmarchetti.com
http://www.mtmarchetti.com

PRODUZIONE MODULI ROTANTI



PAGINA DW0261-2-10

ATTENZIONE - ATTENTION - ACHTUNG

- Per lo smontaggio degli utensili utilizzare sempre la chiave di contrasto come indicato nel manuale d'uso.
- For disassembly of the tools use always the contrast key as mentioned in the user instructions.
- Fuer das Abmontieren der Werkzeuge immer den Gegenschlüssel benutzen wie in der Bedienungsanleitung erwahnt.

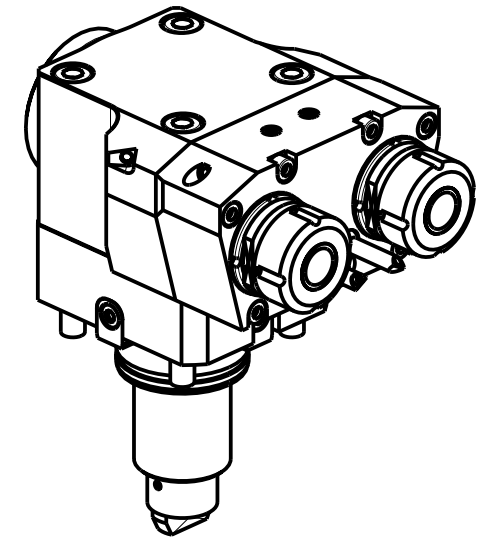
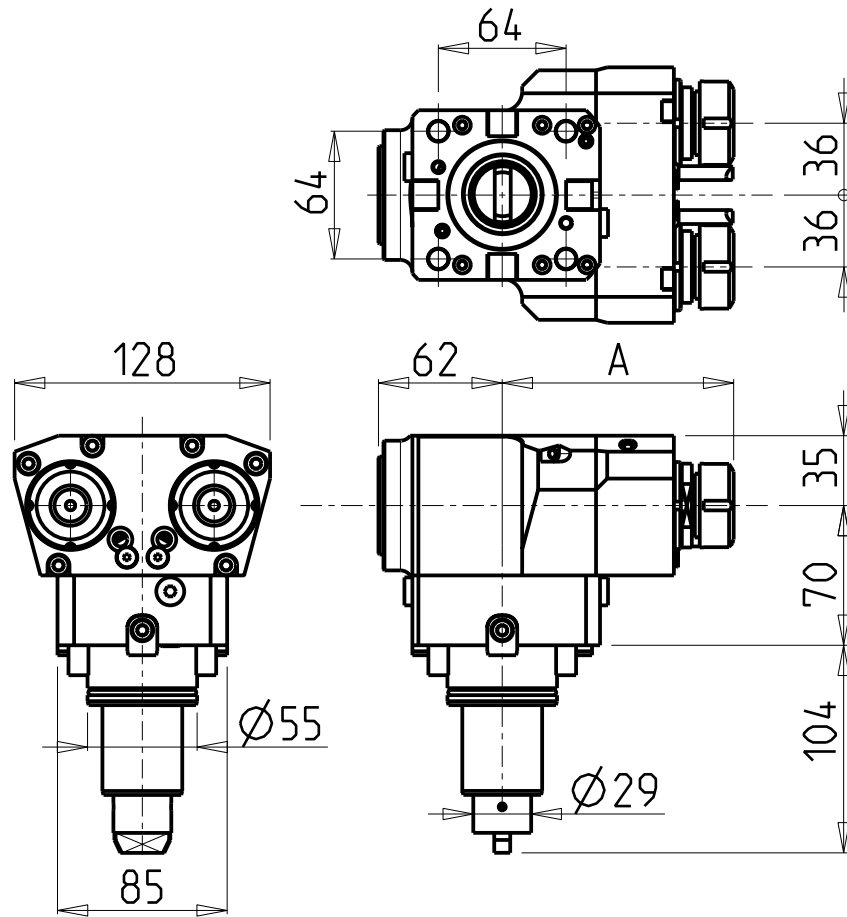

Cod. MT	Mandrino Spindle Spindel	I	RPM	Coppia Max Max Torque Max Drehmoment	Reversibile lato mandrino/contromandrino Reversible sub/main spindle side Umkehrbare Spindelsete/ Gegenspindelsete	Lubrificazione est. Ext. coolant Aussenkuehlung	A	CHIAVI NON INCLUSE Keys not included Schluessel nicht einbegriffen	
								CHMNER16	CHUB17
DW 00951216	ER16	1:2	12000	20Nm	X	X	115	CHMNER16	CHUB17
DW 00951225	ER25	1:2	12000	20Nm	X	X	115.96	CHSTER25	CHUB36

DOOSAN BMT 55

MOD: PUMA 1500-2000-2500M/MS/Y/SY - PUMA 2100 12ST. - PUMA TL2000-2500 (M)

MODULO MOTORIZZATO ASSIALE 2 USCITE IN Y MOLTIPLICATO I=1:2 H=70mm

Axial geared-up I=1:2 single side twin head driven tool in Y H=70mm

Axial angetriebenes Werkzeug 2 Ausgaenge in Y uebersetzt I=1:2 H=70mm

Subject to change without notice.

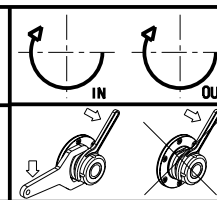

M.T. srl

Via Casino Albini 480
Tel. 0541/956034-957884
Fax 0541/956341
47842 S. GIOVANNI IN M. (RN)
e-mail: mtma@mtmarchetti.com
http://www.mtmarchetti.com

PRODUZIONE MODULI ROTANTI



PAGINA DW0261-2-20

ATTENZIONE - ATTENTION - ACHTUNG

- Per lo smontaggio degli utensili utilizzare sempre la chiave di contrasto come indicato nel manuale d'uso.
- For disassembly of the tools use always the contrast key as mentioned in the user instructions.
- Fuer das Abmontieren der Werkzeuge immer den Gegenschlüssel benutzen wie in der Bedienungsanleitung erwäehnt.

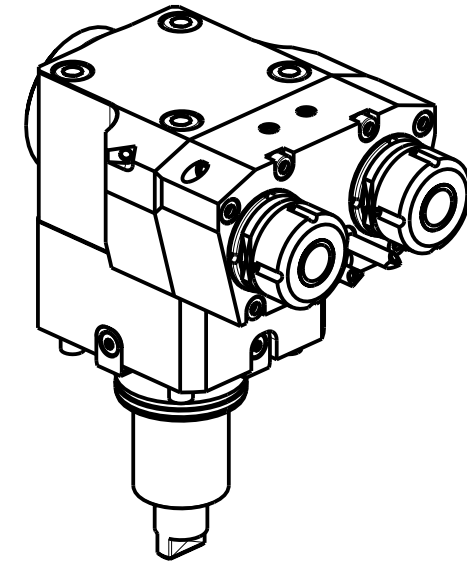
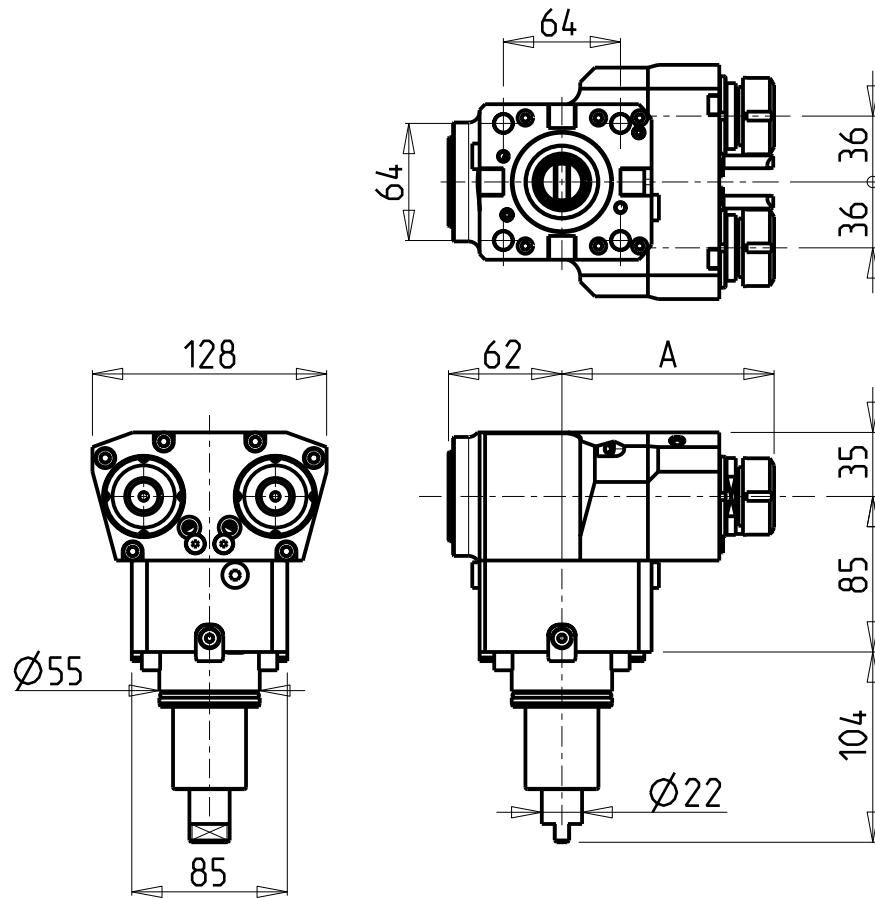

Cod. MT	Mandrino Spindle Spindel	I	RPM	Coppia Max Max Torque Max Drehmoment	Reversibile lato mandrino/contromandrino Reversible sub/main spindle side Umkehrbare Spindel-seite/ Gegenspindel-seite	Lubrificazione est. Ext. coolant Aussenkuehlung	A	CHIAVI NON INCLUSE Keys not included Schluessel nicht einbegriffen	
								CHMNER16	CHUB17
DW00952216	ER16	1:2	12000	20Nm	X	X	115	CHMNER16	CHUB17
DW00952225	ER25	1:2	12000	20Nm	X	X	115.96	CHSTER25	CHUB36

DOOSAN BMT 55

MOD: PUMA 1500-2000-2500M/MS/Y/SY - PUMA 2100 12ST. - PUMA TT1500-1800-2100MS/SY/SYY - PUMA TL2000-2500 (M)

MODULO MOTORIZZATO ASSIALE 2 USCITE IN Y MOLTIPLICATO I=1:2 H=85mm

Axial geared-up I=1:2 single side twin head driven tool in Y H=85mm

Axial angetriebenes Werkzeug 2 Ausgaenge in Y uebersetzt I=1:2 H=85mm

Subject to change without notice.

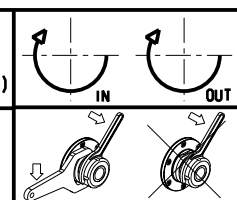

M.T. srl
 Via Casino Albini 480
 Tel. 0541/956034-957884
 Fax 0541/956341
 47842 S. GIOVANNI IN M. (RN)
 e-mail: mtma@mtmarchetti.com
 http://www.mtmarchetti.com

PRODUZIONE MODULI ROTANTI

PAGINA DW0261-2-30

ATTENZIONE - ATTENTION - ACHTUNG

- VERIFICARE LE MISURE DI INGOMBRO PER POSSIBILE INTERFERENZA SU ALCUNI MODELLI DI MACCHINE
- Please check the overall sizes for possible interferences on some machine models
- Bitte überprüfen sie das ausmass um mögliche interferenzen auf einigen maschinen modellen zu vermeiden

ATTENZIONE - ATTENTION - ACHTUNG

- Per lo smontaggio degli utensili utilizzare sempre la chiave di contrasto come indicato nel manuale d'uso.
- For disassembly of the tools use always the contrast key as mentioned in the user instructions.
- Fuer das Abmontieren der Werkzeuge immer den Gegenschlüssel benutzen wie in der Bedienungsanleitung erwahnt.

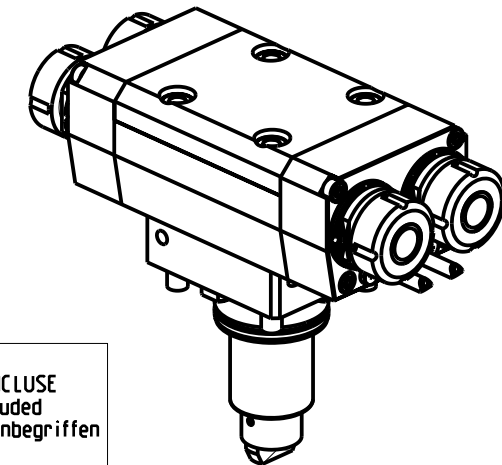
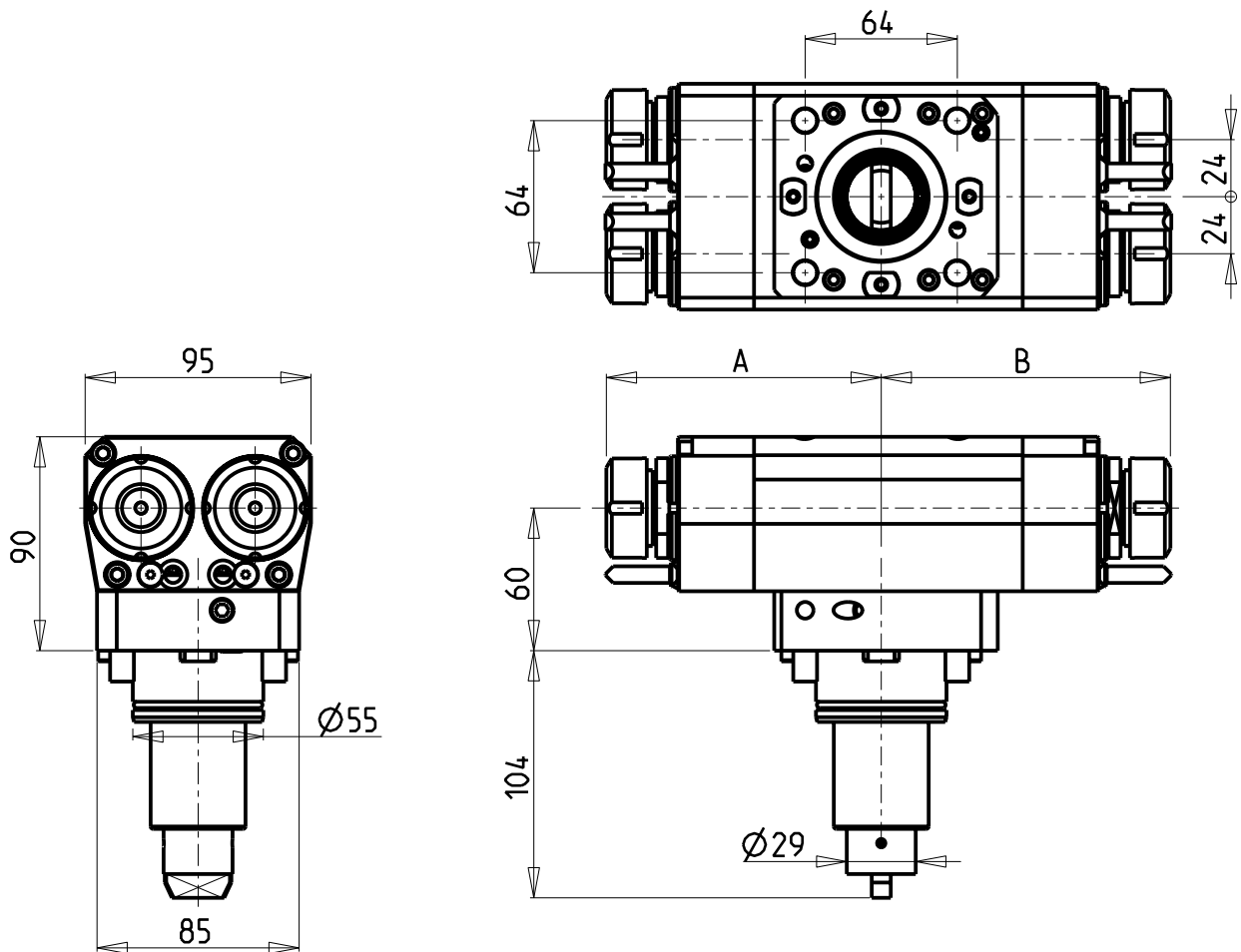

Cod. MT	Mandrino Spindle Spindel	I	RPM	Coppia Max Max Torque Max Drehmoment	Reversibile lato mandrino/contromandrino Reversible sub/main spindle side Umkehrbare Spindel-seite/ Gegenspindel-seite	N°Utensili N°Tools N°Werkzeuge	Lubrificazione est. Ext. coolant Aussehenkuehlung	A	B	CHIAVI NON INCLUSE Keys not included Schluessel nicht einbegriffen	
DW 02401416	ER16+ER16	1:1	6000	50Nm	X	2+2	X	114.7	120.7	CHUB17	CHMNER16
DW 02401425	ER25+ER25	1:1	6000	50Nm	X	2+2	X	115.6	121.6	CHUB36	CHSTER25

DOOSAN BMT 55

MOD: PUMA 1500-2000-2500M/MS/Y/SY - PUMA 2100 12ST. - PUMA 2600 16ST.

MODULO MOTORIZZATO ASSIALE 2+2 USCITE IN Y H=60mm

Axial multiple 2+2 outlet driven tool in Y H=60mm

Axial angetriebenes Mehrspindel-Werkzeug 2+2 Ausgaenge in Y H=60mm

Subject to change without notice.

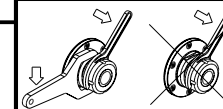

M.T. srl

Via Casino Albini 480
Tel. 0541/956034-957884
Fax 0541/956341
47842 S. GIOVANNI IN M. (RN)
e-mail: mtma@mtmarchetti.com
http://www.mtmarchetti.com

PRODUZIONE MODULI ROTANTI



PAGINA DW 0268-2-10

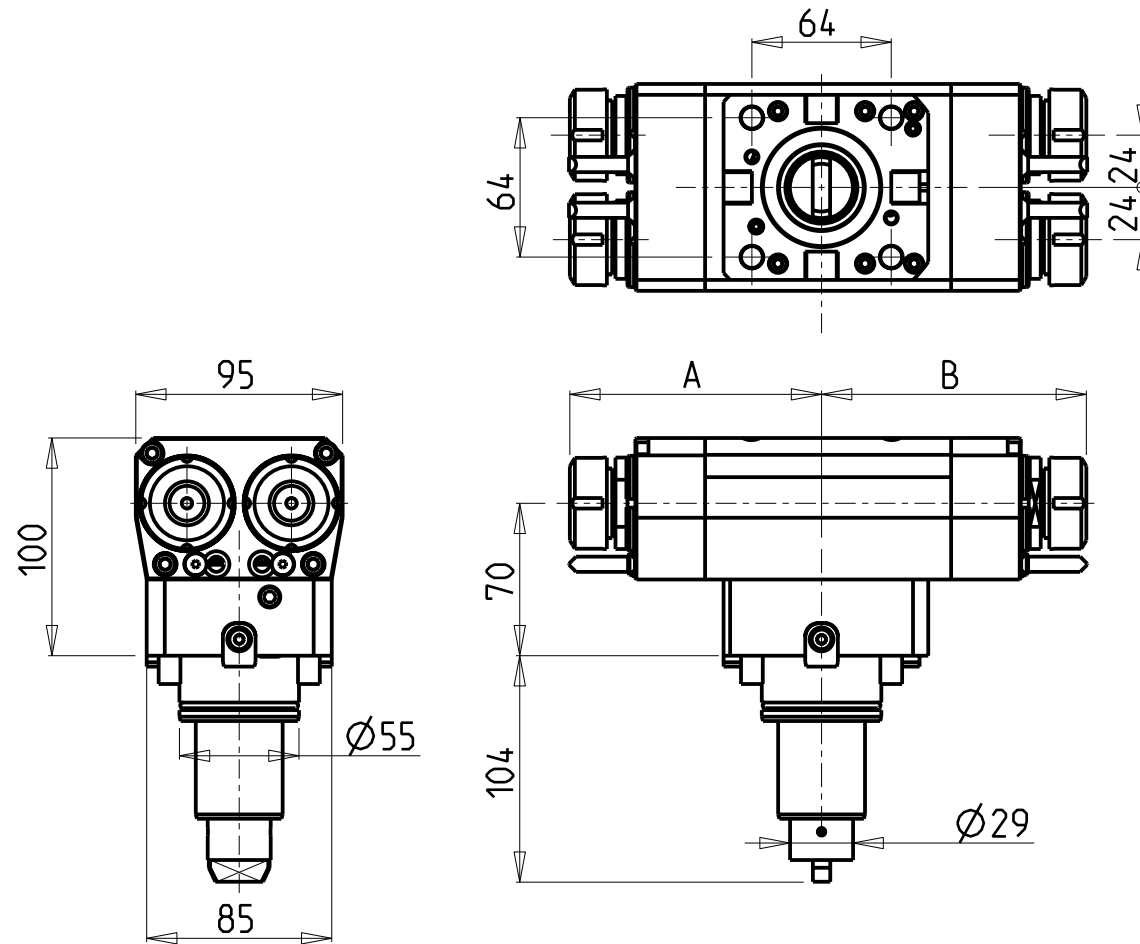

ATTENZIONE - ATTENTION - ACHTUNG

- VERIFICARE LE MISURE DI INGOMBRO PER POSSIBILE INTERFERENZA SU ALCUNI MODELLI DI MACCHINE
- Please check the overall sizes for possible interferences on some machine models
- Bitte überprüfen sie das ausmass um mögliche interferenzen auf einigen maschinen modellen zu vermeiden

ATTENZIONE - ATTENTION - ACHTUNG

- Per lo smontaggio degli utensili utilizzare sempre la chiave di contrasto come indicato nel manuale d'uso.
- For disassembly of the tools use always the contrast key as mentioned in the user instructions.
- Für das Abmontieren der Werkzeuge immer den Gegenschlüssel benutzen wie in der Bedienungsanleitung erwähnt.

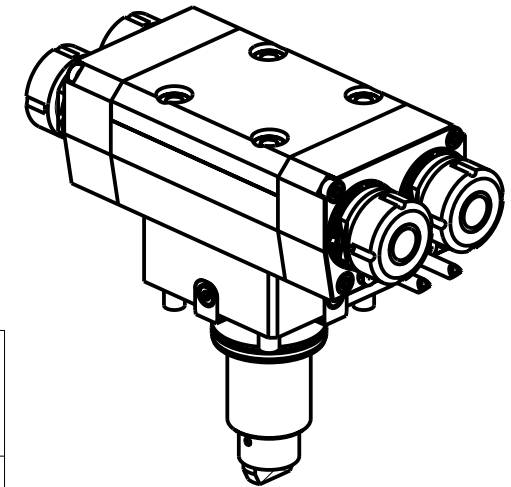

Cod. MT	Mandrino Spindle Spindel	I	RPM	Coppia Max Max Torque Max Drehmoment	Reversibile lato mandrino/contromandrino Reversible sub/main spindle side Umkehrbare Spindel-seite/Gegenspindel-seite	N°Utensili N°Tools N°Werkzeuge	Lubrificazione est. Ext. coolant Aussenkuehlung	A	B	CHIAVI NON INCLUSE Keys not included Schluessel nicht einbegriffen	
DW 02400416	ER16+ER16	1:1	6000	50Nm	X	2+2	X	114.7	120.7	CHUB17	CHMNER16
DW 02400425	ER25+ER25	1:1	6000	50Nm	X	2+2	X	115.6	121.6	CHUB36	CHSTER25

DOOSAN BMT 55

MOD: PUMA 1500-2000-2500M/MS/Y/SY - PUMA 2100 12ST. - PUMA 2600 16ST.

MODULO MOTORIZZATO ASSIALE 2+2 USCITE IN Y H=70mm

Axial multiple 2+2 outlet driven tool in Y H=70mm

Axial angetriebenes Mehrspindel-Werkzeug 2+2 Ausgaenge in Y H=70mm

Subject to change without notice.

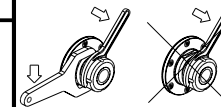

M.T. srl

Via Casino Albini 480
Tel. 0541/956034-957884
Fax 0541/956341
47842 S. GIOVANNI IN M. (RN)
e-mail: mtma@mtmarchetti.com
http://www.mtmarchetti.com

PRODUZIONE MODULI ROTANTI



PAGINA DW 0268-2-20

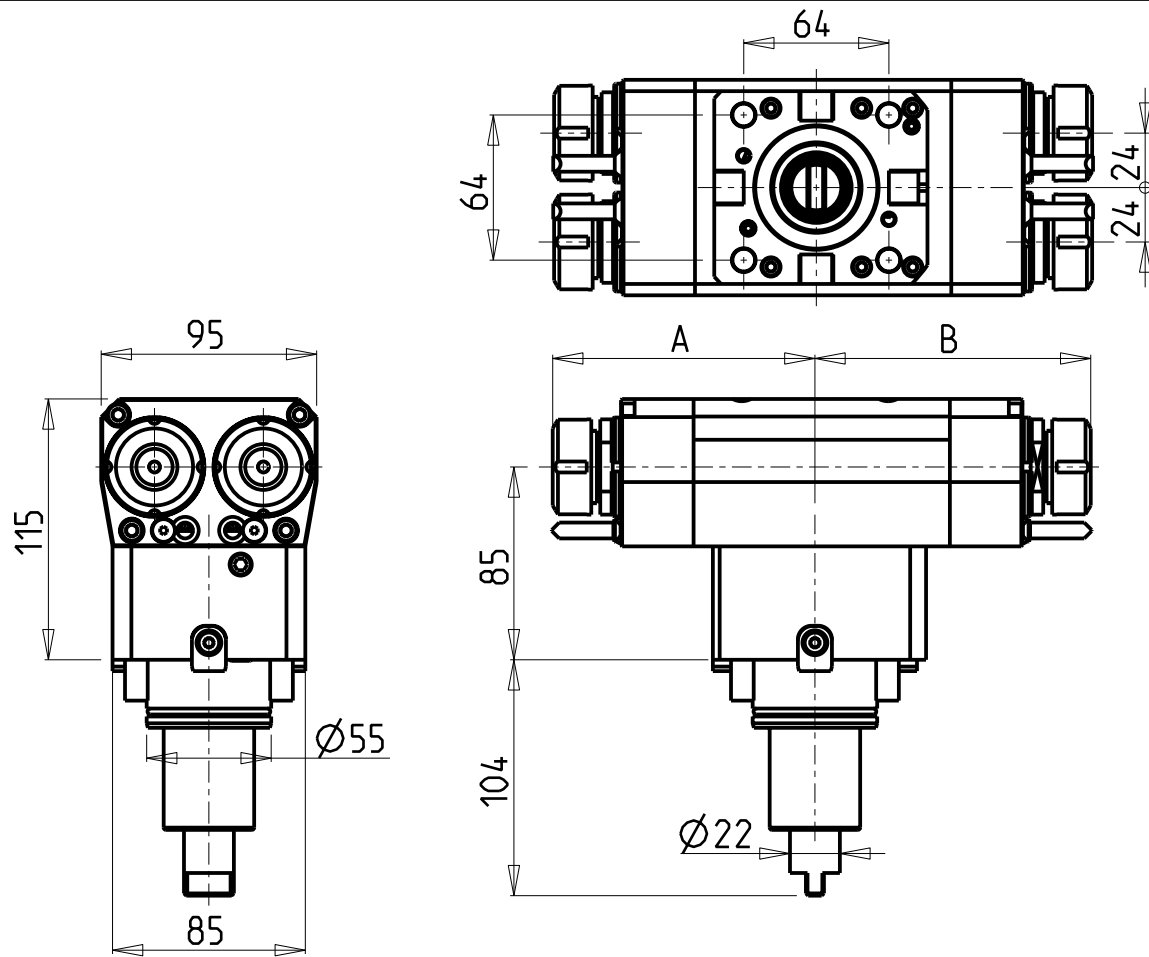

ATTENZIONE - ATTENTION - ACHTUNG

- VERIFICARE LE MISURE DI INGOMBRO PER POSSIBILE INTERFERENZA SU ALCUNI MODELLI DI MACCHINE
- Please check the overall sizes for possible interferences on some machine models
- Bitte überprüfen sie das ausmass um mögliche interferenzen auf einigen maschinen modellen zu vermeiden

ATTENZIONE - ATTENTION - ACHTUNG

- Per lo smontaggio degli utensili utilizzare sempre la chiave di contrasto come indicato nel manuale d'uso.
- For disassembly of the tools use always the contrast key as mentioned in the user instructions.
- Fuer das Abmontieren der Werkzeuge immer den Gegenschlüssel benutzen wie in der Bedienungsanleitung erwahnt.

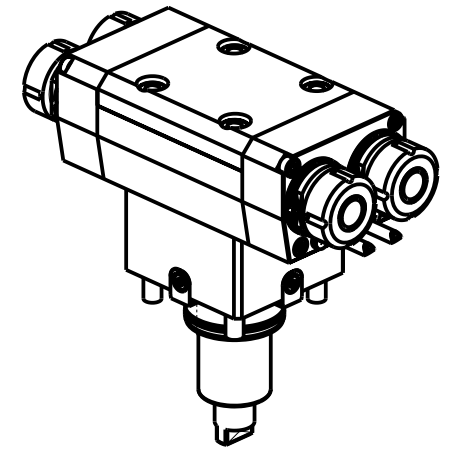

Cod. MT	Mandrino Spindle Spindel	I	RPM	Coppia Max Max Torque Max Drehmoment	Reversibile lato mandrino/contromandrino Reversible sub/main spindle side Umkehrbare Spindel-seite/ Gegenspindel-seite	N°Utensili N°Tools N°Werkzeuge	Lubrificazione est. Ext. coolant Aussehenkuehlung	A	B	CHIAVI NON INCLUSE Keys not included Schluessel nicht einbegriffen	
DW 02402416	ER16+ER16	1:1	6000	50Nm	X	2+2	X	114.7	120.7	CHUB17	CHMNER16
DW 02402425	ER25+ER25	1:1	6000	50Nm	X	2+2	X	115.6	121.6	CHUB36	CHSTER25

DOOSAN BMT 55

MOD: PUMA 1500-2000-2500M/MS/Y/SY - PUMA 2100 12ST. - PUMA TT1500-1800-2100MS/SY/SYY

MODULO MOTORIZZATO ASSIALE 2+2 USCITE IN Y H=85mm

Axial multiple 2+2 outlet driven tool in Y H=85mm

Axial angetriebenes Mehrspindel-Werkzeug 2+2 Ausgaenge in Y H=85mm

Subject to change without notice.

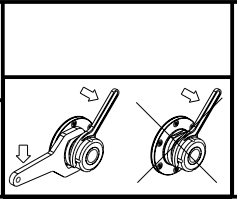

M.T. srl
 Via Casino Albini 480
 Tel. 0541/956034-957884
 Fax 0541/956341
 47842 S. GIOVANNI IN M. (RN)
 e-mail: mtma@mtmarchetti.com
 http://www.mtmarchetti.com

PRODUZIONE MODULI ROTANTI



PAGINA DW0268-2-30

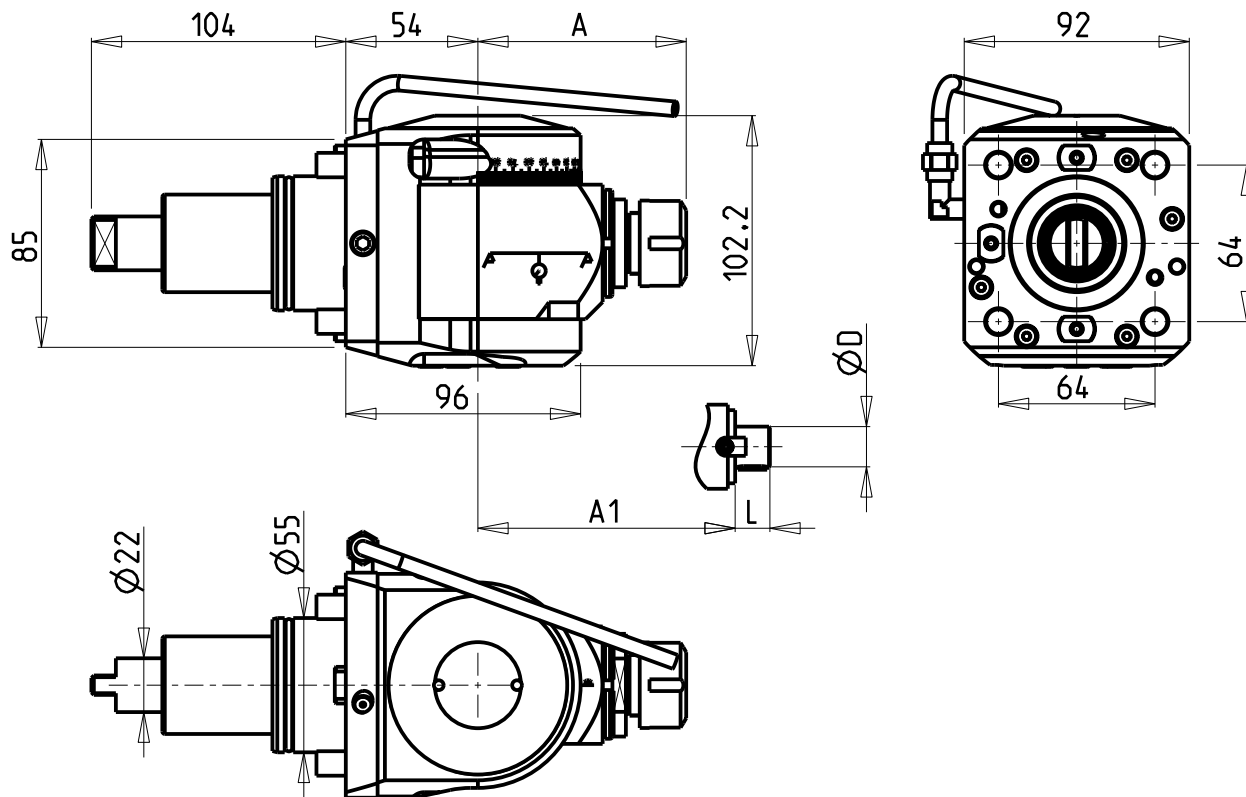

ATTENZIONE - ATTENTION - ACHTUNG

- VERIFICARE LE MISURE DI INGOMBRO PER POSSIBILE INTERFERENZA SU ALCUNI MODELLI DI MACCHINE
- Please check the overall sizes for possible interferences on some machine models
- Bitte überprüfen sie das ausmass um mögliche interferenzen auf einigen maschinen modellen zu vermeiden

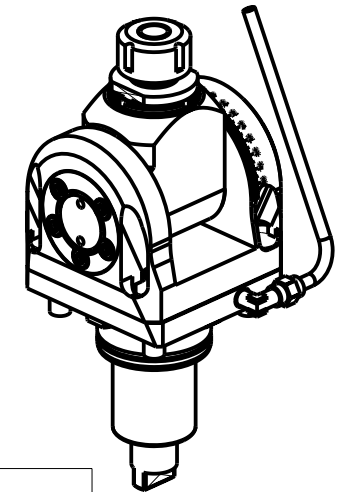

Cod. MT	Mandrino Spindle Spindel	I	RPM	Coppia Max Max Torque Max Drehmoment	Reversibile lato mandrino/contromandrino Reversible sub/main spindle side Umkehrbare Spindelseite/ Gegenspindelseite	Lubrificazione est. Ext. coolant Ausseenkuehlung	A	A1	D	L	CHIAVI INCLUSE Keys included Schluessel inbegriffen		
											CH_VTCROCE_M08	CHUB36	CHESL08
DW 01910120	ER20	1:1	6000	40Nm	X	X	85.16	-	-	-	CHSTER20	CHUB36	CHESL08
DW 01910125	ER25	1:1	6000	40Nm	X	X	86.16	-	-	-	CHSTER25	CHUB36	CHESL08
DW 01910516	Ø16x17	1:1	6000	40Nm	X	X	-	65	16	17	CH_VTCROCE_M08	CHUB36	CHESL08
DW 01910522	Ø22x19	1:1	6000	40Nm	X	X	-	66	22	19	CH_VTCROCE_M10	CHUB36	CHESL08
DW 01910519	Ø3/4"x3/4"	1:1	6000	40Nm	X	X	-	65	3/4"	3/4"	CH_VTCROCE_M08	CHUB36	CHESL08

DOOSAN BMT 55

MOD: PUMA 230-240M/MS-280LM - PUMA 1500-2000-2500M/MS/Y/SY - LINX 300 M - PUMA 2100 12ST. - PUMA 2600 16ST.
PUMA TW 2600 10ST. - PUMA TT1500-1800-2100MS/SY/SYY - TL2000-2500 (M) - PUMA GT2100-2600 M - PUMA H250TM - PUMA QL200HM

MODULO MOTORIZZATO ORIENTABILE ±90° H=54mm

±90° adjustable angle driven tool H=54mm

Angetriebenes Werkzeug schwenkbar ±90° H=54mm

Subject to change without notice.

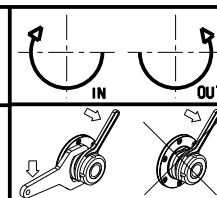

M.T. srl

Via Casino Albini 480
Tel. 0541/956034-957884
Fax 0541/956341
47842 S. GIOVANNI IN M. (RN)
e-mail: mtma@mtmarchetti.com
http://www.mtmarchetti.com

PRODUZIONE MODULI ROTANTI



PAGINA DW0333-2-00

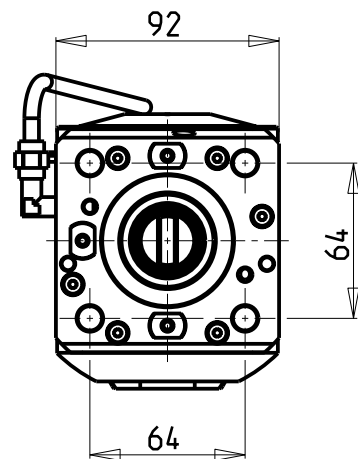
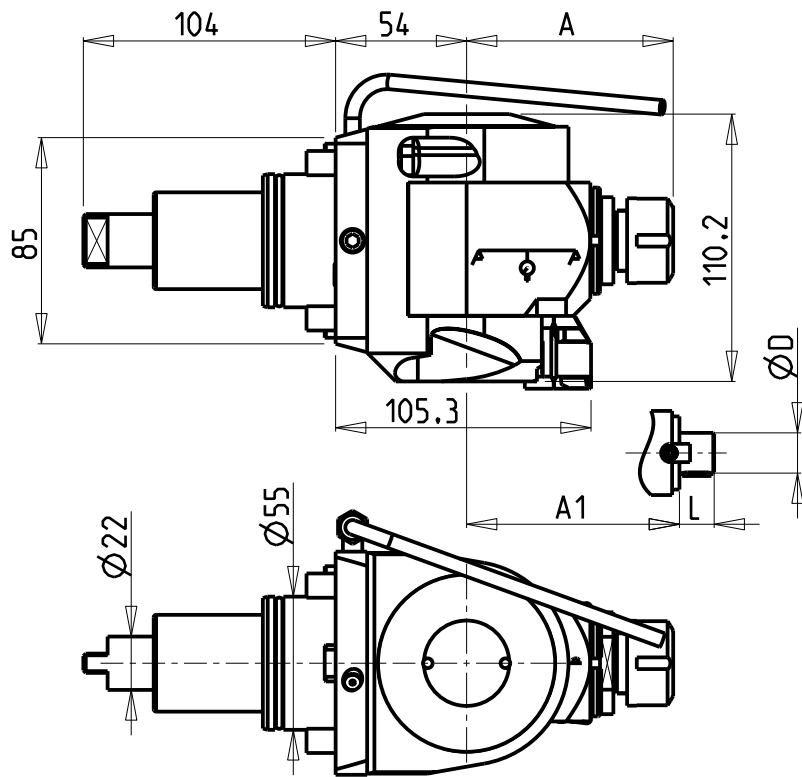

ATTENZIONE - ATTENTION - ACHTUNG

- VERIFICARE LE MISURE DI INGOMBRO PER POSSIBILE INTERFERENZA SU ALCUNI MODELLI DI MACCHINE
- Please check the overall sizes for possible interferences on some machine models
- Bitte überprüfen sie das ausmass um mögliche interferenzen auf einigen maschinen modellen zu vermeiden

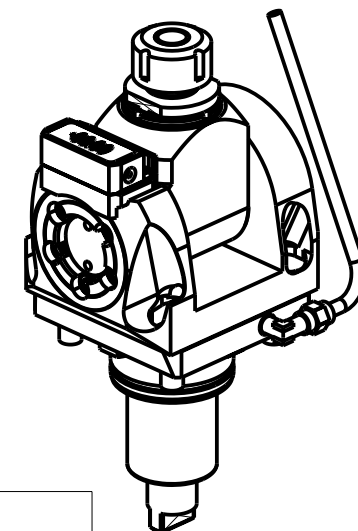

Cod. MT	Mandrino Spindle Spindel	I	RPM	Coppia Max Max Torque Max Drehmoment	Reversibile lato mandrino/contromandrino Reversible sub/main spindle side Umkehrbare Spindelseite/ Gegenspindelsteite	Lubrificazione est. Ext. coolant Aussehenkuehlung	A	A1	D	L	CHIAVI INCLUSE Keys included Schlüssel inbegriffen		
											CH_VTCROCE_M08	CHUB36	CHESL08
DW 0184 0120	ER20	1:1	6000	40Nm	X	X	85.16	-	-	-	CHSTER20	CHUB36	CHESL08
DW 0184 0125	ER25	1:1	6000	40Nm	X	X	86.16	-	-	-	CHSTER25	CHUB36	CHESL08
DW 0184 0516	Ø16x17	1:1	6000	40Nm	X	X	-	65	16	17	CH_VTCROCE_M08	CHUB36	CHESL08
DW 0184 0522	Ø22x19	1:1	6000	40Nm	X	X	-	66	22	19	CH_VTCROCE_M10	CHUB36	CHESL08
DW 0184 0519	Ø3/4"x3/4"	1:1	6000	40Nm	X	X	-	65	3/4"	3/4"	CH_VTCROCE_M08	CHUB36	CHESL08

DOOSAN BMT 55

MOD: PUMA 230-240M/MS-280LM - PUMA 1500-2000-2500M/MS/Y/SY - LINX 300 M - PUMA 2100 12ST. - PUMA 2600 16ST.
PUMA TW 2600 10ST. - PUMA TT1500-1800-2100MS/SY/SYY - TL2000-2500 (M) - PUMA GT2100-2600 M - PUMA H250TM - PUMA QL200HM

MODULO MOTORIZZATO ORIENTABILE ±90° CON NONIO DIGITALE H=54mm
±90° adjustable angle driven tool with digital display H=54mm
Angetriebenes Werkzeug schwenkbar ±90° mit digital display H=54mm

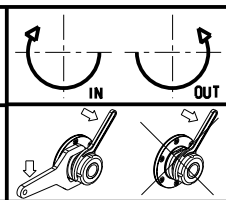

M.T. srl

Via Casino Albini 480
Tel. 0541/956034-957884
Fax 0541/956341
47842 S. GIOVANNI IN M. (RN)
e-mail: mtma@mtmarchetti.com
http://www.mtmarchetti.com

PRODUZIONE MODULI ROTANTI



PAGINA DW0333-2-01

Subject to change without notice.

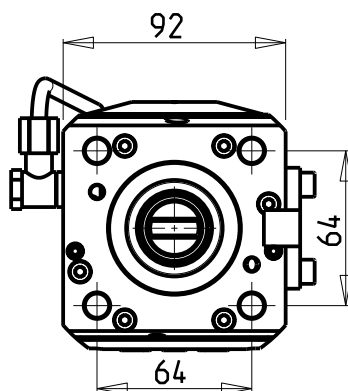
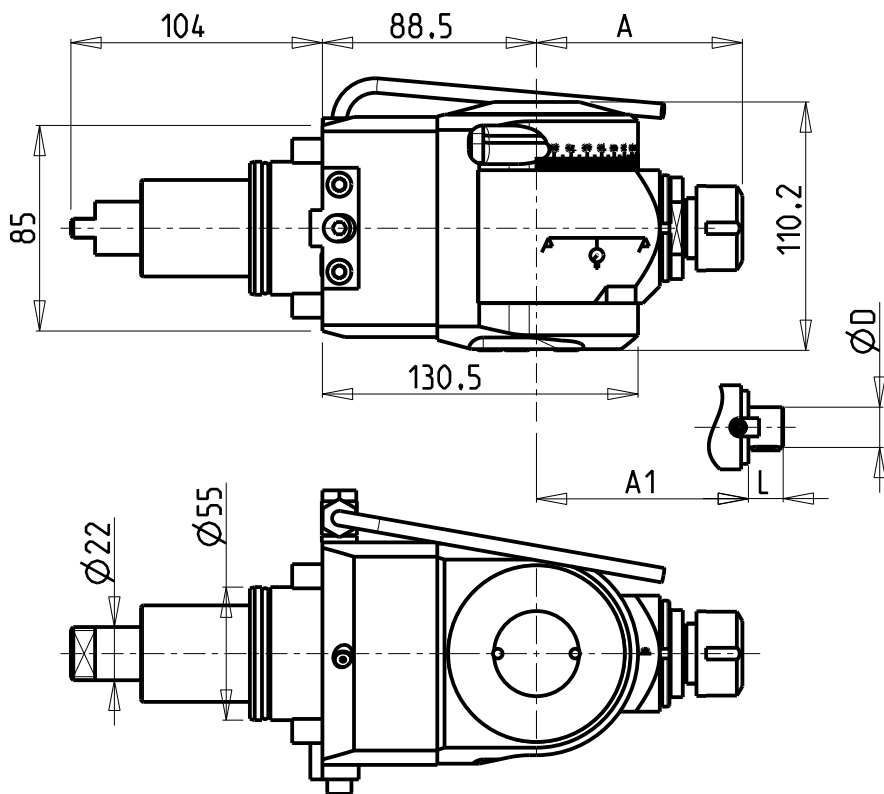

ATTENZIONE - ATTENTION - ACHTUNG

- VERIFICARE LE MISURE DI INGOMBRO PER POSSIBILE INTERFERENZA SU ALCUNI MODELLI DI MACCHINE
- Please check the overall sizes for possible interferences on some machine models
- Bitte überprüfen sie das ausmass um mögliche interferenzen auf einigen maschinen modellen zu vermeiden

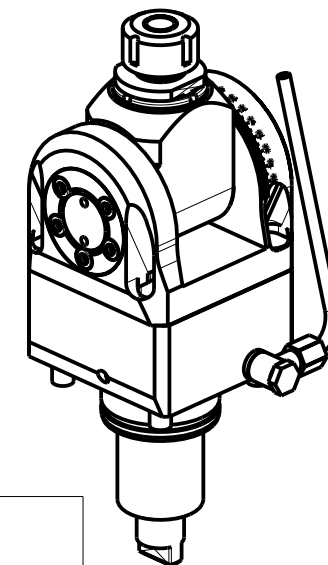

Cod. MT	Mandrino Spindle Spindel	I	RPM	Coppia Max Max Torque Max Drehmoment	Reversibile lato mandrino/contromandrino Reversible sub/main spindle side Umkehrbare Spindel-seite/ Gegenspindel-seite	Lubrificazione est. Ext. coolant Aussehenkuehlung	A	A1	D	L	CHIAVI INCLUSE Keys included Schluessel inbegriffen		
											CH_VTCROCE_M08	CHUB36	CHESL08
DW 01970120	ER20	1:1	6000	40Nm	X	X	85.16	-	-	-	CHSTER20	CHUB36	CHESL08
DW 01970125	ER25	1:1	6000	40Nm	X	X	86.16	-	-	-	CHSTER25	CHUB36	CHESL08
DW 01970516	Ø16x17	1:1	6000	40Nm	X	X	-	65	16	17	CH_VTCROCE_M08	CHUB36	CHESL08
DW 01970522	Ø22x19	1:1	6000	40Nm	X	X	-	66	22	19	CH_VTCROCE_M10	CHUB36	CHESL08
DW 01970519	Ø3/4"x3/4"	1:1	6000	40Nm	X	X	-	65	3/4"	3/4"	CH_VTCROCE_M08	CHUB36	CHESL08

DOOSAN BMT 55

MOD: MX1600/2100ST 12ST. - PUMA TW 2600 10ST.

MODULO MOTORIZZATO ORIENTABILE ±90° H=88.5mm

±90° adjustable angle driven tool H=88.5mm

Angetriebenes Werkzeug schwenkbar ±90° H=88.5mm

Subject to change without notice.

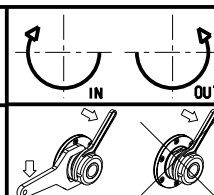

M.T. srl

Via Casino Albini 480
Tel. 0541/956034-957884
Fax 0541/956341
47842 S. GIOVANNI IN M. (RN)
e-mail: mtma@mtmarchetti.com
http://www.mtmarchetti.com

PRODUZIONE MODULI ROTANTI



PAGINA DW0333-2-10

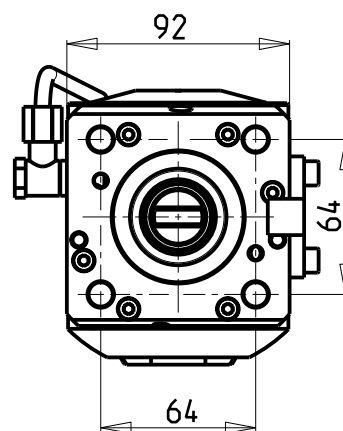
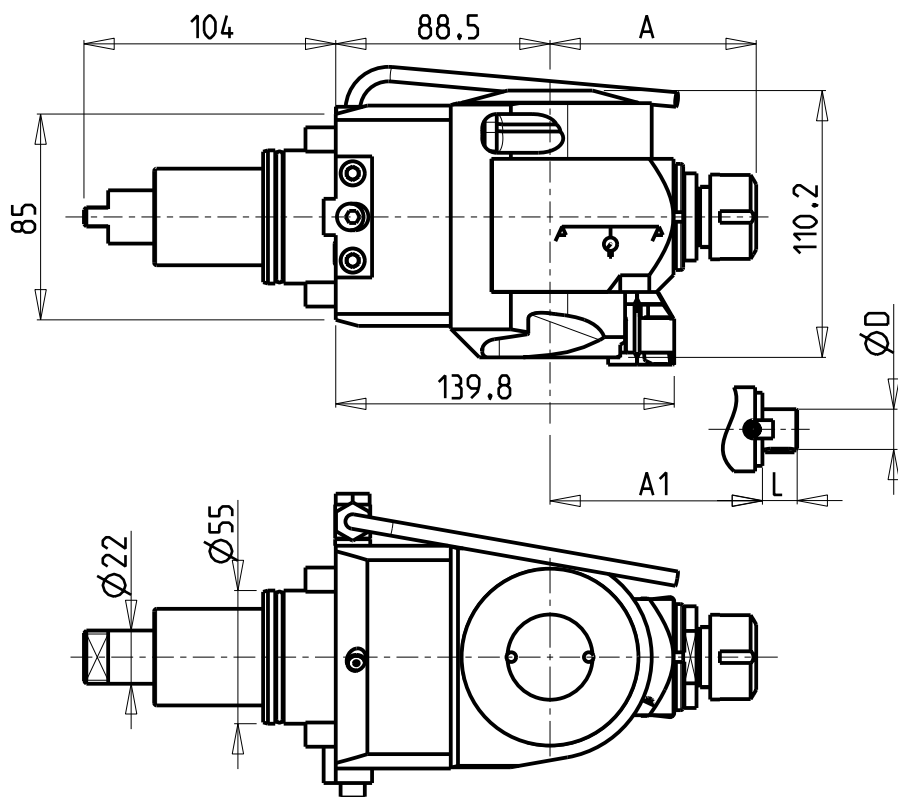

ATTENZIONE - ATTENTION - ACHTUNG

- VERIFICARE LE MISURE DI INGOMBRO PER POSSIBILE INTERFERENZA SU ALCUNI MODELLI DI MACCHINE
- Please check the overall sizes for possible interferences on some machine models
- Bitte überprüfen sie das ausmass um mögliche interferenzen auf einigen maschinen modellen zu vermeiden

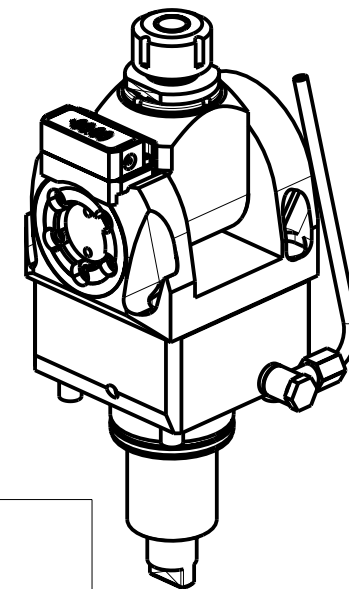

Cod. MT	Mandrino Spindle Spindel	I	RPM	Coppia Max Max Torque Max Drehmoment	Reversibile lato mandrino/contromandrino Reversible sub/main spindle side Umkehrbare Spindelseite/ Gegenspindelseite	Lubrificazione est. Ext. coolant Aussehenkuehlung	A	A1	D	L	CHIAVI INCLUSE Keys included Schlüssel inbegriffen		
											CH_VTCROCE_M08	CHUB36	CHESL08
DW 01960120	ER20	1:1	6000	40Nm	X	X	85.16	-	-	-	CHSTER20	CHUB36	CHESL08
DW 01960125	ER25	1:1	6000	40Nm	X	X	86.16	-	-	-	CHSTER25	CHUB36	CHESL08
DW 01960516	Ø16x17	1:1	6000	40Nm	X	X	-	65	16	17	CH_VTCROCE_M08	CHUB36	CHESL08
DW 01960522	Ø22x19	1:1	6000	40Nm	X	X	-	66	22	19	CH_VTCROCE_M10	CHUB36	CHESL08
DW 01960519	Ø3/4"x3/4"	1:1	6000	40Nm	X	X	-	65	3/4"	3/4"	CH_VTCROCE_M08	CHUB36	CHESL08

DOOSAN BMT 55

MOD: MX1600/2100ST 12ST. - PUMA TW 2600 10ST.

MODULO MOTORIZZATO ORIENTABILE ±90° CON NONIO DIGITALE H=88.5mm

±90° adjustable angle driven tool with digital display H=88.5mm

Angetriebenes Werkzeug schwenkbar ±90° mit digital display H=88.5mm

Subject to change without notice.

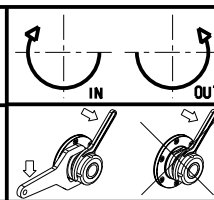

M.T. srl

Via Casino Albini 480
Tel. 0541/956034-957884
Fax 0541/956341
47842 S. GIOVANNI IN M. (RN)
e-mail: mtma@mtmarchetti.com
http://www.mtmarchetti.com

PRODUZIONE MODULI ROTANTI



PAGINA DW 0333-2-11

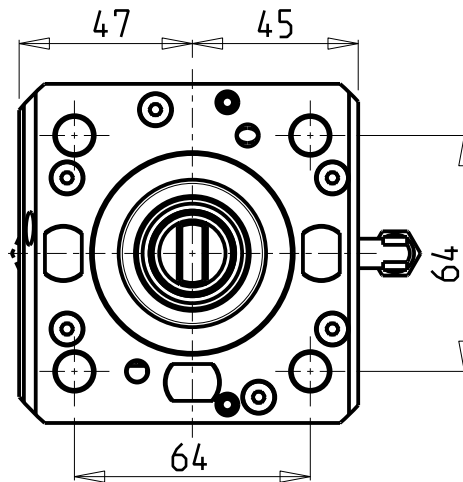
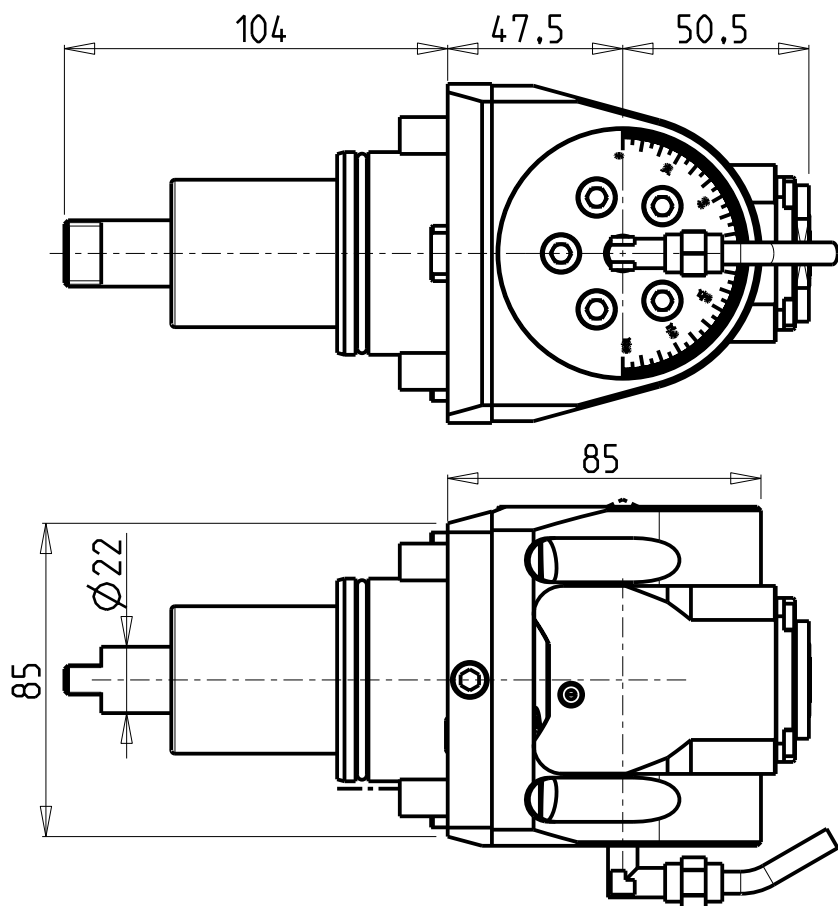

ATTENZIONE - ATTENTION - ACHTUNG

-Su macchine PUMA 280. PUMA TT1500-TT1800-TT2100 serie non arriva in centro mandrino.

-On machines PUMA 280. PUMA TT1500-TT1800-TT2100 series tool does not get to the centre of the spindle axis.

-Auf Maschinen PUMA 280. PUMA TT1500-TT1800-TT2100 serie erreicht das Werkzeug nicht die Mitte der Werkzeug-Achse.

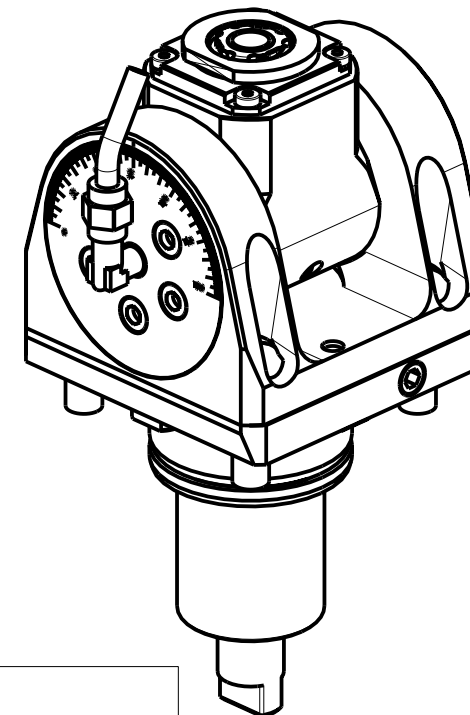

Cod. MT	Mandrino Spindle Spindel	I	RPM	Coppia Max Max Torque Max Drehmoment	Reversibile lato mandrino/contromandrino Reversible sub/main spindle side Umkehrbare Spindelsete/Gegenspindelsete	Lubrificazione int. Coolant through Innenkuehlung	Lubrificazione est. Ext. coolant Aussenkuehlung	CHIAVI INCLUSE Keys included Schluessel inbegriffen			
								CHUB22	CHUB36	CHTAER20ZC	CHESLO7
DW00660120	ERA20	1:1	6000	30Nm	X	-	X	CHUB22	CHUB36	CHTAER20ZC	CHESLO7
DW00660220	ERA20	1:1	6000	30Nm	X	P=70bar	X	CHUB22	CHUB36	CHTAER20ZC	CHESLO7

DOOSAN BMT 55

MOD: PUMA 230-240M/MS-280LM - PUMA 1500-2000-2500M/MS/Y/SY - LINX 300 M - PUMA 2100 12ST. - PUMA 2600 16ST.
PUMA TT1500-1800-2100MS/SY/SYY - TL2000-2500 (M) - PUMA GT2100-2600 M - PUMA H250TM - PUMA QL200HM

MODULO MOTORIZZATO ORIENTABILE ±90° H=47.5mm

±90° adjustable angle driven tool H=47.5mm

Angetriebenes Werkzeug schwenkbar ±90° H=47.5mm

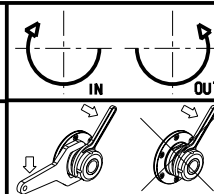

M.T. srl

Via Casino Albini 480
Tel. 0541/956034-957884
Fax 0541/956341

47842 S. GIOVANNI IN M. (RN)
e-mail: mtma@mtmarchetti.com
http://www.mtmarchetti.com

PRODUZIONE MODULI ROTANTI



PAGINA DW0335-2-00

Subject to change without notice.

04/2020

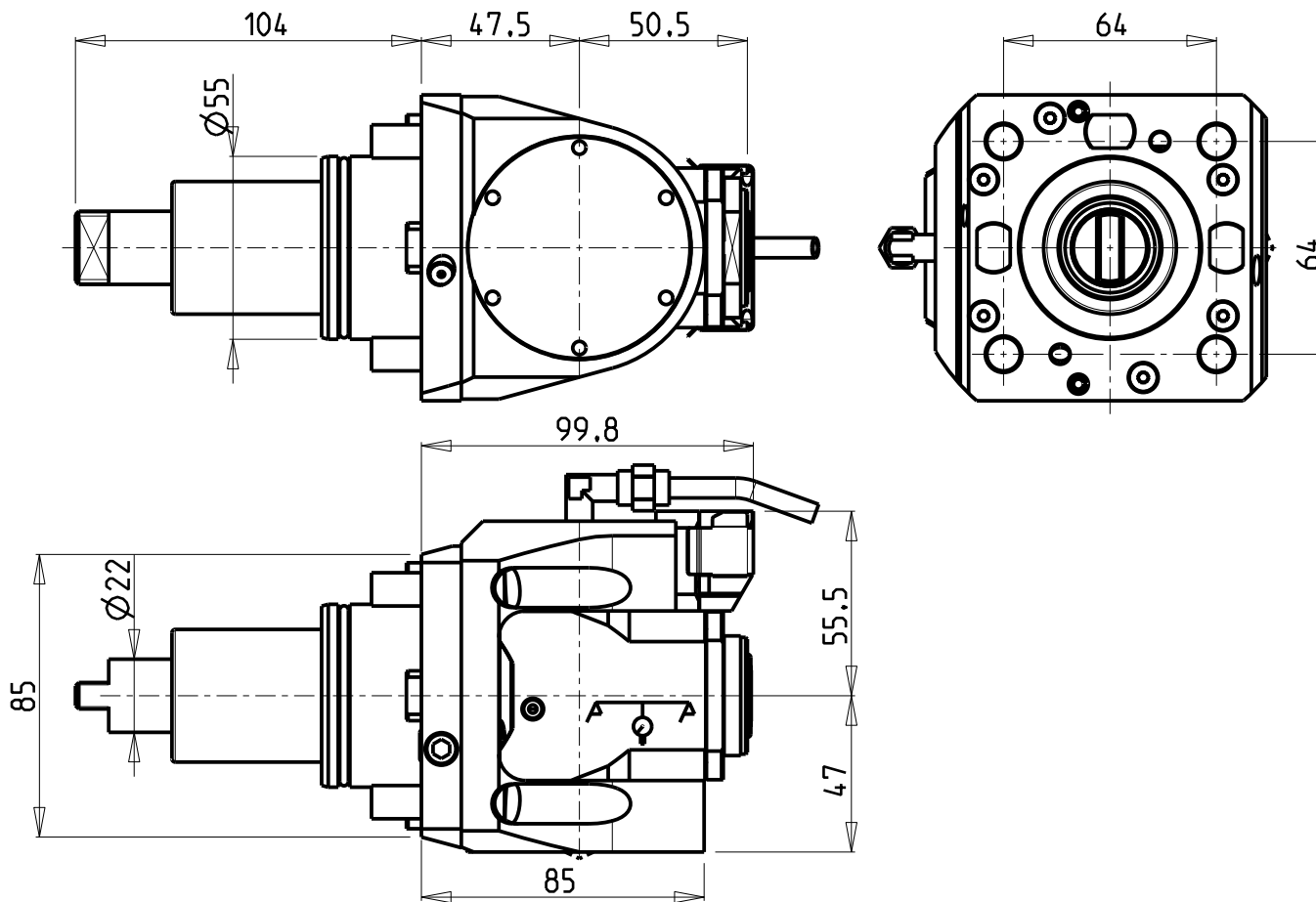

ATTENZIONE - ATTENTION - ACHTUNG

- Su macchine PUMA 280. PUMA TT1500-TT1800-TT2100 serie non arriva in centro mandrino.
- On machines PUMA 280. PUMA TT1500-TT1800-TT2100 series tool does not get to the centre of the spindle axis.
- Auf Maschinen PUMA 280. PUMA TT1500-TT1800-TT2100 serie erreicht das Werkzeug nicht die Mitte der Werkzeug-Achse.

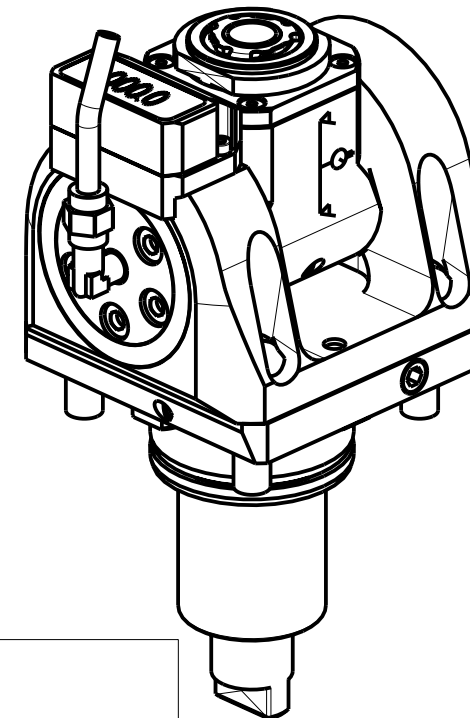

Cod. MT	Mandrino Spindle Spindel	I	RPM	Coppia Max Max Torque Max Drehmoment	Reversibile lato mandrino/contromandrino Reversible sub/main spindle side Umkehrbare Spindelsete/ Gegenspindelsete	Lubrificazione int. Coolant through Innenkuehlung	Lubrificazione est. Ext. coolant Aussenkuehlung	CHIAVI INCLUSE Keys included Schluessel inbegriffen			
								CHUB22	CHUB36	CHTAER20ZC	CHESLO7
DW00665120	ERA20	1:1	6000	30Nm	X	-	X	CHUB22	CHUB36	CHTAER20ZC	CHESLO7
DW00665220	ERA20	1:1	6000	30Nm	X	P=70bar	X	CHUB22	CHUB36	CHTAER20ZC	CHESLO7

DOOSAN BMT 55

MOD: PUMA 230-240M/MS-280LM - PUMA 1500-2000-2500M/MS/Y/SY - LINX 300 M - PUMA 2100 12ST. - PUMA 2600 16ST.
PUMA TT1500-1800-2100MS/SY/SYY - TL2000-2500 (M) - PUMA GT2100-2600 M - PUMA H250TM - PUMA QL200HM

MODULO MOTORIZZATO ORIENTABILE ±90° CON NONIO DIGITALE H=47.5mm

±90° adjustable angle driven tool with digital display H=47.5mm

Angetriebenes Werkzeug schwenkbar ±90° mit digital display H=47.5mm

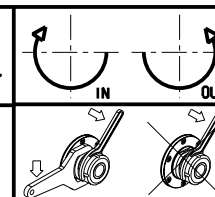

M.T. srl

Via Casino Albini 480
Tel. 0541/956034-957884
Fax 0541/956341
47842 S. GIOVANNI IN M. (RN)
e-mail: mtma@mtmarchetti.com
http://www.mtmarchetti.com

PRODUZIONE MODULI ROTANTI



PAGINA DW0335-2-01

Subject to change without notice.

04/2020

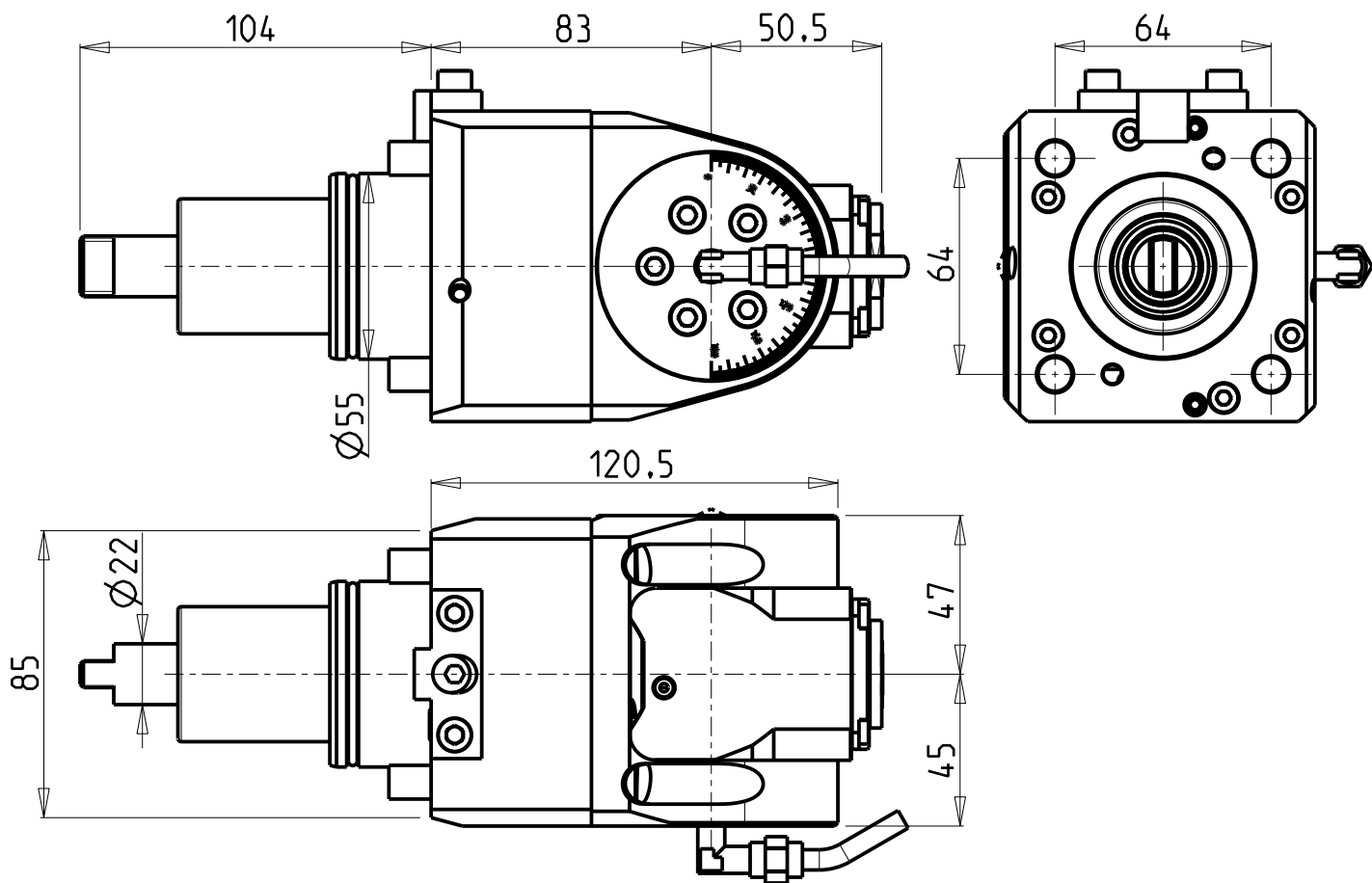

ATTENZIONE - ATTENTION - ACHTUNG

- VERIFICARE LE MISURE DI INGOMBRO PER POSSIBILE INTERFERENZA SU ALCUNI MODELLI DI MACCHINE
- Please check the overall sizes for possible interferences on some machine models
- Bitte überprüfen sie das ausmass um mögliche interferenzen auf einigen maschinen modellen zu vermeiden

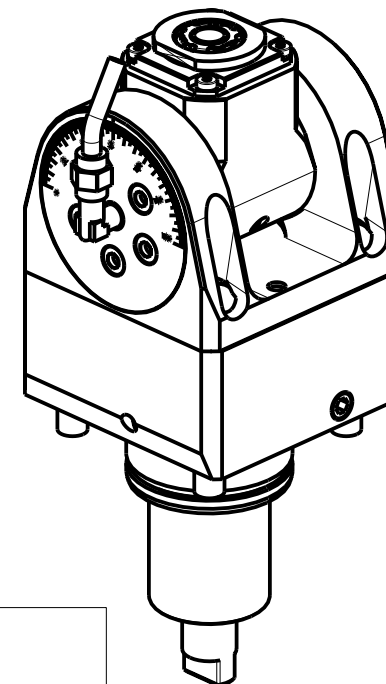

Cod. MT	Mandrino Spindle Spindel	I	RPM	Coppia Max Max Torque Max Drehmoment	Reversibile lato mandrino/contromandrino Reversible sub/main spindle side Umkehrbare Spindel-seite/ Gegenspindel-seite	Lubrificazione int. Coolant through Innenkuehlung	Lubrificazione est. Ext. coolant Aussenkuehlung	CHIAVI INCLUSE Keys included Schluessel inbegriffen			
								CHUB22	CHUB36	CHTAER20ZC	CHESLO8
DW 00661120	ERA20	1:1	6000	30Nm	X	-	X	CHUB22	CHUB36	CHTAER20ZC	CHESLO8
DW 00661220	ERA20	1:1	6000	30Nm	X	P=70bar	X	CHUB22	CHUB36	CHTAER20ZC	CHESLO8

DOOSAN BMT 55

MOD: PUMA 230-240M/MS-280LM - PUMA 1500-2000-2500M/MS/Y/SY - LINX 300 M - PUMA 2100 12ST. - PUMA H250TM
 PUMA TW2600 10ST. - PUMA TT1500-1800-2100MS/SY/SYY - TL2000-2500 (M) - PUMA GT2100-2600 M - PUMA QL200HM

MODULO MOTORIZZATO ORIENTABILE ±90° H=83mm

±90° adjustable angle driven tool H=83mm

Angetriebenes Werkzeug schwenkbar ±90° H=83mm

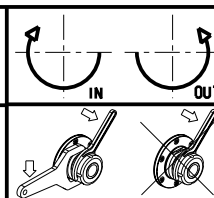

M.T. srl

Via Casino Albini 480
 Tel. 0541/956034-957884
 Fax 0541/956341
 47842 S. GIOVANNI IN M. (RN)
 e-mail: mtma@mtmarchetti.com
 http://www.mtmarchetti.com

PRODUZIONE MODULI ROTANTI



PAGINA DW0335-2-10

Subject to change without notice.

04/2020

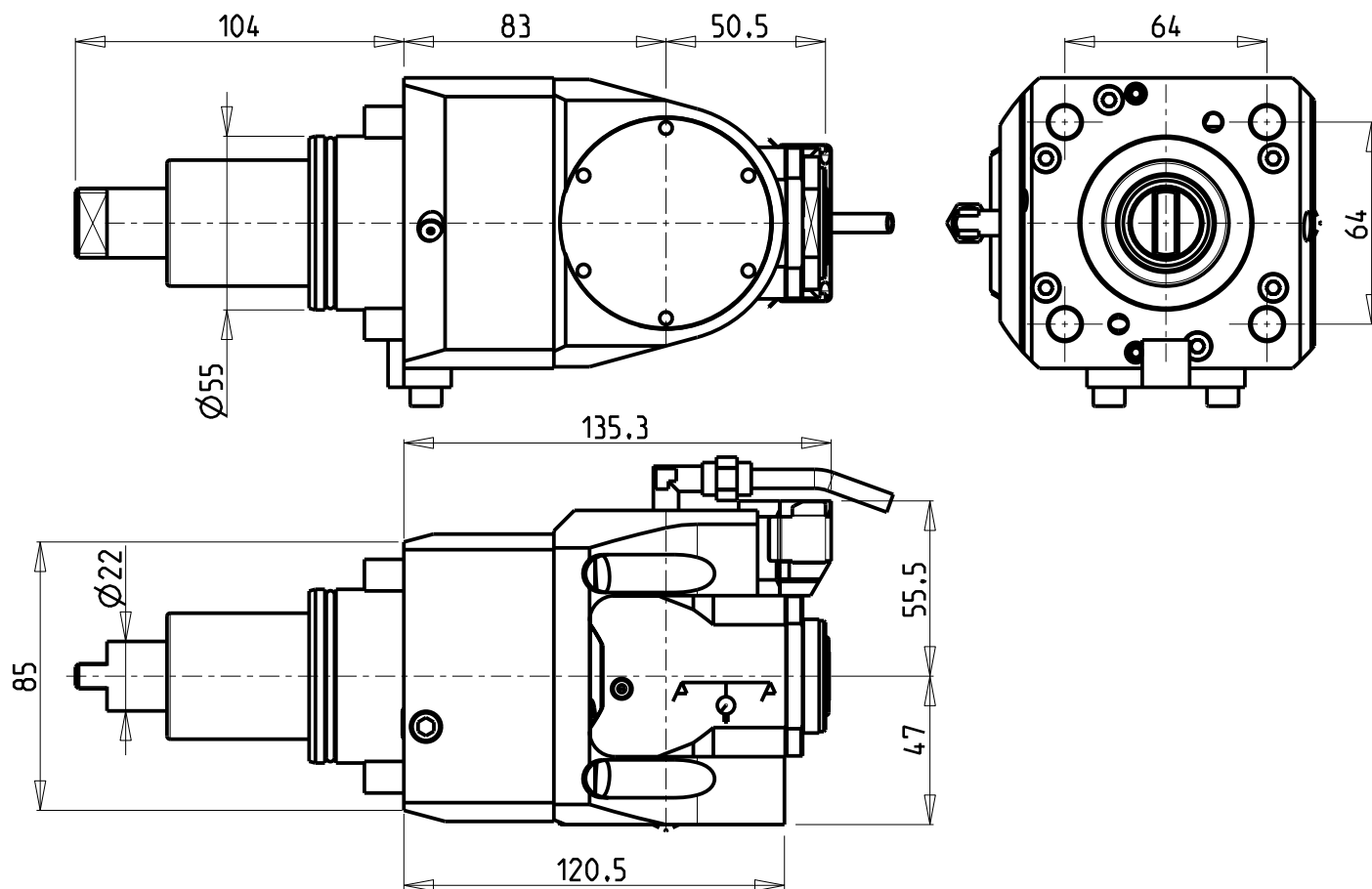

ATTENZIONE - ATTENTION - ACHTUNG

- VERIFICARE LE MISURE DI INGOMBRO PER POSSIBILE INTERFERENZA SU ALCUNI MODELLI DI MACCHINE
- Please check the overall sizes for possible interferences on some machine models
- Bitte überprüfen sie das ausmass um mögliche interferenzen auf einigen maschinen modellen zu vermeiden

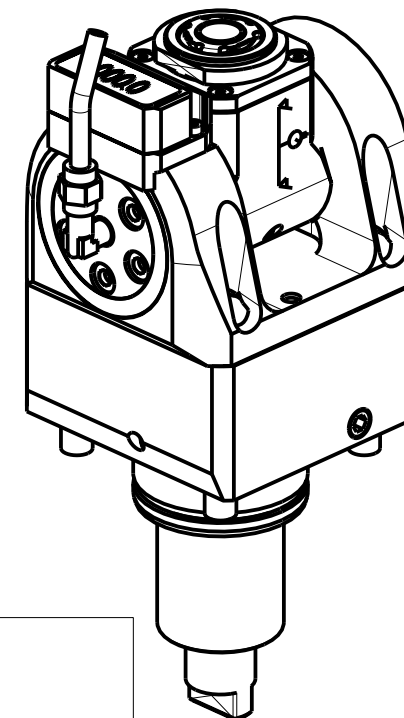

Cod. MT	Mandrino Spindle Spindel	I	RPM	Coppia Max Max Torque Max Drehmoment	Reversibile lato mandrino/contromandrino Reversible sub/main spindle side Umkehrbare Spindelsete/Gegenspindelsete	Lubrificazione int. Coolant through Innenkuehlung	Lubrificazione est. Ext. coolant Aussenkuehlung	CHIAVI INCLUSE Keys included Schluessel inbegriffen			
								CHUB22	CHUB36	CHTAER20ZC	CHESLO8
DW00666120	ERA20	1:1	6000	30Nm	X	-	X	CHUB22	CHUB36	CHTAER20ZC	CHESLO8
DW00666220	ERA20	1:1	6000	30Nm	X	P=70bar	X	CHUB22	CHUB36	CHTAER20ZC	CHESLO8

DOOSAN BMT 55

MOD: PUMA 230-240M/MS-280LM - PUMA 1500-2000-2500M/MS/Y/SY - LINX 300 M - PUMA 2100 12ST.
PUMA TW2600 10ST. - TL2000-2500 (M) - PUMA GT2100-2600 M

MODULO MOTORIZZATO ORIENTABILE ±90° CON NONIO DIGITALE H=83mm

±90° adjustable angle driven tool with digital display H=83mm

Angetriebenes Werkzeug schwenkbar ±90° mit digital display H=83mm

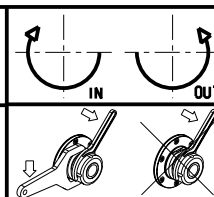

M.T. srl

Via Casino Albini 480
Tel. 0541/956034-957884
Fax 0541/956341
47842 S. GIOVANNI IN M. (RN)
e-mail: mtma@mtmarchetti.com
http://www.mtmarchetti.com

PRODUZIONE MODULI ROTANTI



PAGINA DW0335-2-11

Subject to change without notice.

04/2020

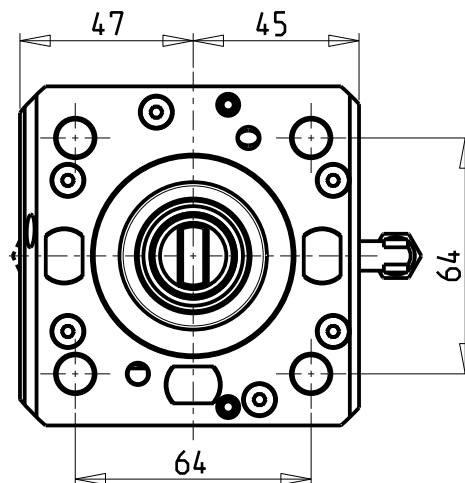
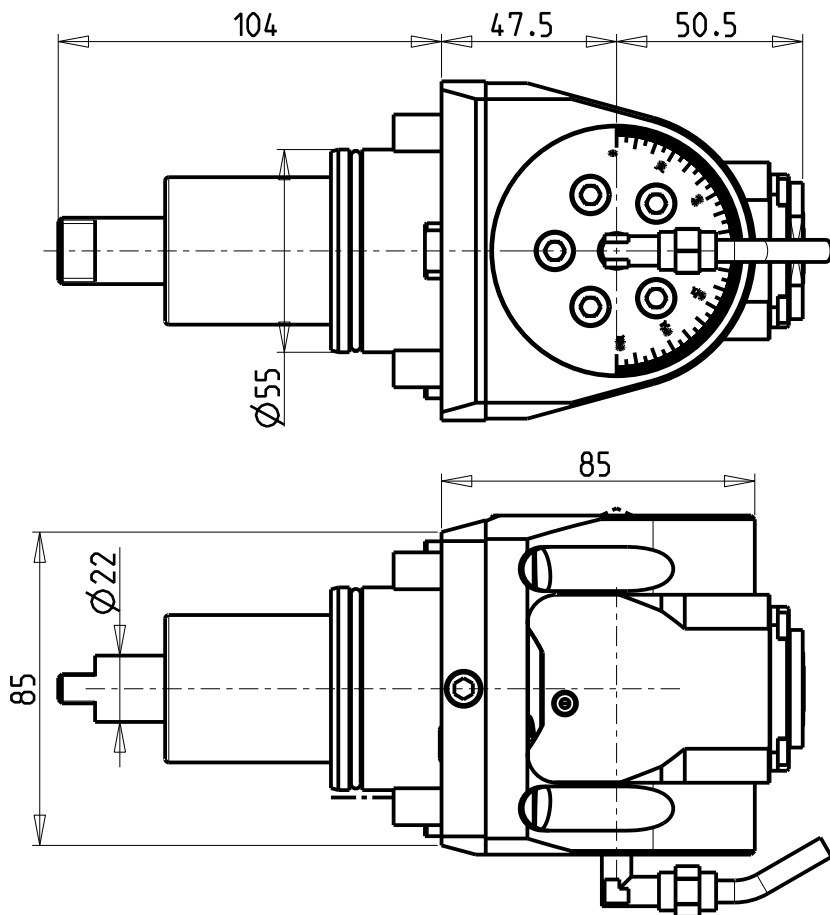

ATTENZIONE - ATTENTION - ACHTUNG

-Su macchine PUMA 280. PUMA TT1500-TT1800-TT2100 serie non arriva in centro mandrino.

-On machines PUMA 280. PUMA TT1500-TT1800-TT2100 series tool does not get to the centre of the spindle axis.

-Auf Maschinen PUMA 280. PUMA TT1500-TT1800-TT2100 serie erreicht das Werkzeug nicht die Mitte der Werkzeug-Achse.

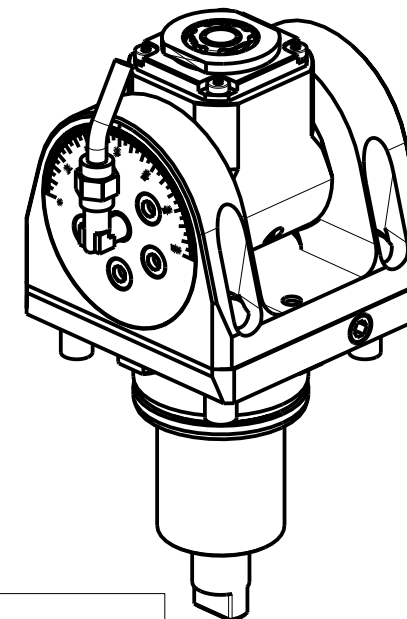

Cod. MT	Mandrino Spindle Spindel	i	RPM	Coppia Max Max Torque Max Drehmoment	Reversibile lato mandrino/contromandrino	Lubrificazione int. Coolant through Innenkuehlung	Lubrificazione est. Ext. coolant Aussenkuehlung	CHIAVI INCLUSE Keys included Schluessel inbegriffen			
					Reversible sub/main spindle side Umkehrbare Spindelsete/Gegenspindelsete						
DW00660316	ERA16	1:2	12000	8Nm	X	-	X	CHUB19_SP3	CHUB32	CHTAER16ZC	CHESL07
DW00660416	ERA16	1:2	12000	8Nm	X	P=70bar	X	CHUB19_SP3	CHUB32	CHTAER16ZC	CHESL07

DOOSAN BMT 55

MOD: PUMA 230-240M/MS-280LM - PUMA 1500-2000-2500M/MS/Y/SY - LINX 300 M - PUMA 2100 12ST. - PUMA 2600 16ST.
PUMA TT1500-1800-2100MS/SY/SYY - TL2000-2500 (M) - PUMA GT2100-2600 M - PUMA H250TM - PUMA QL200HM

MODULO MOTORIZZATO ORIENTABILE +/-90° MOLTIPLICATO I=1:2 H=47.5mm

+/-90° adjustable angle driven tool geared-up I=1:2 H=47.5mm

Angetriebenes Werkzeug schwenkbar +/-90° uebersetzt I=1:2 H=47.5mm

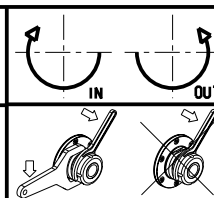

M.T. srl

Via Casino Albini 480
Tel. 0541/956034-957884
Fax 0541/956341
47842 S. GIOVANNI IN M. (RN)
e-mail: mtma@mtmarchetti.com
http://www.mtmarchetti.com

PRODUZIONE MODULI ROTANTI



PAGINA DW0336-2-00

Subject to change without notice.

04/2020

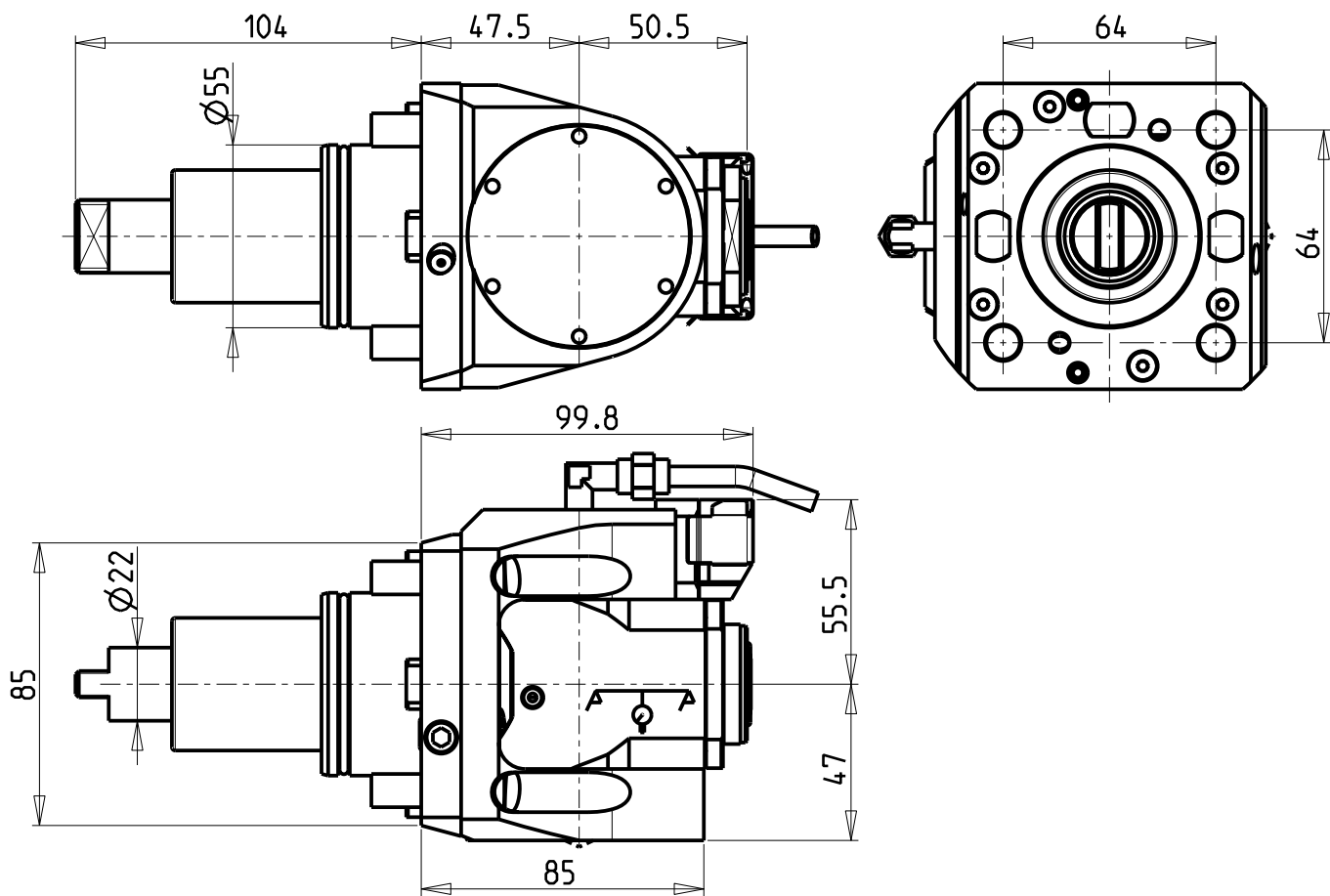

ATTENZIONE - ATTENTION - ACHTUNG

- Su macchine PUMA 280. PUMA TT1500-TT1800-TT2100 serie non arriva in centro mandrino.
- On machines PUMA 280. PUMA TT1500-TT1800-TT2100 series tool does not get to the centre of the spindle axis.
- Auf Maschinen PUMA 280. PUMA TT1500-TT1800-TT2100 serie erreicht das Werkzeug nicht die Mitte der Werkzeug-Achse.

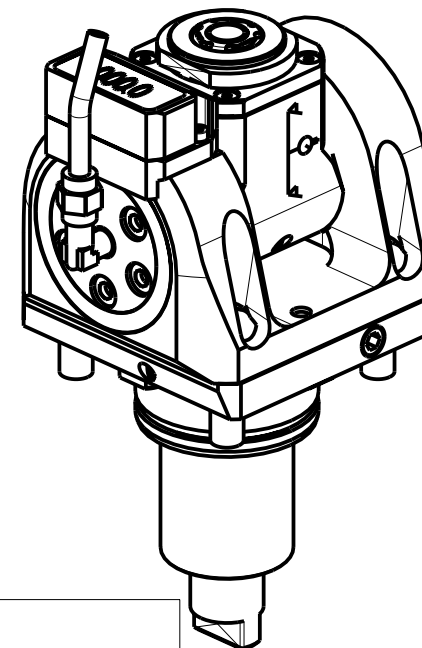

Cod. MT	Mandrino Spindle Spindel	I	RPM	Coppia Max Max Torque Max Drehmoment	Reversibile lato mandrino/contromandrino Reversible sub/main spindle side Umkehrbare Spindelsete/Gegenspindelsete	Lubrificazione int. Coolant through Innenkuehlung	Lubrificazione est. Ext. coolant Aussenkuehlung	CHIAVI INCLUSE Keys included Schluessel inbegriffen			
								CHUB19_SP3	CHUB32	CHTAER16ZC	CHESL07
DW00665316	ERA16	1:2	12000	8Nm	X	-	X	CHUB19_SP3	CHUB32	CHTAER16ZC	CHESL07
DW00665416	ERA16	1:2	12000	8Nm	X	P=70bar	X	CHUB19_SP3	CHUB32	CHTAER16ZC	CHESL07

DOOSAN BMT 55
 MOD: PUMA 230-240M/MS-280LM - PUMA 1500-2000-2500M/MS/Y/SY - LINX 300 M - PUMA 2100 12ST. - PUMA 2600 16ST.
 PUMA TT1500-1800-2100MS/SY/SYY - TL2000-2500 (M) - PUMA GT2100-2600 M - PUMA H250TM - PUMA QL200HM

MODULO MOTORIZZATO ORIENTABILE +/-90° MOLTIPLICATO I=1:2 CON NONIO DIGITALE H=47.5mm
 +/-90° adjustable angle driven tool geared-up I=1:2 with digital display H=47.5mm
 Angetriebenes Werkzeug schwenkbar +/-90° uebersetzt I=1:2 mit digital display H=47.5mm

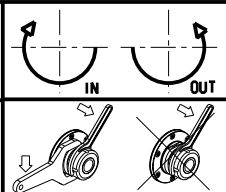

M.T. srl
 Via Casino Albini 480
 Tel. 0541/956034-957884
 Fax 0541/956341
 47842 S. GIOVANNI IN M. (RN)
 e-mail: mtma@mtmarchetti.com
 http://www.mtmarchetti.com

PRODUZIONE MODULI ROTANTI

 PAGINA DW0336-2-01

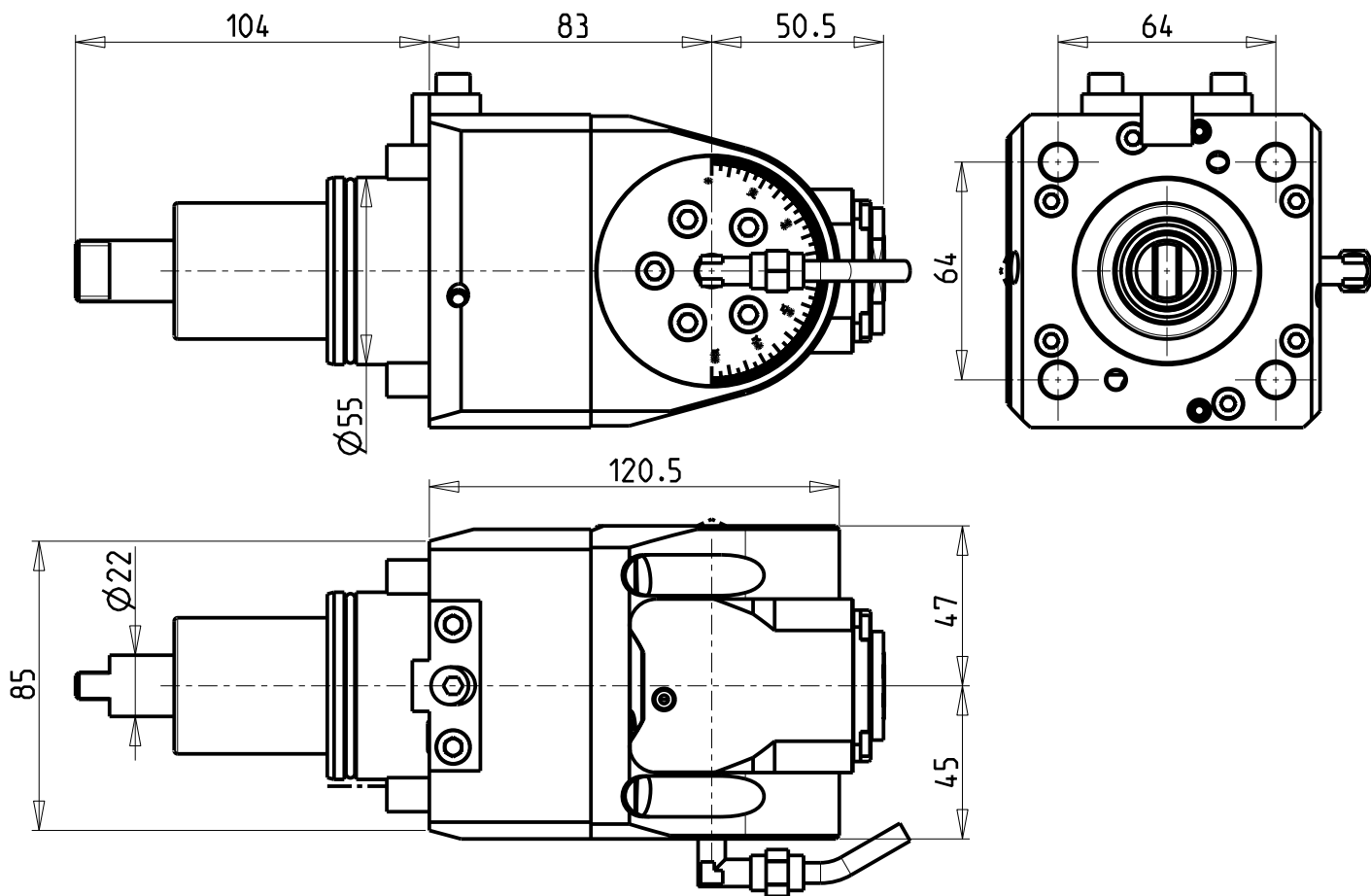
Subject to change without notice.



ATTENZIONE - ATTENTION - ACHTUNG

- Per lo smontaggio degli utensili utilizzare sempre la chiave di contrasto come indicato nel manuale d'uso.
- For disassembly of the tools use always the contrast key as mentioned in the user instructions.
- Fuer das Abmontieren der Werkzeuge immer den Gegenschlüssel benutzen wie in der Bedienungsanleitung erwaeht.

ATTENZIONE - ATTENTION - ACHTUNG

- VERIFICARE LE MISURE DI INGOMBRO PER POSSIBILE INTERFERENZA SU ALCUNI MODELLI DI MACCHINE
- Please check the overall sizes for possible interferences on some machine models
- Bitte überprüfen sie das ausmass um mögliche interferenzen auf einigen maschinen modellen zu vermeiden

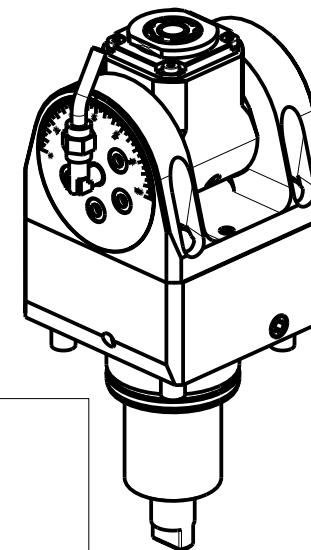

Cod. MT	Mandrino Spindle Spindel	I	RPM	Coppia Max Max Torque Max Drehmoment	Reversibile lato mandrino/contromandrino Reversible sub/main spindle side Umkehrbare Spindel-seite/ Gegenspindel-seite	Lubrificazione int. Coolant through Innenkuehlung	Lubrificazione est. Ext. coolant Aussenkuehlung	CHIAVI INCLUSE Keys included Schluessel inbegriffen			
								CHUB19_SP3	CHUB32	CHTAER16ZC	CHESL08
DW00661316	ERA16	1:2	12000	8Nm	X	-	X	CHUB19_SP3	CHUB32	CHTAER16ZC	CHESL08
DW00661416	ERA16	1:2	12000	8Nm	X	P=70bar	X	CHUB19_SP3	CHUB32	CHTAER16ZC	CHESL08

DOOSAN BMT 55

MOD: PUMA 230-240M/MS-280LM - PUMA 1500-2000-2500M/MS/Y/SY - LINX 300 M - PUMA 2100 12ST. - PUMA H250TM
 PUMA TW2600 10ST. - PUMA TT1500-1800-2100MS/SY/SYY - TL2000-2500 (M) - PUMA GT2100-2600 M - PUMA QL200HM

MODULO MOTORIZZATO ORIENTABILE +/-90° MOLTIPLICATO I=1:2 H=83mm

+/-90° adjustable angle driven tool geared-up I=1:2 H=83mm

Angetriebenes Werkzeug schwenkbar +/-90° uebersetzt I=1:2 H=83mm

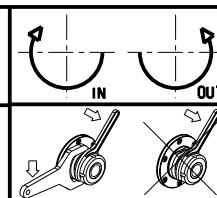

M.T. srl

Via Casino Albini 480
 Tel. 0541/956034-957884
 Fax 0541/956341
 47842 S. GIOVANNI IN M. (RN)
 e-mail: mtma@mtmarchetti.com
 http://www.mtmarchetti.com

PRODUZIONE MODULI ROTANTI



PAGINA DW0336-2-10

Subject to change without notice.

04/2020

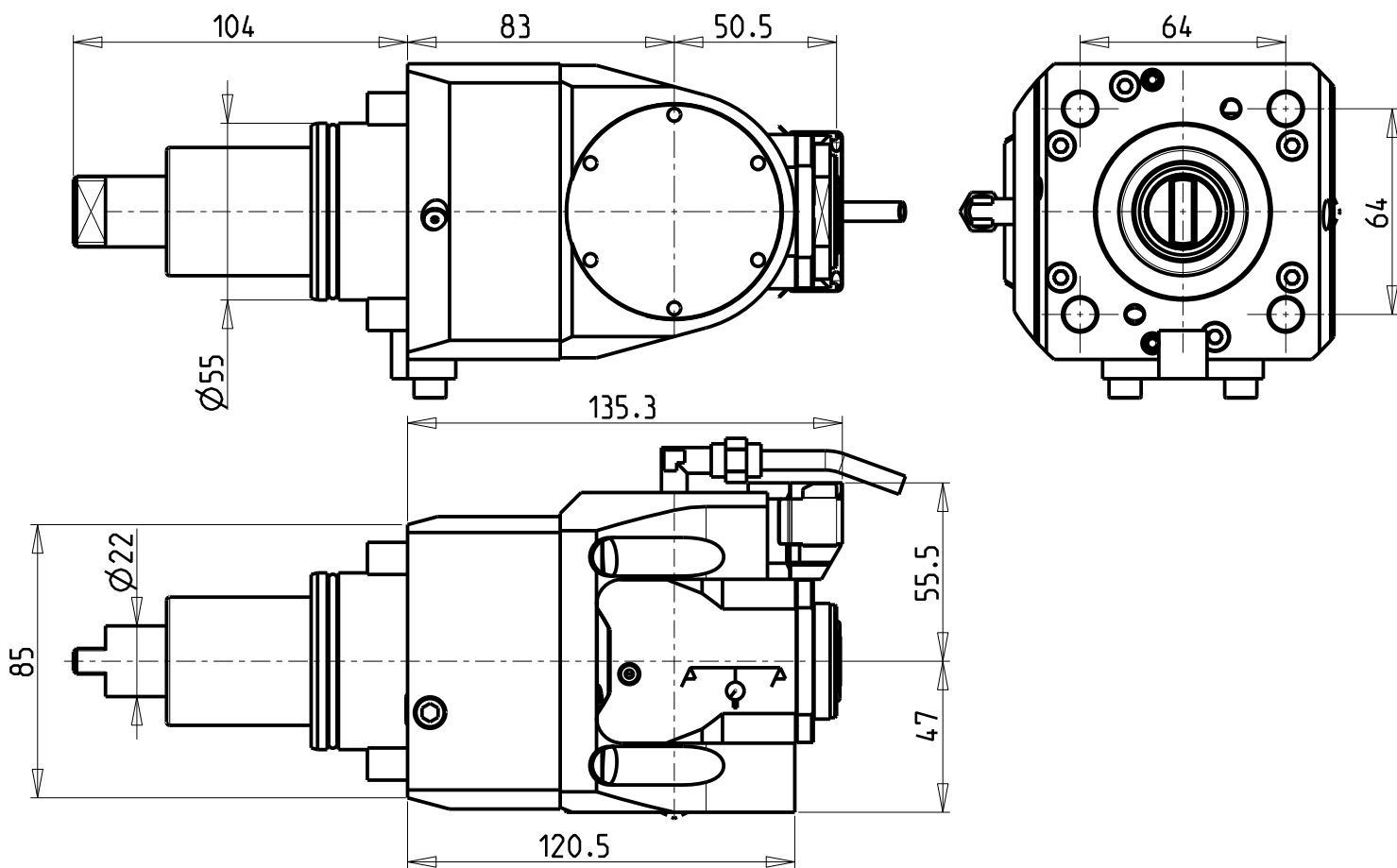

ATTENZIONE - ATTENTION - ACHTUNG

- Per lo smontaggio degli utensili utilizzare sempre la chiave di contrasto come indicato nel manuale d'uso.
- For disassembly of the tools use always the contrast key as mentioned in the user instructions.
- Fuer das Abmontieren der Werkzeuge immer den Gegenschlüssel benutzen wie in der Bedienungsanleitung erwaeht.

ATTENZIONE - ATTENTION - ACHTUNG

- VERIFICARE LE MISURE DI INGOMBRO PER POSSIBILE INTERFERENZA SU ALCUNI MODELLI DI MACCHINE
- Please check the overall sizes for possible interferences on some machine models
- Bitte überprüfen sie das ausmass um mögliche interferences auf einigen maschinen modellen zu vermeiden

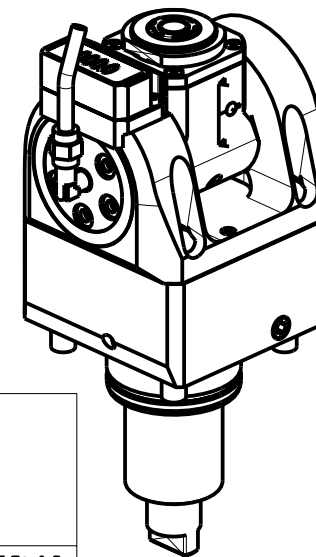

Cod. MT	Mandrino Spindle Spindel	I	RPM	Coppia Max Max Torque Max Drehmoment	Reversibile lato mandrino/contromandrino Reversible sub/main spindle side Umkehrbare Spindel-seite/ Gegenspindel-seite	Lubrificazione int. Coolant through Innenkuehlung	Lubrificazione est. Ext. coolant Aussenkuehlung	CHIAVI INCLUSE Keys included Schluessel inbegriffen			
								CHUB19_SP3	CHUB32	CHTAER16ZC	CHESL08
DW00666316	ERA16	1:2	12000	8Nm	X	-	X	CHUB19_SP3	CHUB32	CHTAER16ZC	CHESL08
DW00666416	ERA16	1:2	12000	8Nm	X	P=70bar	X	CHUB19_SP3	CHUB32	CHTAER16ZC	CHESL08

DOOSAN BMT 55

MOD: PUMA 230-240M/MS-280LM - PUMA 1500-2000-2500M/MS/Y/SY - LINX 300 M - PUMA 2100 12ST.
PUMA TW2600 10ST. - TL2000-2500 (M) - PUMA GT2100-2600 M

MODULO MOTORIZZATO ORIENTABILE +/-90° MOLTIPLICATO I=1:2 CON NONIO DIGITALE H=83mm
+/-90° adjustable angle driven tool geared-up I=1:2 with digital display H=83mm

Angetriebenes Werkzeug schwenkbar +/-90° uebersetzt I=1:2 mit digital display H=83mm

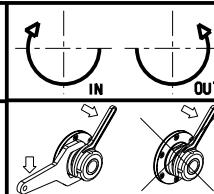

M.T. srl

Via Casino Albini 480
Tel. 0541/956034-957884
Fax 0541/956341
47842 S. GIOVANNI IN M. (RN)
e-mail: mtma@mtmarchetti.com
http://www.mtmarchetti.com

PRODUZIONE MODULI ROTANTI



PAGINA DW0336-2-11

Subject to change without notice.

04/2020

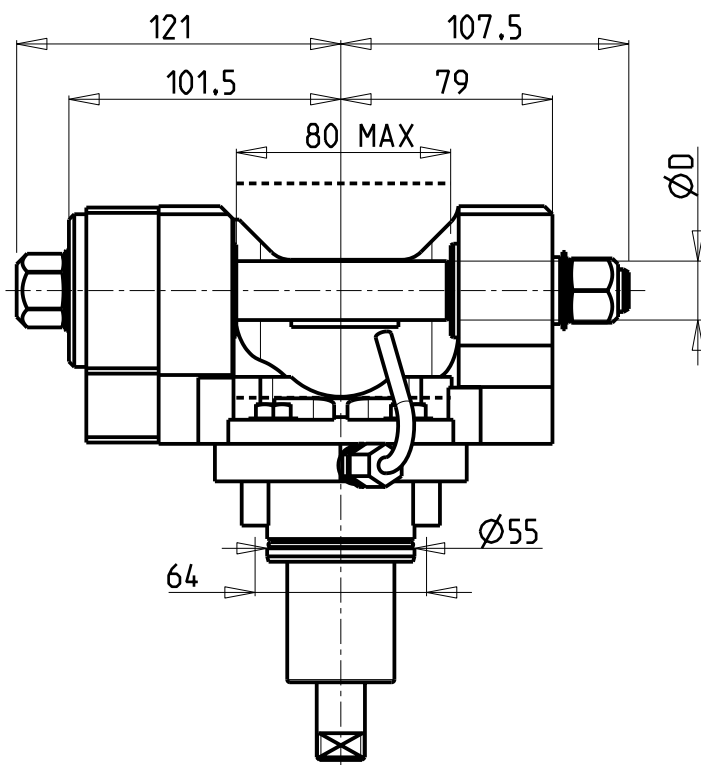
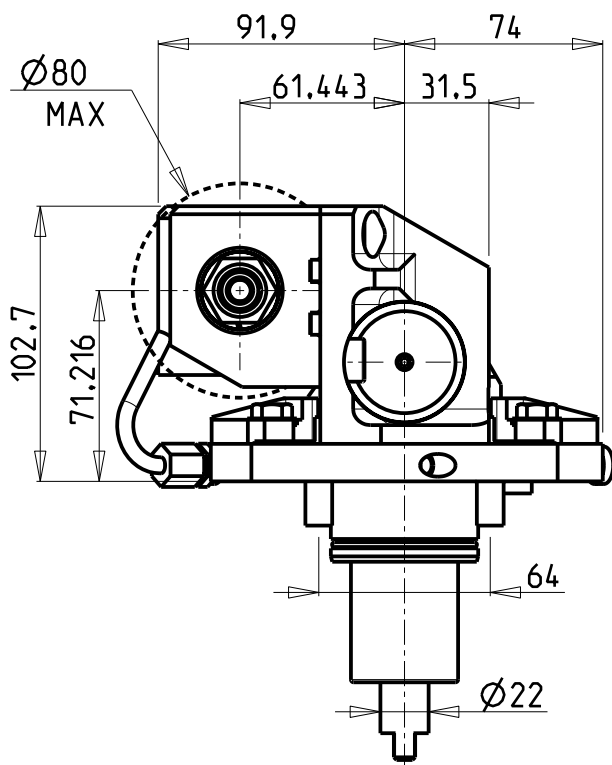

INCLINAZIONE
REGOLABILE ±20°

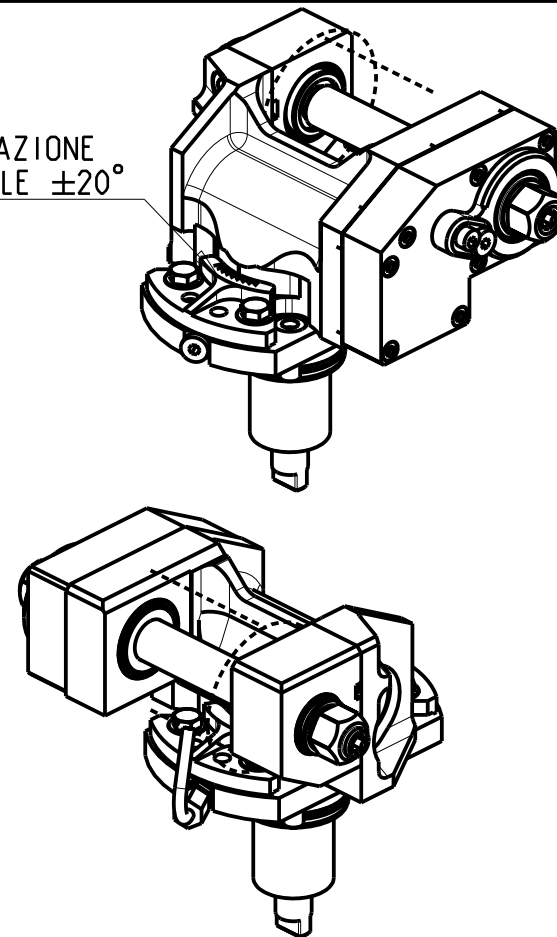

DOTAZIONI - SUPPLIED WITH - AUSSTATTUNG

mm / inch	- N°1 ALBERO + DISTANZIALI - N°1 SHAFT + SPACER - N°1 DORN + ABSTANDSSTUECK
-----------	---

PER ALBERI E DISTANZIALI VEDI PAG. TBL250-1-00
FOR SHAFT END SPACER SEE PAGE TBL250-1-00
FUER DORN UND ABSTANDSSTUECK SEITE TBL250-1-00

Cod. MT	I	RPM max	Coppia Max Max Torque Max Drehmoment	Reversibile lato mandrino/contromandrino Reversible sub/main spindle side Umkehrbare Spindel-seite/ Gegenspindel-seite	Lubrificazione est. Ext. coolant Aussenkuehlung	CHIAVI INCLUSE Keys included Schlüssel inbegriffen		
						D (mm)	D (Inch)	
0621100	1:1	6000	60Nm	X	X	16-22-27-32	3/4"-1"-1 1/4"	CHUB24 CHUB13 CHESL08
0622100	2:1	3000	80Nm	X	X	16-22-27-32	3/4"-1"-1 1/4"	CHUB24 CHUB13 CHESL08

ATTENZIONE - ATTENTION - ACHTUNG
- VERIFICARE LE MISURE DI INGOMBRO PER POSSIBILE INTERFERENZA SU ALCUNI MODELLI DI MACCHINE
- Please check the overall sizes for possible interferences on some machine models
- Bitte überprüfen sie das ausmass um mögliche interferenzen auf einigen maschinen modellen zu vermeiden

DOOSAN BMT 55

MOD: PUMA 230-240M/MS-280LM - PUMA 1500-2000-2500M/SY/SY - LINX 300 M - PUMA 2100 12ST. - PUMA 2600 16ST.
PUMA TW 2600 10ST. - PUMA TT1500-1800-2100MS/SY/SYY - PUMA TL2000-2500 (M) - MX1600/2100ST 12ST. - PUMA H250TM - PUMA QL200HM

MODULO MOTORIZZATO PORTACREATORE

Driven gear hobber

Angetriebenes Zahnradwaeltzraes-Werkzeug

Subject to change without notice.

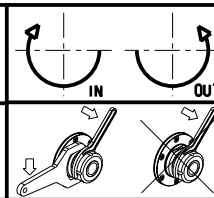

M.T. srl

Via Casino Albini 480
Tel. 0541/956034-957884
Fax 0541/956341
47842 S. GIOVANNI IN M. (RN)
e-mail: mtma@mtmarchetti.com
http://www.mtmarchetti.com

PRODUZIONE MODULI ROTANTI



PAGINA DW0340-2-00

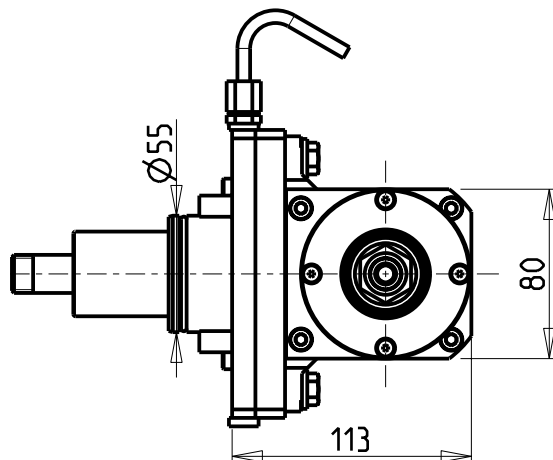
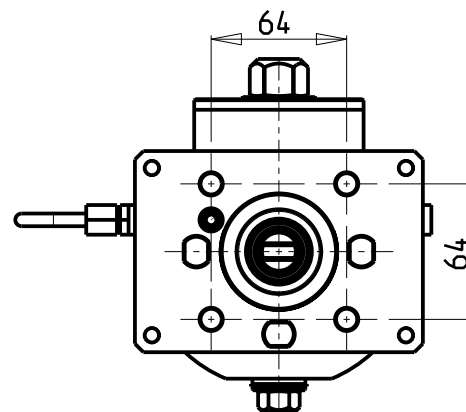
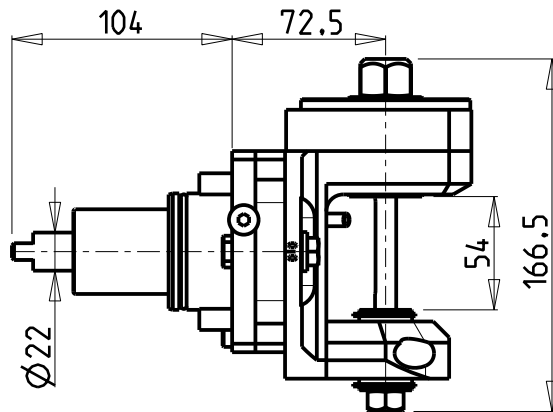
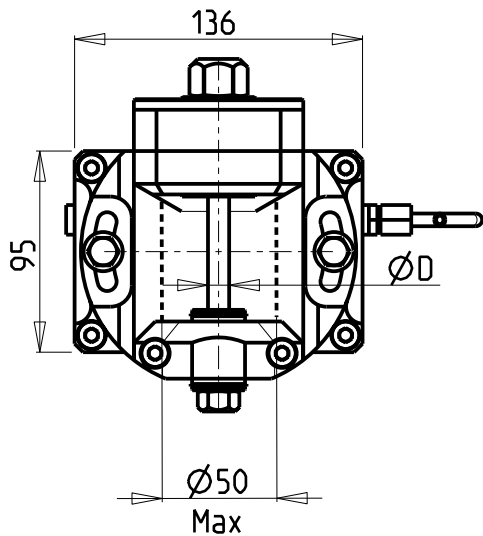

INCLINAZIONE
REGOLABILE $\pm 15^\circ$

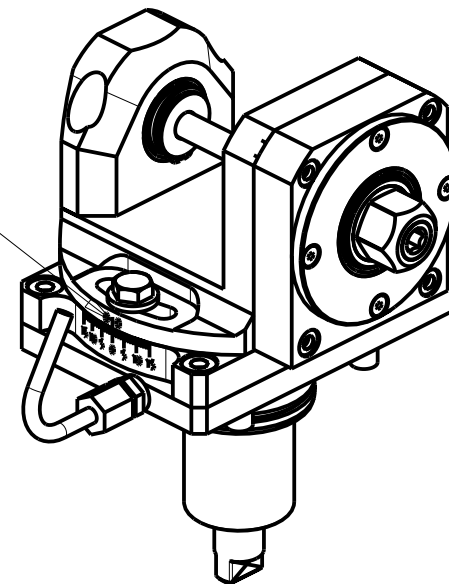

ATTENZIONE - ATTENTION - ACHTUNG

- VERIFICARE LE MISURE DI INGOMBRO PER POSSIBILE INTERFERENZA SU ALCUNI MODELLI DI MACCHINE
- Please check the overall sizes for possible interferences on some machine models
- Bitte überprüfen sie das ausmass um mögliche interferenzen auf einigen maschinen modellen zu vermeiden

Cod. MT	I	RPM max	Coppia Max Max Torque Max Drehmoment	Lubrificazione est. Ext. coolant Aussenkuehlung	D (mm)	CHIAVI INCLUSE Keys included Schlüssel inbegriffen					
						CHUB24	CHUB13	CHESL08	CHESL06	CHESL04	-
DW 00051108	1:1	6000	50Nm	X	8	CHUB24	CHUB13	CHESL08	CHESL06	CHESL04	-
DW 00051110	1:1	6000	50Nm	X	10	CHUB24	CHUB17	CHUB13	CHESL08	CHESL06	CHESL05
DW 00051113	1:1	6000	50Nm	X	13	CHUB24	CHUB19	CHUB13	CHESL08	CHESL06	-
DW 00051116	1:1	6000	50Nm	X	16	CHUB24	CHUB13	CHESL08	CHESL06	-	-

DOOSAN BMT 55

MOD: PUMA 230-240M/MS-280LM - PUMA 1500-2000-2500M/MS/Y/SY - LINX 300 M - PUMA 2100 12ST. - PUMA 2600 16ST.
PUMA TW 2600 10ST. - PUMA TT 1500-1800-2100MS/SY/SYY - PUMA TL2000-2500 (M) - MX1600/2100ST 12ST. - PUMA H250TM - PUMA QL200HM

MODULO MOTORIZZATO PORTACREATORE RADIALE

Radial driven gear hobber

Radial Angetriebenes Zahnradwaelzfraes-Werkzeug

Subject to change without notice.

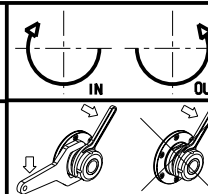

M.T. srl

Via Casino Albini 480
Tel. 0541/956034-957884
Fax 0541/956341
47842 S. GIOVANNI IN M. (RN)
e-mail: mtma@mtmarchetti.com
http://www.mtmarchetti.com

PRODUZIONE MODULI ROTANTI



PAGINA DW0340-2-30

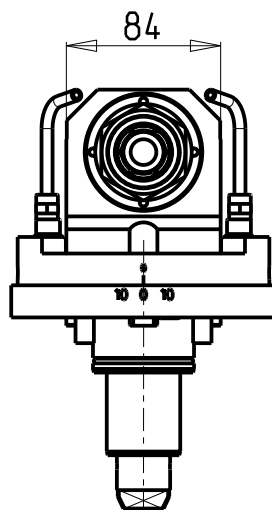
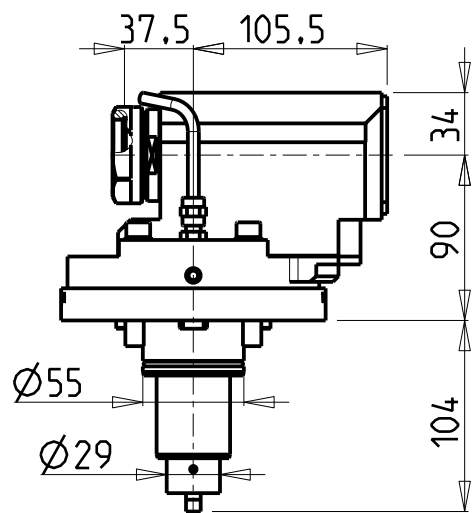
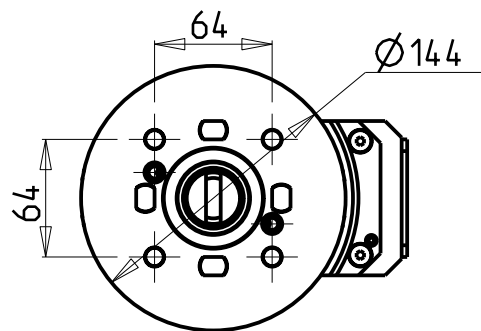

ATTENZIONE - ATTENTION - ACHTUNG

- VERIFICARE LE MISURE DI INGOMBRO PER POSSIBILE INTERFERENZA SU ALCUNI MODELLI DI MACCHINE
- Please check the overall sizes for possible interferences on some machine models
- Bitte überprüfen sie das ausmass um mögliche interferenzen auf einigen maschinen modellen zu vermeiden

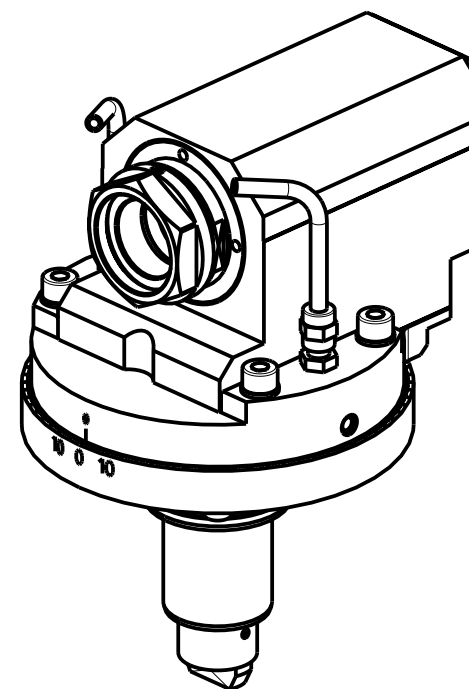

PER PORTAUTENSILI MODULARI MTSK-40 VEDI PAG. TBL300-1-40
 FOR MTSK-40 QUICK CHANGE TOOLHOLDERS CLAMPINGS SEE PAGE TBL300-1-40
 FUER MTSK-40 MODULARE WERKZEUGAUFNAHMEN SIEHE SEITE TBL300-1-40

Cod. MT	Mandrino Spindle Spindel	I	RPM	Coppia Max Max Torque Max Drehmoment	Reversibile lato mandrino/contromandrino Reversible sub/main spindle side Umkehrbare Spindel-seite/ Gegenspindel-seite	Lubr.esterna Ext. coolant Aussenkuehlung	CHIAVI INCLUDE Keys included Schluessel einbegriffen
DW01760100	MTSK-40	1:1	6000	50Nm	X	X	n°2 CHUB46

DOOSAN BMT 55

MOD: PUMA 1500-2000-2500M/MS/Y/SY - PUMA 2100 12ST. - PUMA TT1500-1800-2100MS/SY/SYY

MODULO MOTORIZZATO ASSIALE MTSK PER POWER SKIVING H=90mm

Axial MTSK driven tool for Power Skiving H=90mm

Axial MTSK angetriebenes Werkzeug fuer Power Skiving H=90mm

Subject to change without notice.

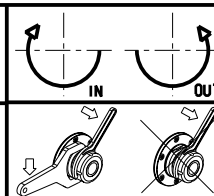

M.T. srl

Via Casino Albini 480
 Tel. 0541/956034-957884

Fax 0541/956341

47842 S. GIOVANNI IN M. (RN)

e-mail: mtma@mtmarchetti.com

http://www.mtmarchetti.com

PRODUZIONE MODULI ROTANTI



PAGINA DW0350-2-00-K

ATTENZIONE - ATTENTION - ACHTUNG

- VERIFICARE LE MISURE DI INGOMBRO PER POSSIBILE INTERFERENZA SU ALCUNI MODELLI DI MACCHINE
- Please check the overall sizes for possible interferences on some machine models
- Bitte überprüfen sie das ausmass um mögliche interferenzen auf einigen maschinen modellen zu vermeiden

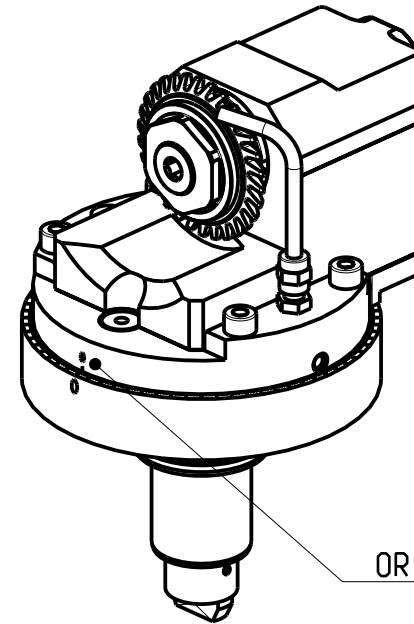
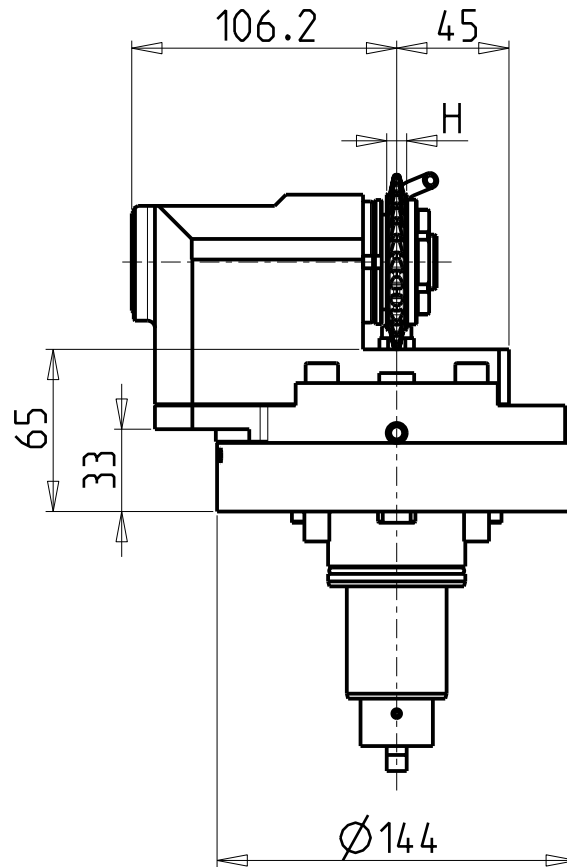
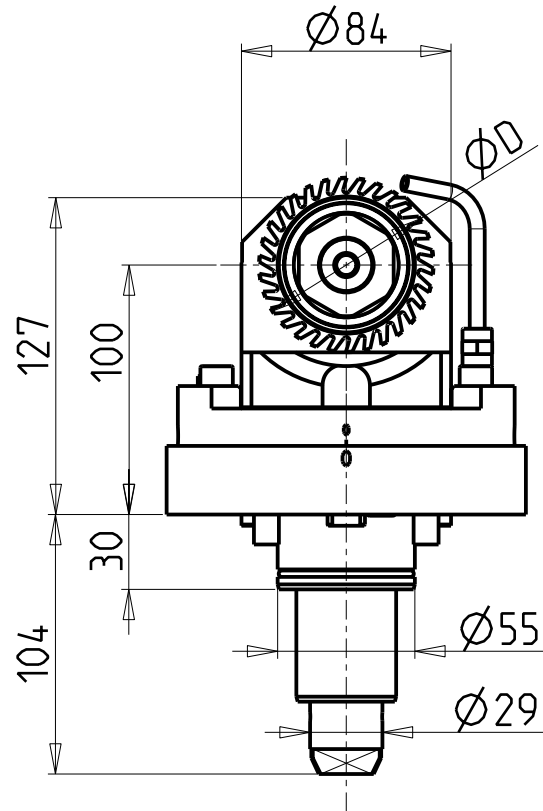

ORIENTABILE DI 360°

Cod. MT	Mandrino Spindle Spindel	I	RPM	Coppia Max Max Torque Max Drehmoment	Reversibile lato mandrino/contromandrino Reversible sub/main spindle side Umkehrbare Spindelseite/ Gegenspindelseite	Lubrificazione est. Ext. coolant Aussenkuehlung	ØD	H	CHIAVI INCLUSE Keys included Schluessel einbegriffen			
									CHUB38	CHESLO6	CHESLO7	CHESLO8
DW 01628022	Ø22x12	1:1	6000	50Nm	X	X	63-70-80	MAX 12	CHUB38	CHESLO6	CHESLO7	CHESLO8
DW 01628125	Ø1"x12	1:1	6000	50Nm	X	X	63-70-80	MAX 12	CHUB38	CHESLO6	CHESLO7	CHESLO8

DOOSAN BMT 55

MOD: PUMA 230-240M/MS-280LM - PUMA 1500-2000-2500M/MS/Y/SY - LINX 300 M - PUMA 2100 12ST. - PUMA H250TM
 PUMA TW 2600 10ST. - PUMA TT1500-1800-2100MS/SY/SYY - PUMA TL2000-2500 (M) - MX1600/2100ST 12ST. - PUMA QL200HM

MODULO MOTORIZZATO PER VITI SENZA FINE

Driven tool for worm screws

Angetriebenes werkzeug für schrauben ohne ende

Subject to change without notice.

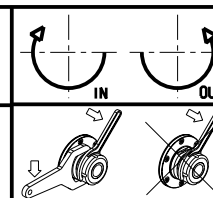

M.T. srl

Via Casino Albini 480
 Tel. 0541/956034-957884
 Fax 0541/956341
 47842 S. GIOVANNI IN M. (RN)
 e-mail: mtma@tmarchetti.com
 http://www.tmmarchetti.com

PRODUZIONE MODULI ROTANTI



PAGINA DW0359-2-00

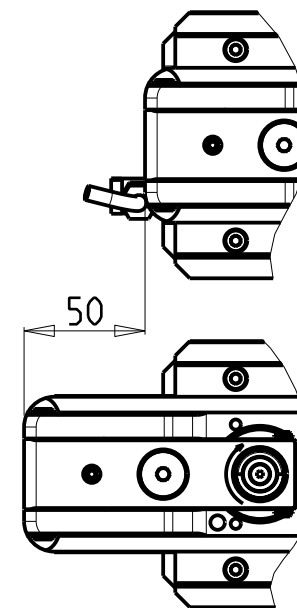
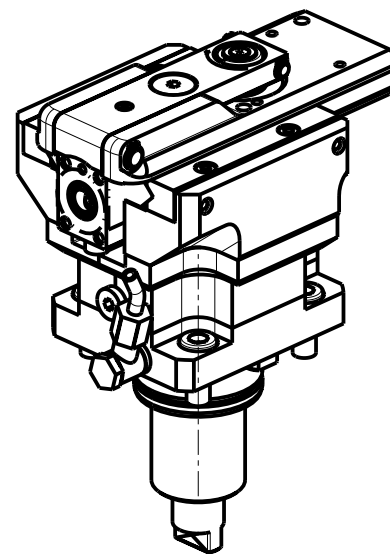
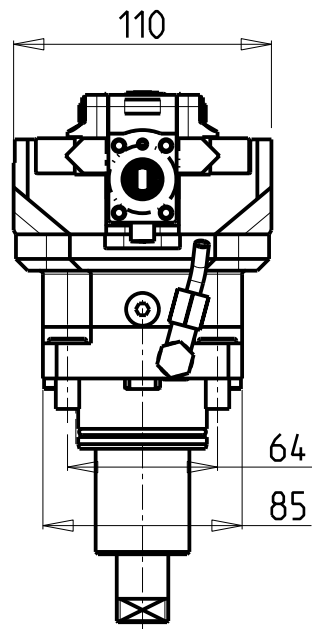
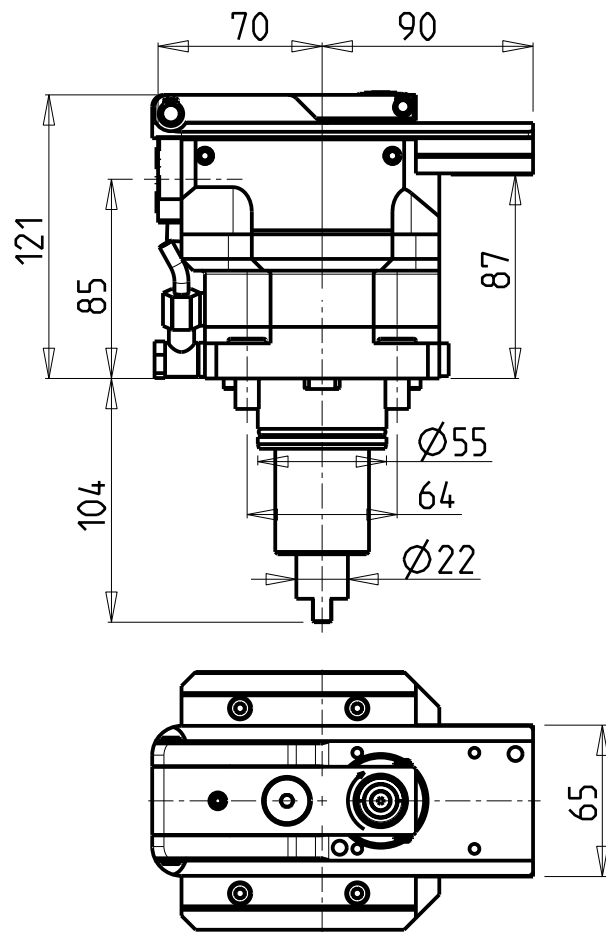

ATTENZIONE - ATTENTION - ACHTUNG

- VERIFICARE LE MISURE DI INGOMBRO PER POSSIBILE INTERFERENZA SU ALCUNI MODELLI DI MACCHINE
- Please check the overall sizes for possible interferences on some machine models
- Bitte überprüfen sie das ausmass um mögliche interferenzen auf einigen maschinen modellen zu vermeiden

PER UTENSILI STOZZATORI VEDI PAG. TBL400-1-00
 FOR DRIVEN SLOTTING TOOL CUTTING-TOOLS SEE PAGE TBL400-1-00
 FÜR NUTENSTOSS-WERKZEUG SCHNEIDWERKZEUGE SIEHE SEITE TBL400-1-00

Cod. MT	I	RPM MAX	Reversibile lato mandrino/contromandrino Reversible sub/main spindle side Umkehrbare Spindel-seite/ Gegenspindel-seite	Lubr. esterna Ext. coolant Aussenkuehlung
DW 01030100	4:1	2000	X	X

DOOSAN BMT 55

MOD: PUMA 240M/MS-280LM - PUMA 1500-2000-2500M/MS/Y/SY - LINX 300 M - PUMA 2100 12ST. - PUMA H250TM
 PUMA TT1500-1800-2100MS/SY/SYY - PUMA TL2000-2500 (M) - MX1600/2100ST 12ST. - PUMA QL200HM

MODULO MOTORIZZATO STOZZATORE CORSA 50mm H=85mm

Slotting driven tool 50mm stroke H=85mm

Keilnutenstossmaschine 50mm Hub H=85mm

Subject to change without notice.

M.T. srl

Via Casino Albini 480
 Tel. 0541/956034-957884
 Fax 0541/956341
 47842 S. GIOVANNI IN M. (RN)
 e-mail: mtma@mtmarchetti.com
 http://www.mtmarchetti.com

PRODUZIONE MODULI ROTANTI



PAGINA DW 0360-2-00

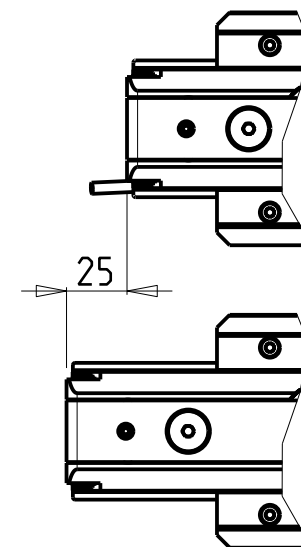
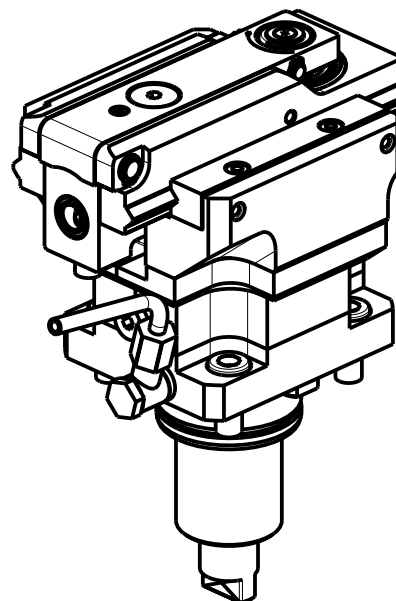
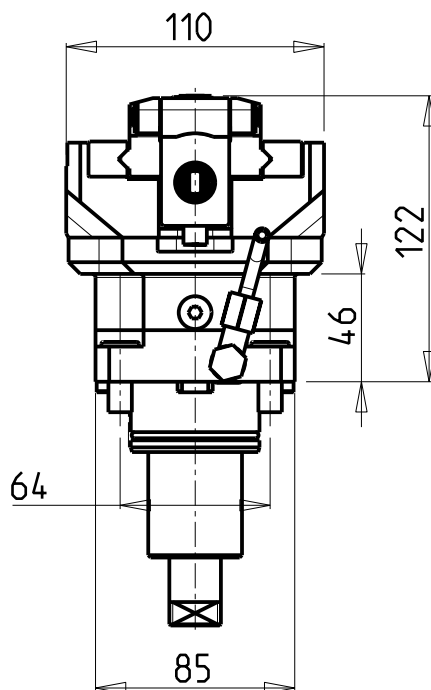
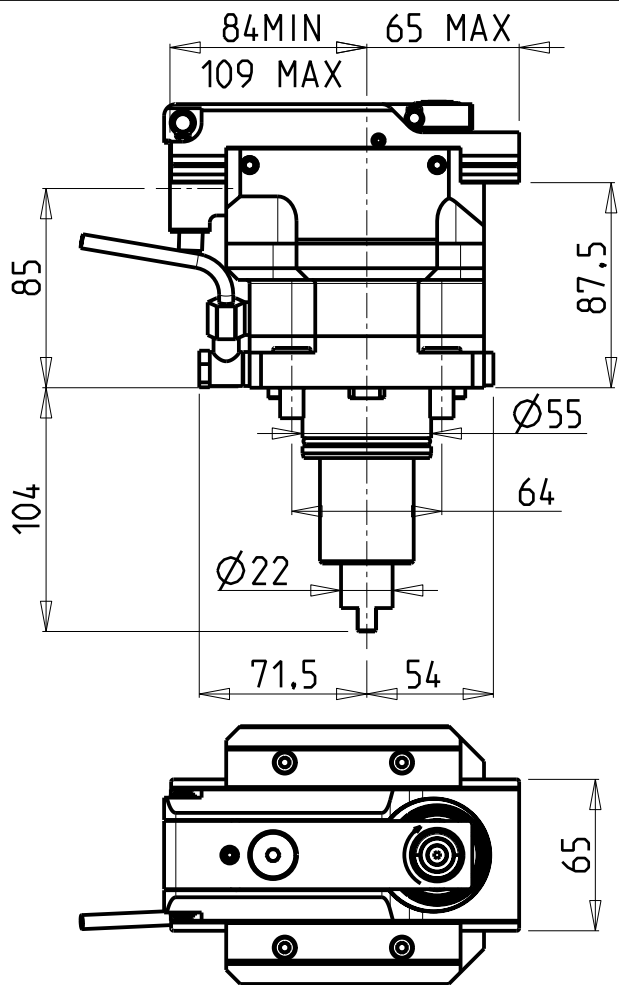

ATTENZIONE - ATTENTION - ACHTUNG

- VERIFICARE LE MISURE DI INGOMBRO PER POSSIBILE INTERFERENZA SU ALCUNI MODELLI DI MACCHINE
- Please check the overall sizes for possible interferences on some machine models
- Bitte überprüfen sie das ausmass um mögliche interferenzen auf einigen maschinen modellen zu vermeiden

PER UTENSILI STOZZATORI VEDI PAG. TBL400-1-00
 FOR DRIVEN SLOTTING TOOL CUTTING-TOOLS SEE PAGE TBL400-1-00
 FÜR NUTENSTOSS-WERKZEUG SCHNEIDWERKZEUGE SIEHE SEITE TBL400-1-00

Cod. MT	I	RPM MAX	Reversibile lato mandrino/contromandrino Reversible sub/main spindle side Umkehrbare Spindel-seite/ Gegenspindel-seite	Lubr. esterna Ext. coolant Aussenkuehlung
DW01030200	4:1	2400	X	X

DOOSAN BMT 55
 MOD: PUMA 240M/MS-280LM - PUMA 1500-2000-2500M/MS/Y/SY - LINX 300 M - PUMA 2100 12ST. - PUMA H250TM
 PUMA TT1500-1800-2100MS/SY/SYY - PUMA TL2000-2500 (M) - MX1600/2100ST 12ST. - PUMA QL200HM

MODULO MOTORIZZATO STOZZATORE CORSA 25mm H=85mm
 Slotting driven tool 25mm stroke H=85mm
 Keilnutenstossmaschine 25mm Hub H=85mm

Subject to change without notice.

M.T. srl
 Via Casino Albini 480
 Tel. 0541/956034-957884
 Fax 0541/956341
 47842 S. GIOVANNI IN M. (RN)
 e-mail: mtma@mtmarchetti.com
 http://www.mtmarchetti.com

PRODUZIONE MODULI ROTANTI



PAGINA DW0360-2-01

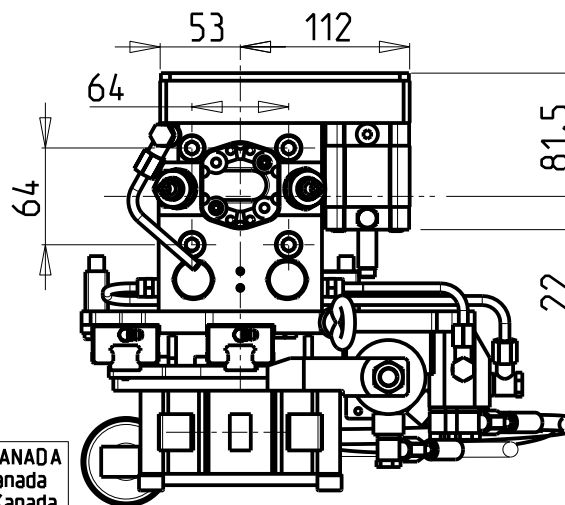
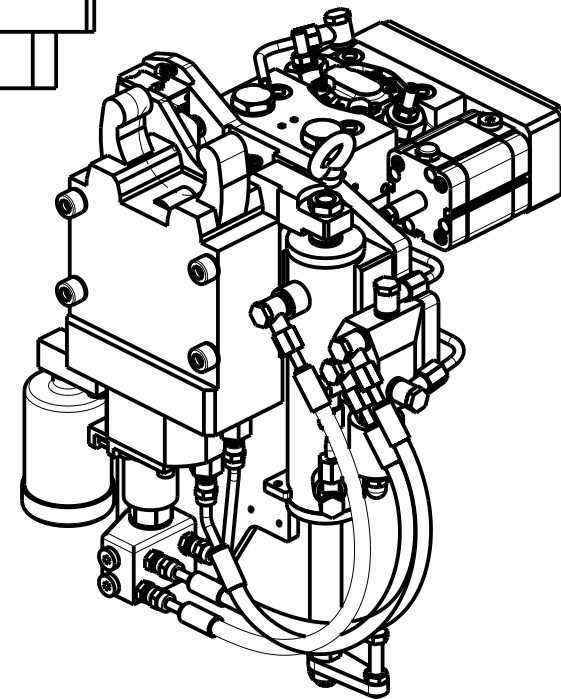
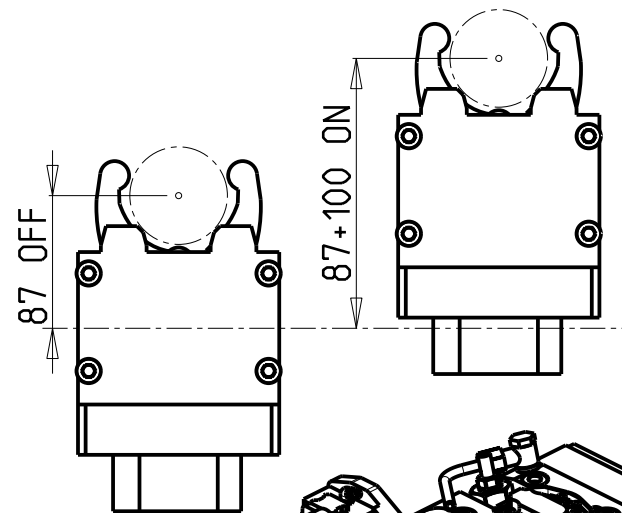
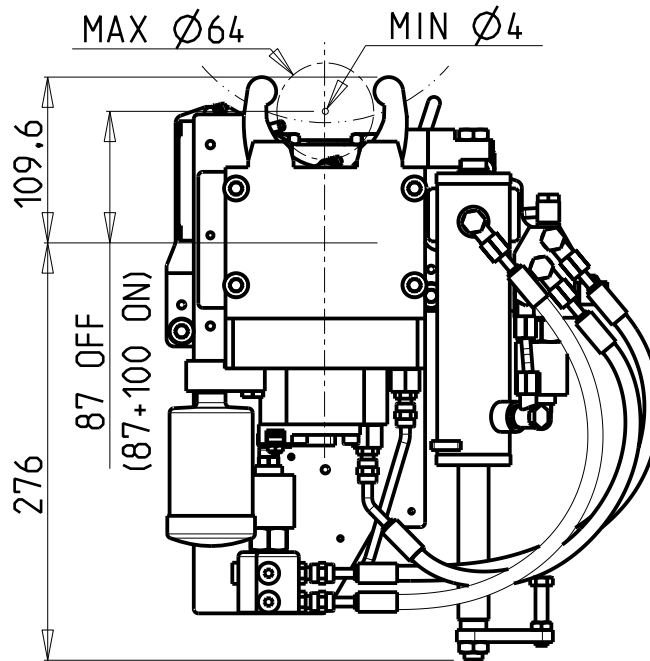
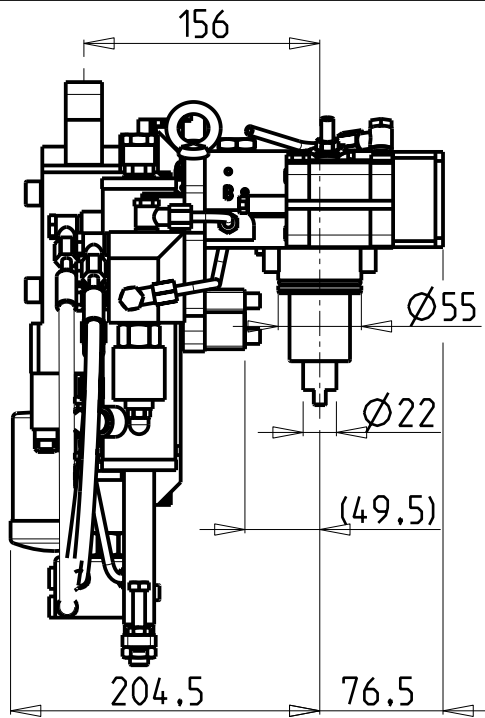

(())	#	CON GESTIONE ELETTRONICA APERTURA COMPLETA DELLA LUNETTA
	#	With Electronic control of steady rest arms complete opening
	#	Mit vollstaendiger elektronischer Oeffnungsbedienung der Luenette

Cod. MT	I	RPM	Lubr.esterna Ext. coolant Aussenkuehlung
DW 00930300	1:1	6000	X
# DW 00930300EU	1:1	6000	X
# DW 00930300US	1:1	6000	X

PER U.S.A.-AUSTRALIA-CANADA
For U.S.A.-Australia-Canada
Fuer U.S.A.-Australien-Kanada

DOOSAN BMT 55

MOD: PUMA TT1500-1800-2100MS/SY/SYY - PUMA TL2000-2500 (M) - MX1600/2100ST 12ST.

MODULO MOTORIZZATO PER LUNETTA RETRATTILE (TAGLIA 1)

Driven toolholder for sliding steady rest (Size 1)

Luenettenwerkzeug zurueck versetzte Version (Groesse 1)

Subject to change without notice.

M.T. srl

Via Casino Albini 480
Tel. 0541/956034-957884
Fax 0541/956341
47842 S. GIOVANNI IN M. (RN)
e-mail: mtma@mtmarchetti.com
http://www.mtmarchetti.com

PRODUZIONE MODULI ROTANTI



PAGINA DW0363-2-00

04/2020

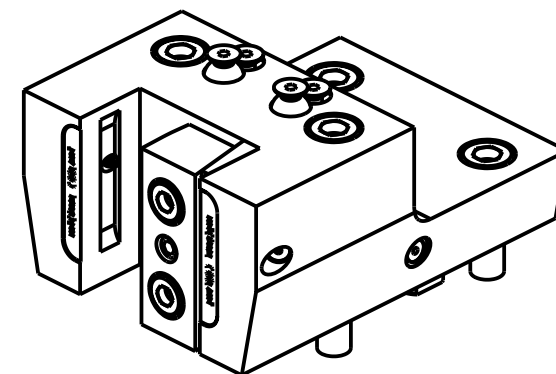
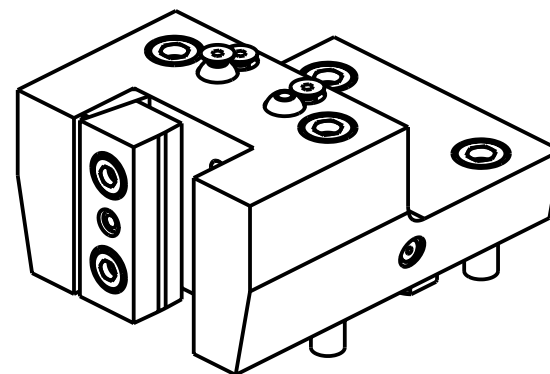
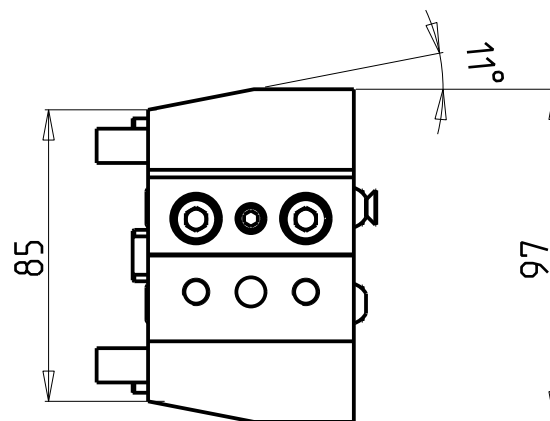
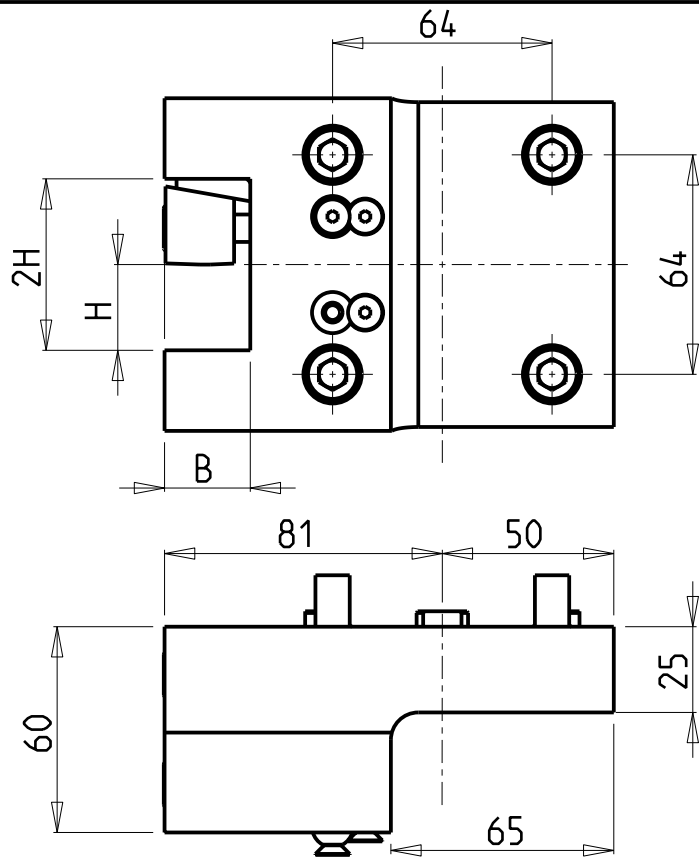

DW 02222510

Cod. MT	N°Utensili N°Tools N°Werkzeuge	Reversibile lato mandrino/contromandrino Reversible sub/main spindle side Umkehrbare Spindel-seite/ Gegenspindel-seite	Lubrificazione int. Coolant through Innenkuehlung	Lubrificazione est. Ext. coolant Aussenkuehlung	Misure Dimensions Masse	B	H
DW02222500	1	X	-	X	mm	25	25
DW02222540	1	X	-	X	Inch	1"	1"
DW02222510	1	X	P=70bar	X	mm	25	25

DOOSAN BMT 55

MOD: PUMA 230-240M/MS-280LM - PUMA 1500-2000-2500M/MS/Y/SY - LINX 300 M - PUMA 2100 12ST. - PUMA 2600 16ST.
PUMA TT1500-1800-2100MS/SY/SYY - PUMA TL2000-2500 (M) - MX1600/2100ST 12ST. - PUMA GT2100-2600 M - PUMA H250TM - PUMA QL200HM

PORTAUTENSILE RADIALE SINGOLO QD=25mm / QD=1" H=60mm

Radial single static tool QD=25mm / QD=1" H=60mm

Radial Single-Werkzeughalter QD=25mm / QD=1" H=60mm

Subject to change without notice.

M.T. srl

Via Casino Albini 480
Tel. 0541/956034-957884
Fax 0541/956341
47842 S. GIOVANNI IN M. (RN)
e-mail: mtma@mtmarchetti.com
http://www.mtmarchetti.com

PRODUZIONE MODULI ROTANTI



PAGINA DW0423-2-00

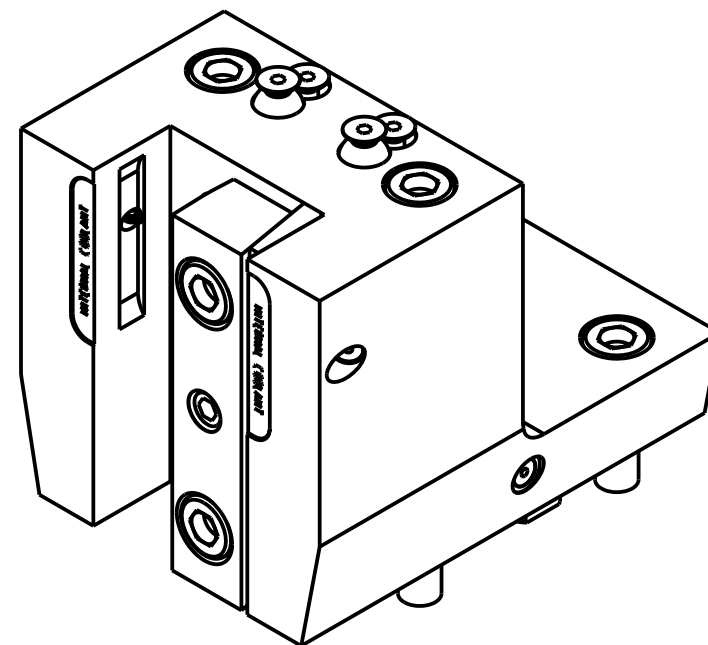
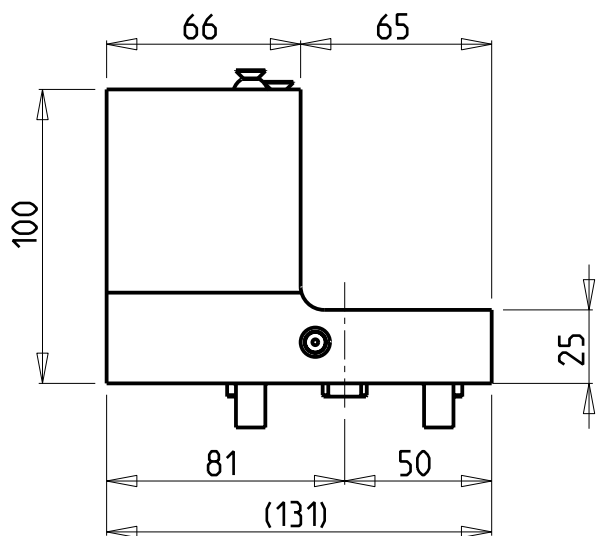
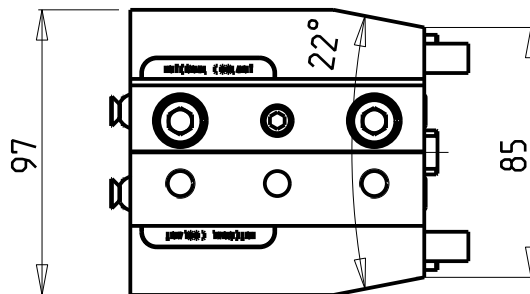
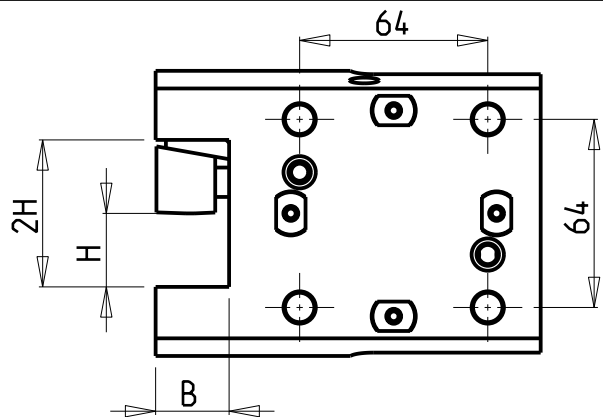

Cod. MT	N°Utensili N°Tools N°Werkzeuge	Reversibile lato mandrino/contromandrino Reversible sub/main spindle side Umkehrbare Spindel-seite/ Gegenspindel-seite	Lubrificazione int. Coolant through Innenkuehlung	Lubrificazione est. Ext. coolant Aussenkuehlung	Misure Dimensions Masse	B	H
DW02902510	1	X	P=70bar	X	mm	25	25

DOOSAN BMT 55

MOD: PUMA 230-240M/MS-280LM - PUMA 1500-2000-2500M/MS/Y/SY - LINX 300 M - PUMA 2100 12ST. - PUMA 2600 16ST. - PUMA H250TM
PUMA TW2600 10ST. - PUMA TT1500-1800-2100MS/SY/SYY - PUMA TL2000-2500 (M) - MX1600/2100ST 12ST. - PUMA QL200HM

PORTAUTENSILE RADIALE SINGOLO QD=25mm H=100mm

Radial single static tool QD=25mm H=100mm

Radial Single-Werkzeughalter QD=25mm H=100mm

Subject to change without notice.

M.T. srl

Via Casino Albini 480
Tel. 0541/956034-957884
Fax 0541/956341
47842 S. GIOVANNI IN M. (RN)
e-mail: mtma@mtmarchetti.com
<http://www.mtmarchetti.com>

PRODUZIONE MODULI ROTANTI



PAGINA DW0423-2-10

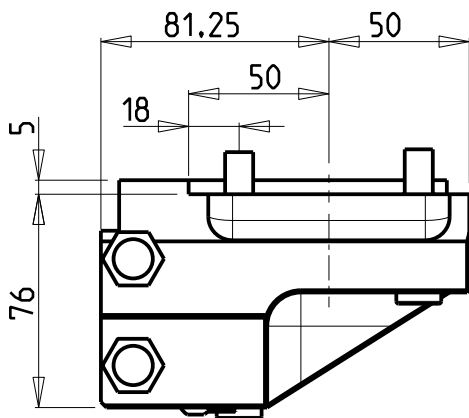
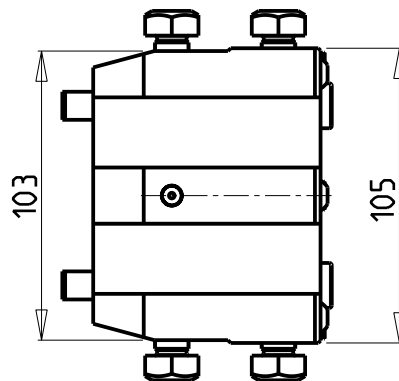
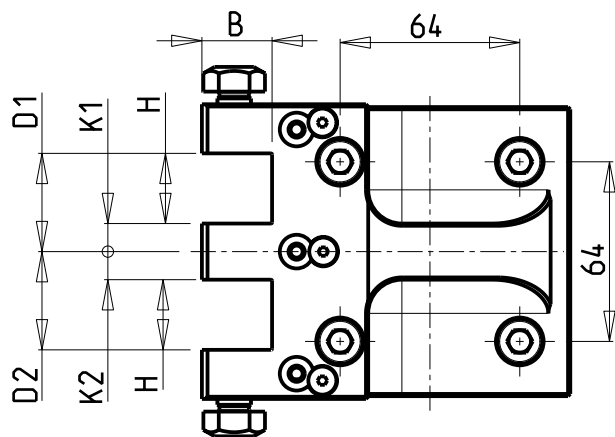

ATTENZIONE - ATTENTION - ACHTUNG

-Su macchine PUMA TT1500-TT1800-TT2100 serie non montare rivolto verso il supporto della torretta.

-On machines PUMA TT1500-TT1800-TT2100 series do not mount towards the turret support.

-Auf Maschinen PUMA TT1500-TT1800-TT2100 serie Nicht der Revolver unterstuetzung zugendand einbauen.

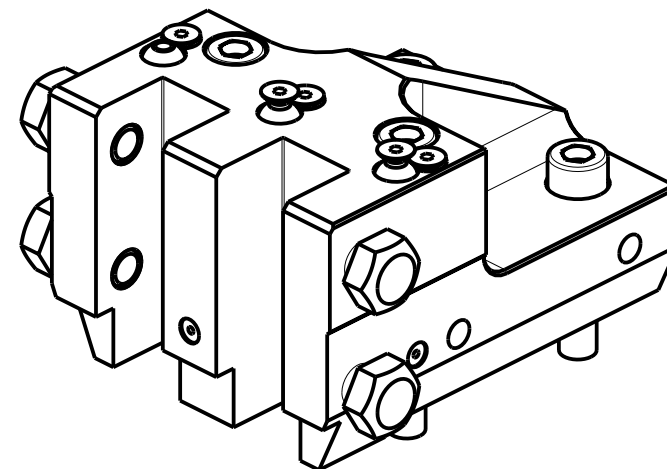

Cod. MT	N°Utensili N°Tools N°Werkzeuge	Reversibile lato mandrino/contromandrino Reversible sub/main spindle side Umkehrbare Spindel-seite/ Gegenspindel-seite	Misure Dimensions Masse	H	B	K1	K2	D1	D2
0772500	2	X	mm	25	25	10	10	35	35
0772540	2	X	inch	1"	1"	3/8"	3/8"	1 3/8"	1 3/8"

DOOSAN BMT 55

MOD: PUMA 1500-2000-2500M/MS/Y/SY - PUMA 2100 12ST. - PUMA TT1500-1800-2100MS/SY/SYY - PUMA TL2000-2500 (M)

PORTAUTENSILE RADIALE SOVRAPPOSTO QD=25mm / QD=1"

Radial single side twin static tool QD=25mm / QD=1"

Radial Werkzeughalter ueberlagert QD=25mm / QD=1"

Subject to change without notice.

M.T. srl

Via Casino Albini 480
Tel. 0541/956034-957884
Fax 0541/956341
47842 S. GIOVANNI IN M. (RN)
e-mail: mtma@mtmarchetti.com
http://www.mtmarchetti.com

PRODUZIONE MODULI ROTANTI



PAGINA DW 0442-2-00

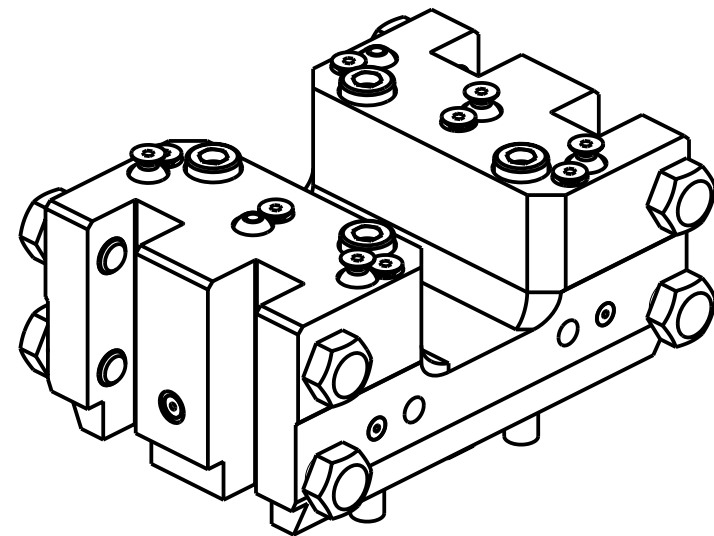
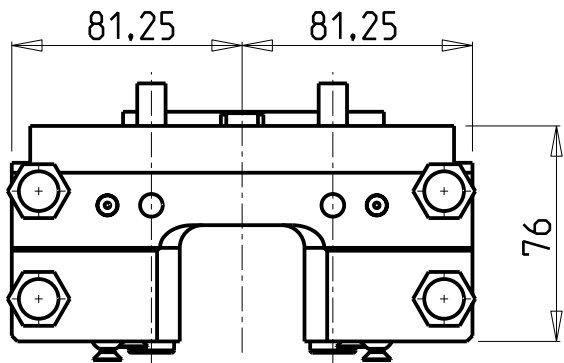
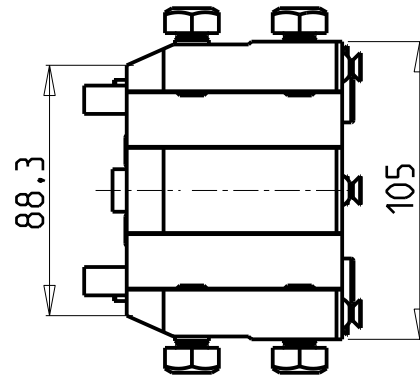
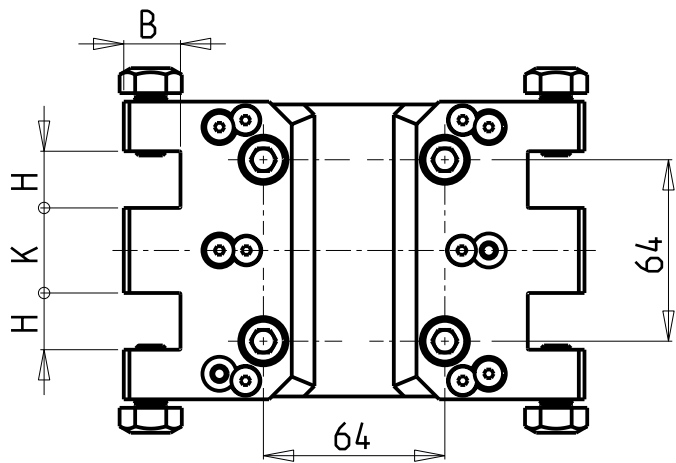

Cod. MT	N°Utensili N°Tools N°Werkzeuge	Reversibile lato mandrino/contromandrino Reversible sub/main spindle side Umkehrbare Spindel-seite/ Gegenspindel-seite	Misure Dimensions Masse	H	K	B
0762000	4	X	mm	20	30	20
0761905	4	X	inch	3/4"	1 1/4"	3/4"
0762500	4	X	mm	25	20	25
0762540	4	X	inch	1"	3/4"	1"

DOOSAN BMT 55

MOD: PUMA 1500-2000-2500M/MS/Y/SY - PUMA 2100 12ST. - PUMA TL2000-2500 (M)

PORTAUTENSILE RADIALE DOPPIO SOVRAPPONTO QD=20mm / QD=3/4" / QD=25mm / QD=1"

Radial double side twin static tool QD=20mm / QD=3/4" / QD=25mm / QD=1"

Radial Doppel-Werkzeughalter ueberlagert QD=20mm / QD=3/4" / QD=25mm / QD=1"

Subject to change without notice.

M.T. srl

Via Casino Albini 480

Tel. 0541/956034-957884

Fax 0541/956341

47842 S. GIOVANNI IN M. (RN)

e-mail: mtma@mtmarchetti.com

http://www.mtmarchetti.com

PRODUZIONE MODULI ROTANTI



PAGINA DW0463-2-00

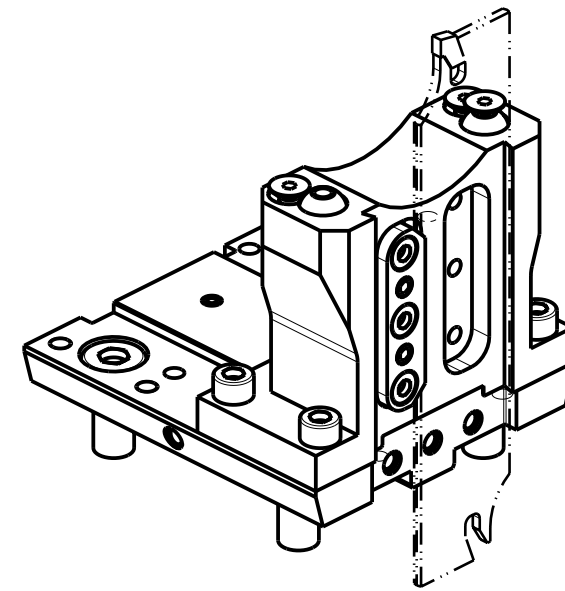
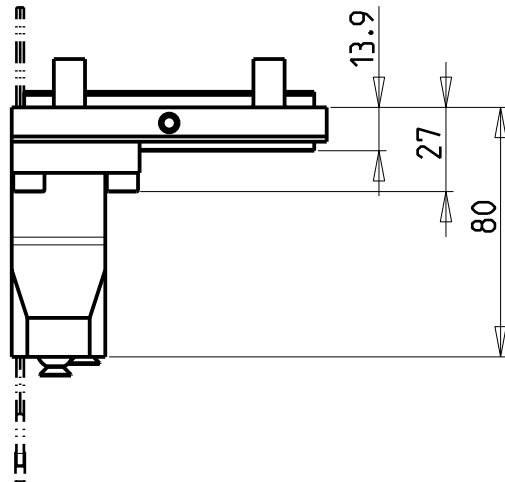
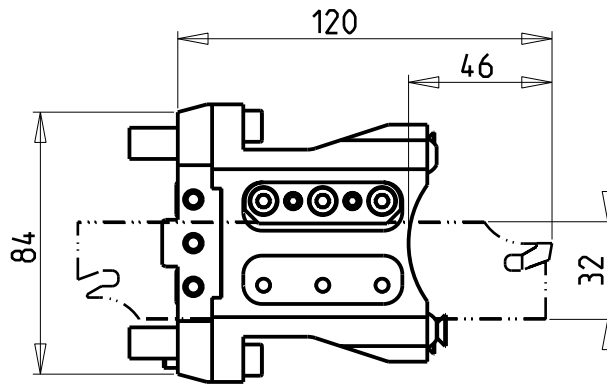
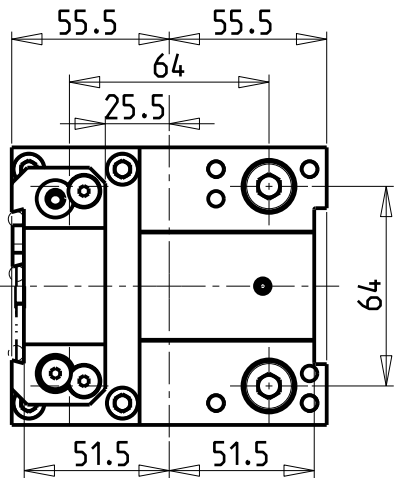

POSSIBILITA' DI LAVORO M3/M4
 OPTION OF M3/M4 WORKING
 ARBEITSMÖGLICHKEIT M3/M4

DOTAZIONI - SUPPLIED WITH - AUSSTATTUNG

- N°1 - LAMA - BLADE - KLINGE ISCAR H=32 Sp. 3/4mm (KENNAMETAL OPTIONAL)
- N°10 - INSERTI - INSERTS - EINLAGEN
- N°1 - CHIAVE A T PER MONTAGGIO INSERTI
 - T-WRENCH FOR INSERT SET UP
 - T-SCHLUESSEL FUER EINSATZSTUECK-MONTAGE

Cod. MT	N°Utensili N°Tools N°Werkzeuge	Reversibile lato mandrino/contromandrino Reversible sub/main spindle side Umkehrbare Spindelseite/ Gegenspindelseite	Lubr.esterna Ext. coolant Aussehenkuehlung
DW02380132	1	X	X

DOOSAN BMT 55

MOD: PUMA 230-240M/MS-280LM - PUMA 1500-2000-2500M/MS/Y/SY - LINX 300 M - PUMA 2100 12ST. - PUMA 2600 16ST.
 PUMA TT1500-1800-2100MS/SY/SYY - PUMA TL2000-2500 (M) - MX1600/2100ST 12ST. - PUMA GT2100-2600 M - PUMA H250TM - PUMA QL200HM

PORTAUTENSILE RADIALE PER LAMA

Radial blade holder
 Radial Abstechhalter

M.T. srl

Via Casino Albini 480
 Tel. 0541/956034-957884
 Fax 0541/956341
 47842 S. GIOVANNI IN M. (RN)
 e-mail: mtma@mtmarchetti.com
 http://www.mtmarchetti.com

PRODUZIONE MODULI ROTANTI



PAGINA DW0520-2-01

Subject to change without notice.

04/2020

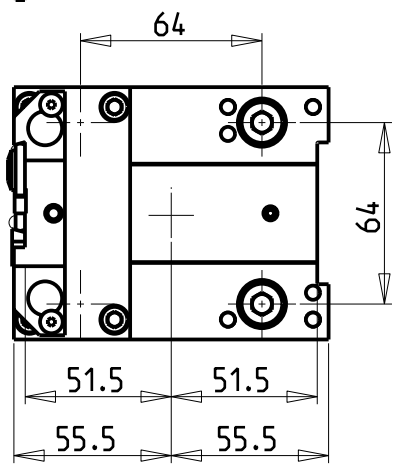
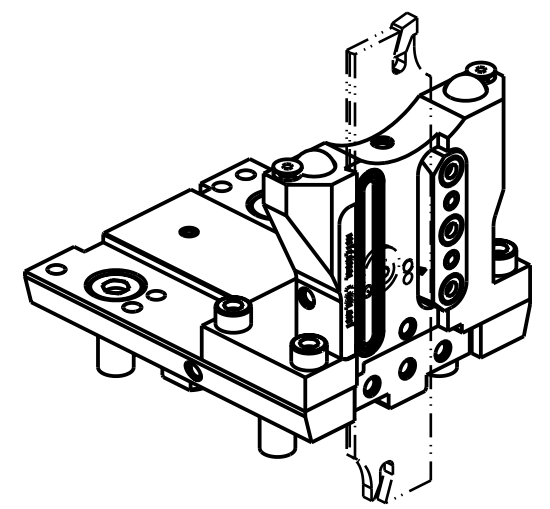
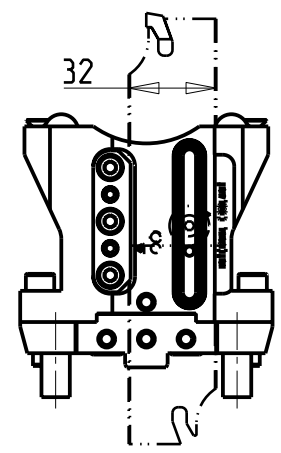
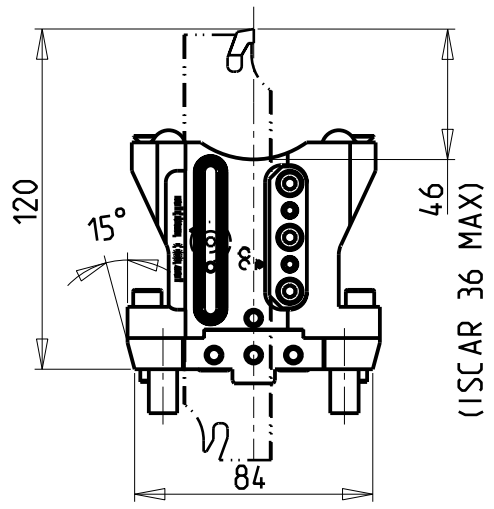
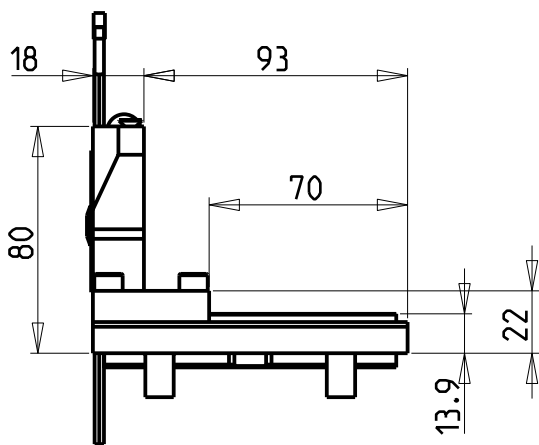

versione dx
right version
version rechts

versione sx
left version
version links

**KIT LAME NON INCLUSI (OPZIONALI)
BLADES NOT SUPPLIED WITH (OPTIONAL)
KLINGEN NICHT INBEGRIFFEN (OPTIONAL)**

- LAMA-BLADE-KLINGE SANDVIK H=32 sp.3 cod. QD_NN2G60C25A
+ INSERTI-INSERTS-EINLAGEN cod. QD_NG_0300_0002_CM_1145 (10 pz.)
- LAMA-BLADE-KLINGE SANDVIK H=32 sp.4 cod. QD_NN2H60C25A
+ INSERTI-INSERTS-EINLAGEN cod. QD_NH_0400_0002_CM_1145 (10 pz.)
- LAMA-BLADE-KLINGE ISCAR H=32 sp.3 cod. SGFH_32K_3
+ INSERTI-INSERTS-EINLAGEN cod. 6011365 (10pz.)
- LAMA-BLADE-KLINGE ISCAR H=32 sp.4 cod. SGFH_32K_4
+ INSERTI-INSERTS-EINLAGEN cod. 6011366 (10pz.)
- LAMA-BLADE-KLINGE WALTER H=32 sp.3 cod. G2042.32N-3T45SX-P
+ INSERTI-INSERTS-EINLAGEN cod. SX-3E300N02-CE4 WSM33S (10pz.) + CHIAVE-KEY cod. FS1494
- LAMA-BLADE-KLINGE WALTER H=32 sp.4 cod. G2042.32N-4T50SX-P
+ INSERTI-INSERTS-EINLAGEN cod. SX-4E400N02-CE4 WSM33S (10pz.) + CHIAVE-KEY cod. FS1494

Cod. MT		N°Utensili N°Tools N°Werkzeuge	Reversibile lato mandrino/contromandrino Reversible sub/main spindle side Umkehrbare Spindelseite/ Gegenspindelseite	Lubr.esterna Ext. coolant Aussenkuehlung	Lubr.interna Coolant through Innenkuehlung
versione dx right version version rechts	versione sx left version version links				
DW 02390132R	DW 02390132L	1	X	X	P=70bar

DOOSAN BMT 55
 MOD: PUMA 230-240M/MS-280LM - PUMA 1500-2000-2500M/MS/Y/SY - LINX 300 M - PUMA 2100 12ST. - PUMA 2600 16ST.
 PUMA TT1500-1800-2100MS/SY/SYY - PUMA TL2000-2500 (M) - MX1600/2100ST 12ST. - PUMA GT2100-2600 M - PUMA H250TM - PUMA QL200HM

PORTAUTENSILE RADIALE PER LAMA CON LUBRIFICAZIONE INTERNA
 Radial blade holder with internal coolant
 Radial Abstechhalter mit Innenkuehlung

Subject to change without notice.

M.T. srl
 Via Casino Albini 480
 Tel. 0541/956034-957884
 Fax 0541/956341
 47842 S. GIOVANNI IN M. (RN)
 e-mail: mtma@mtmarchetti.com
 http://www.mtmarchetti.com

PRODUZIONE MODULI ROTANTI



PAGINA DW0520-2-05

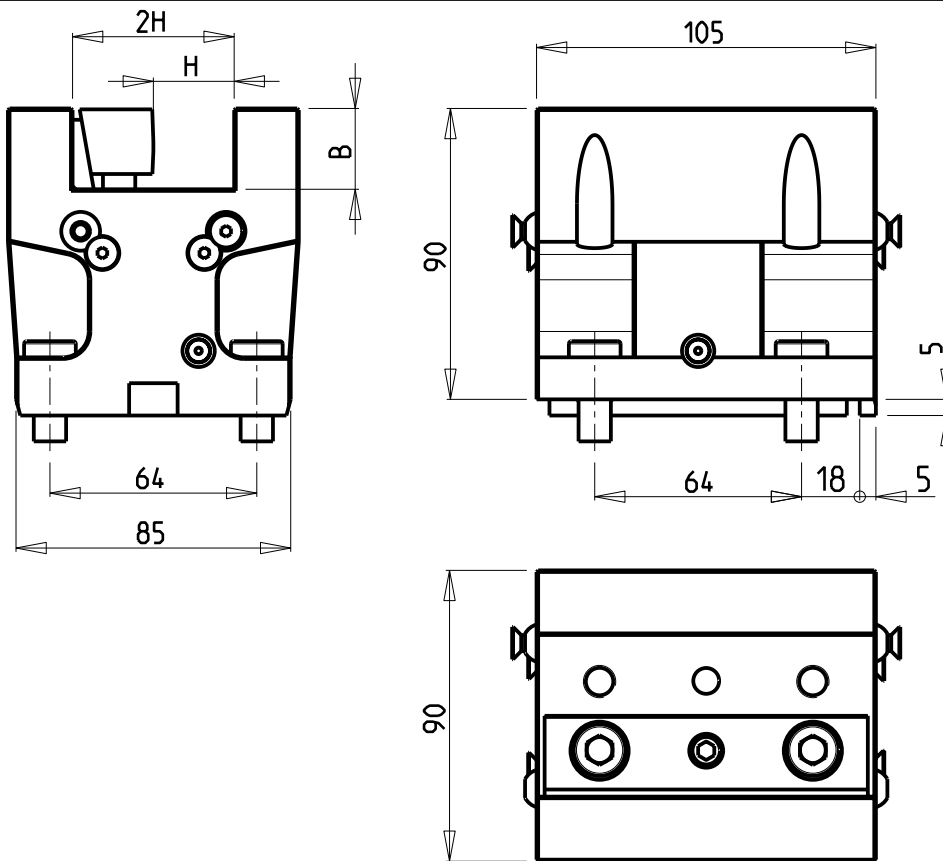

DW 004 22510

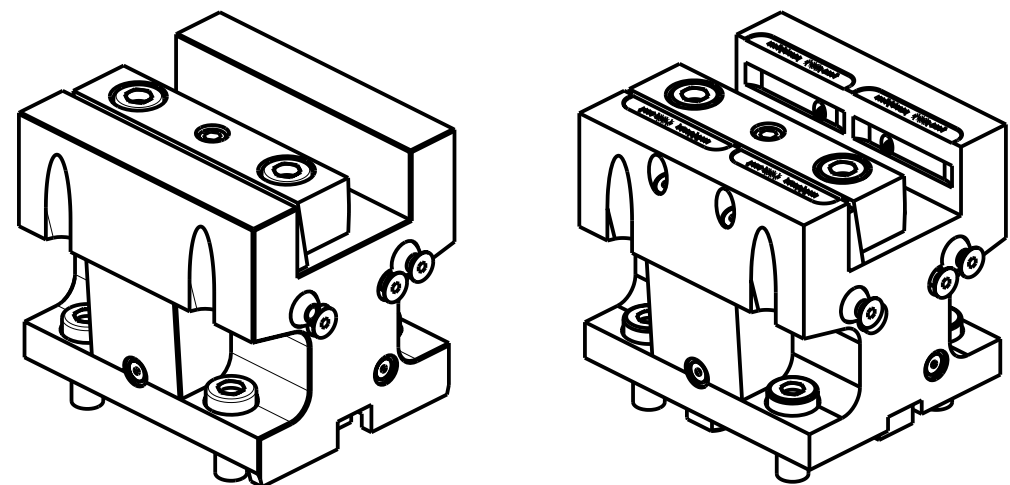

Cod. MT	N°Utensili N°Tools N°Werkzeuge	Reversibile lato mandrino/contromandrino Reversible sub/main spindle side Umkehrbare Spindel-seite/ Gegenspindel-seite	Lubrificazione int. Coolant through Innenkuehlung	Lubrificazione est. Ext. coolant Aussenkuehlung	Misure Dimensions Masse	B	H
DW 004 22500	1	X	-	X	mm	25	25
DW 004 22540	1	X	-	X	Inch	1"	1"
DW 004 22510	1	X	P=70bar	X	mm	25	25

DOOSAN BMT 55

MOD: PUMA 230-240M/MS-280LM - PUMA 1500-2000-2500M/MS/Y/SY - LINX 300 M - PUMA 2100 12ST. - PUMA 2600 16ST.
PUMA TT1500-1800-2100MS/SY/SYY - PUMA TL2000-2500 (M) - MX1600/2100ST 12ST. - PUMA GT2100-2600 M - PUMA H250TM - PUMA QL200HM

PORTAUTENSILE ASSIALE SINGOLO QD=25mm / QD=1"

Axial single static tool QD=25mm / QD=1"

Axial Single-Werkzeughalter QD=25mm / QD=1"

Subject to change without notice.

M.T. srl

Via Casino Albini 480
Tel. 0541/956034-957884
Fax 0541/956341
47842 S. GIOVANNI IN M. (RN)
e-mail: mtma@mtmarchetti.com
http://www.mtmarchetti.com

PRODUZIONE MODULI ROTANTI



PAGINA DW0552-2-00

PER BOCCOLE DI RIDUZIONE VEDI PAG. TBL150-1-00
 FOR REDUCING BUSHINGS SEE PAGE TBL150-1-00
 FÜR REDUZIERBUCHSE SIEHE SEITE TBL150-1-00

KIT ADDUZIONE INTERNA (OPZIONALE)
 KIT FOR INTERNAL COOLANT (OPTIONAL)
 KIT FÜR INTERNE KUEHLMITTELZUFUHR (OPTIONAL)
 Ø50-Ø2" cod. KIT1000002

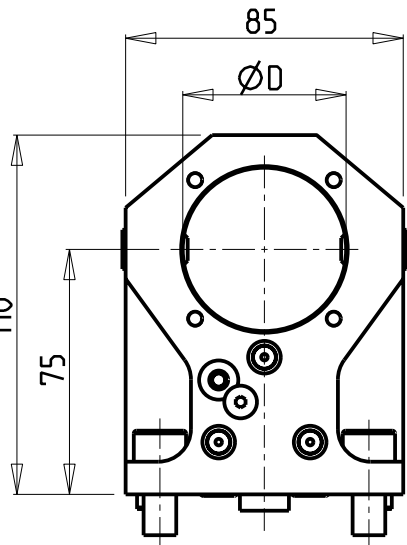
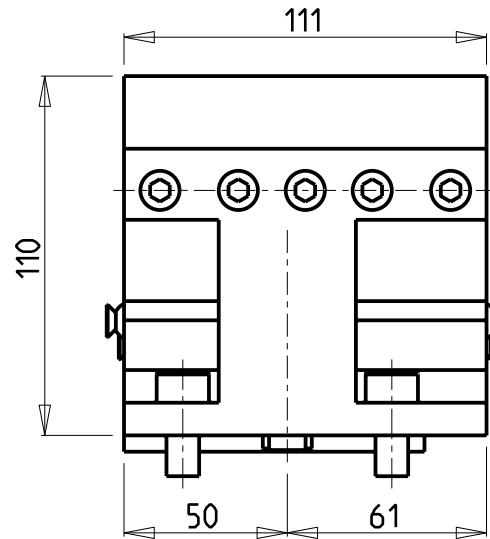
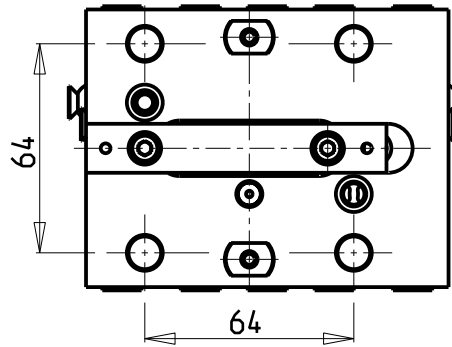
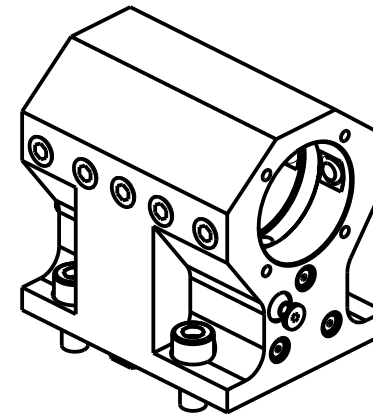
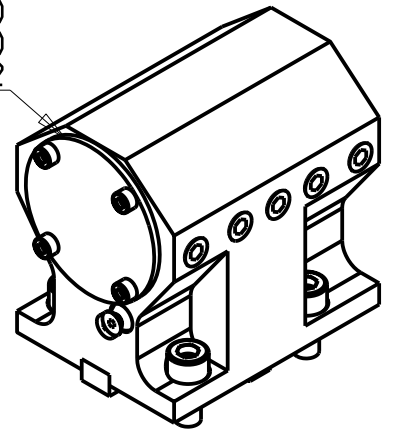

Cod. MT	Reversibile lato mandrino/contromandrino Reversible sub/main spindle side Umkehrbare Spindel-seite/ Gegenspindel-seite	Lubrificazione int. opzionale Coolant through optional Innenkuehlung Optional	Lubrificazione est. Ext. coolant Aussehenkuehlung	Misure Dimensions Masse	D
DW02355000	X	X	X	mm	50
DW02355080	X	X	X	Inch	2"

DOOSAN BMT 55

MOD: PUMA 230-240M/MS-280LM - PUMA 1500-2000-2500M/MS/Y/SY - LINX 300 M - PUMA 2100 12ST.
 PUMA 2600 16ST. - TL2000-2500 (M) - PUMA GT2100-2600 M - PUMA H250TM - PUMA QL200HM

PORTAUTENSILE ASSIALE PER BARENO Ø50mm / Ø2" H=75mm

Axial single boring bar holder Ø50mm / Ø2" H=75mm

Axial Bohrhälter Ø50mm / Ø2" H=75mm

M.T. srl

Via Casio Albini 480
 Tel. 0541/956034-957884
 Fax 0541/956341
 47842 S. GIOVANNI IN M. (RN)
 e-mail: mtma@mtmarchetti.com
 http://www.mtmarchetti.com

PRODUZIONE MODULI ROTANTI



PAGINA DW0610-2-10

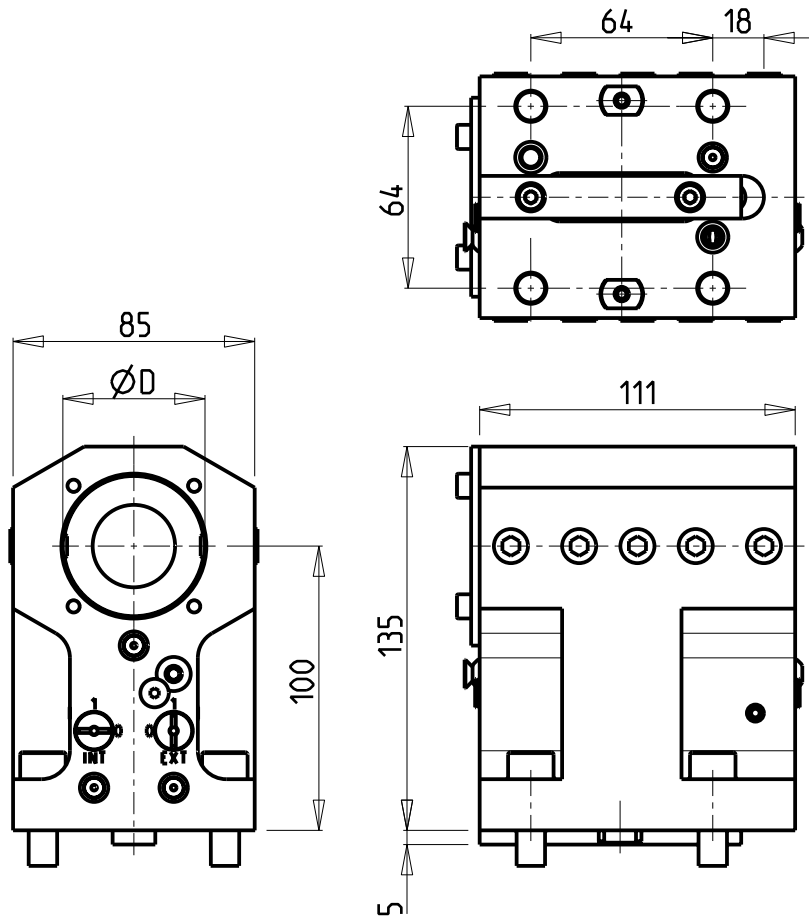

PER BOCCOLE DI RIDUZIONE VEDI PAG. TBL150-1-00
 FOR REDUCING BUSHINGS SEE PAGE TBL150-1-00
 FÜR REDUZIERBUCHSE SIEHE SEITE TBL150-1-00

KIT ADDUZIONE INTERNA (OPZIONALE)
 KIT FOR INTERNAL COOLANT (OPTIONAL)
 KIT FÜR INTERNE KÜHLMITTELZUFUHR (OPTIONAL)
 Ø50-Ø2" cod. KIT1000002

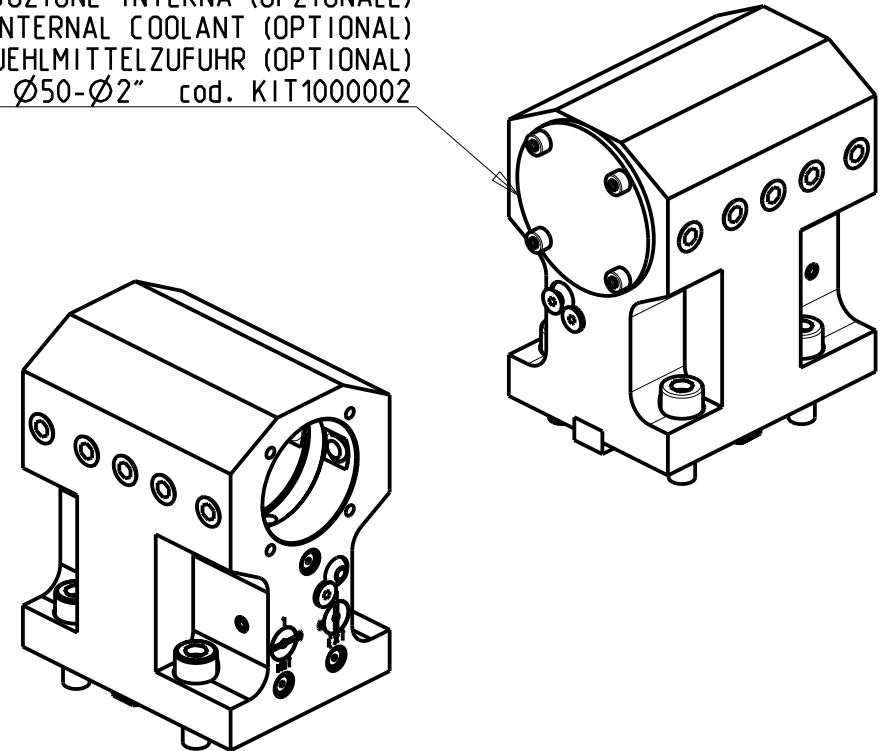

Cod. MT	N°Utensili N° Tools N° Werkzeuge	Reversibile lato mandrino/contromandrino Reversible sub/main spindle side Umkehrbare Spindel-seite/ Gegenspindel-seite	Lubrificazione int. opzionale Coolant through optional Innenkuehlung Optional	Lubrificazione est. Ext. coolant Aussenkuehlung	Misure Dimensions Masse	D
DW 0115000	1	X	X	X	mm	50
DW 0115080	1	X	X	X	Inch	2"

DOOSAN BMT 55

MOD: PUMA 230-240M/MS-280LM - PUMA 1500-2000-2500M/MS/Y/SY - PUMA 2100 12ST. - PUMA TT1500-TT1800MS/SY
 PUMA TL2000-2500 (M) - MX1600/2100ST 12ST.

PORTAUTENSILE ASSIALE PER BARENO Ø50mm / Ø2" H=100mm

Axial single boring bar holder Ø50mm / Ø2" H=100mm

Axial Bohrhälter Ø50mm / Ø2" H=100mm

Subject to change without notice.

M.T. srl

Via Casino Albini 480
 Tel. 0541/956034-957884
 Fax 0541/956341
 47842 S. GIOVANNI IN M. (RN)
 e-mail: mtma@mtmarchetti.com
 http://www.mtmarchetti.com

PRODUZIONE MODULI ROTANTI



PAGINA DW0620-2-10

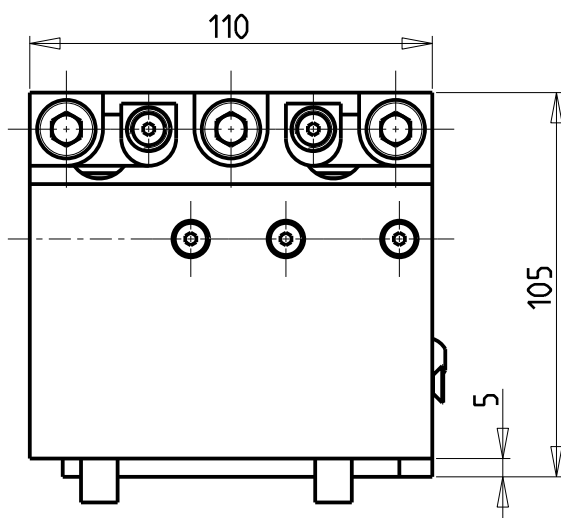
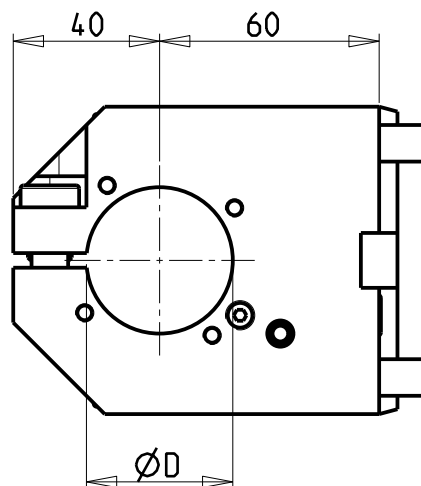
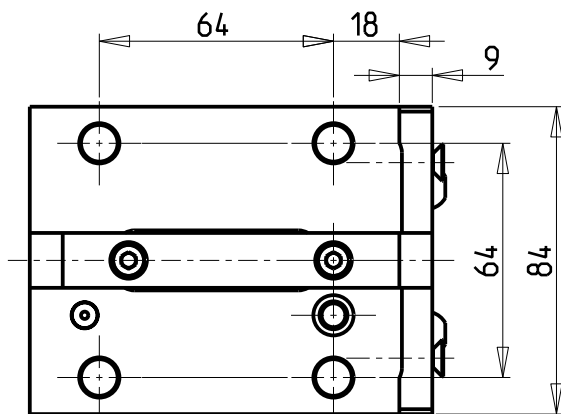

KIT ADDUZIONE INTERNA (OPZIONALE)
 KIT FOR INTERNAL COOLANT (OPTIONAL)
 KIT FUER INTERNE KUEHLMITTELZUFUHR (OPTIONAL)
 Ø40 cod. KIT1003003
 Ø1 1/2" cod. KIT1003004

SOLO GUARNIZIONE (OPZIONALE)
 ONLY SEAL (OPTIONAL)
 NUR DICHTUNG (OPTIONAL)
 cod. 0520013

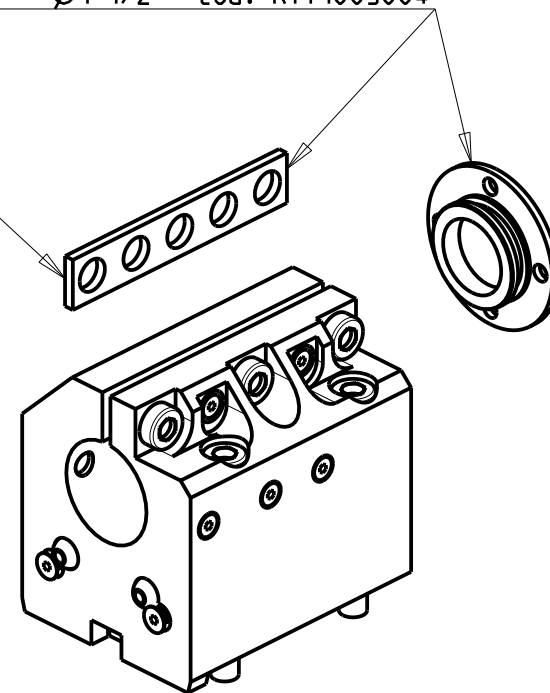

PER BOCCOLE DI RIDUZIONE VEDI PAG. TBL150-1-00
 FOR REDUCING BUSHINGS SEE PAGE TBL150-1-00
 FÜR REDUZIERBUCHSE SIEHE SEITE TBL150-1-00

Cod. MT	N°Utensili N°Tools N°Werkzeuge	Reversibile lato mandrino/controlmandrino Reversible sub/main spindle side Umkehrbare Spindel-seite/ Gegenspindel-seite	Lubrificazione int. opzionale Coolant through optional Innenkühlung Optional	Lubrificazione est. Ext. coolant Aussenkühlung	Misure Dimensions Masse	D
0814000	1	X	X	X	mm	40
0813810	1	X	X	X	Inch	1 1/2"

DOOSAN BMT 55

MOD: PUMA 230-240M/MS-280LM - PUMA 1500-2000-2500M/MS/Y/SY - LINX 300 M - PUMA 2100 12ST. - PUMA 2600 16ST.
 TL2000-2500 (M) - PUMA GT2100-2600 M

PORTAUTENSILE ASSIALE PER BARENO Ø40mm / Ø1 1/2" H=60mm

Axial single boring bar holder Ø40mm / Ø1 1/2" H=60mm

Axial Bohrhälter Ø40mm / Ø1 1/2" H=60mm

Subject to change without notice.

M.T. srl

Via Casino Albini 480
 Tel. 0541/956034-957884
 Fax 0541/956341
 47842 S. GIOVANNI IN M. (RN)
 e-mail: mtma@mtmarchetti.com
 http://www.mtmarchetti.com

PRODUZIONE MODULI ROTANTI



PAGINA DW0630-2-20

PER BOCCOLE DI RIDUZIONE VEDI PAG. TBL150-1-00
 FOR REDUCING BUSHINGS SEE PAGE TBL150-1-00
 FÜR REDUZIERBUCHSE SIEHE SEITE TBL150-1-00

KIT ADDUZIONE INTERNA (OPZIONALE)
 KIT FOR INTERNAL COOLANT (OPTIONAL)
 KIT FUER INTERNE KUEHLMITTELZUFUHR (OPTIONAL)
 Ø40 cod. KIT1000003
 Ø1 1/2" cod. KIT1000004

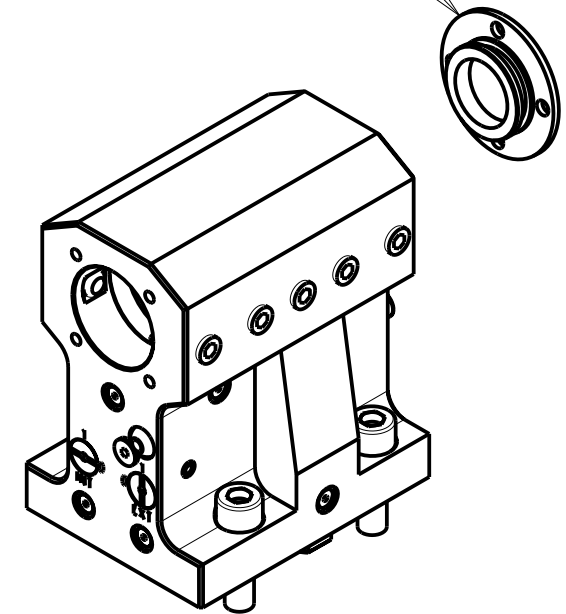
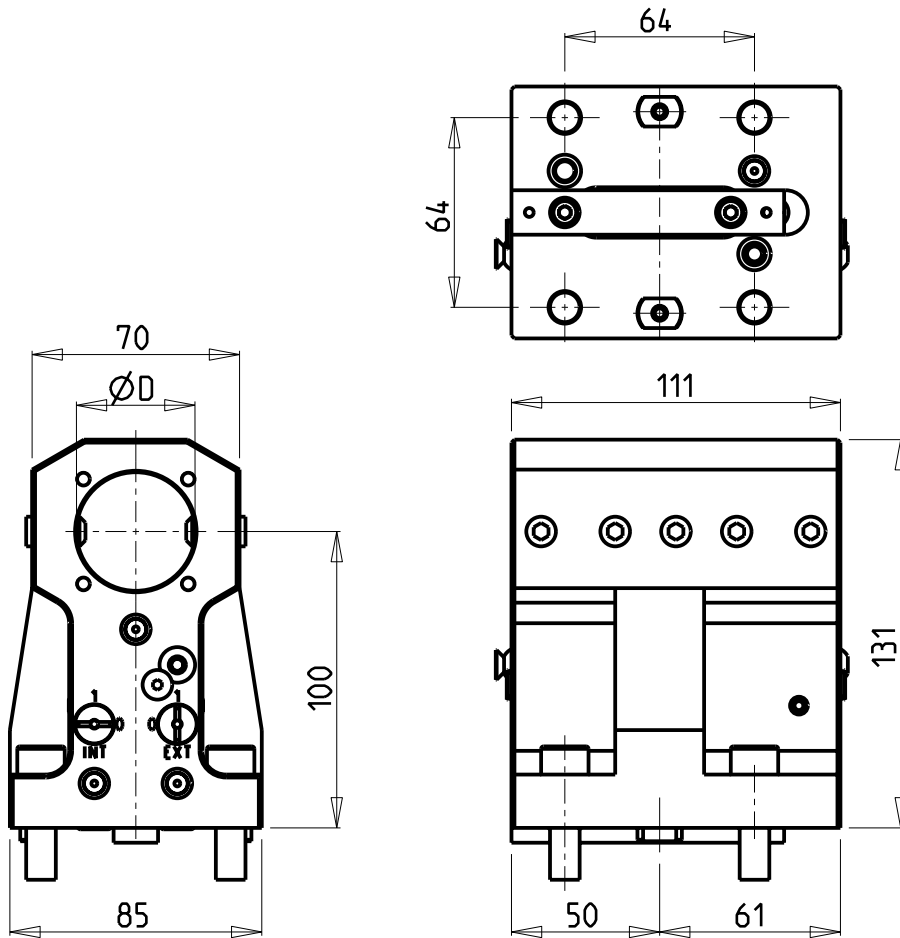

Cod. MT	N°Utensili N°Tools N°Werkzeuge	Reversibile lato mandrino/contromandrino Reversible sub/main spindle side Umkehrbare Spindel-seite/ Gegenspindel-seite	Lubrificazione int. opzionale Coolant through optional Innenkuehlung Optional	Lubrificazione est. Ext. coolant Aussenkuehlung	Misure Dimensions Masse	D
DW00394000	1	X	X	X	mm	40
DW00393810	1	X	X	X	Inch	1 1/2"

DOOSAN BMT 55

MOD: PUMA 230-240M/MS-280LM - PUMA 1500-2000-2500M/MS/Y/SY - PUMA 2100 12ST. - PUMA TT1500-1800-2100MS/SY/SYY
 PUMA TL2000-2500 (M) - MX1600/2100ST 12ST.

PORTAUTENSILE ASSIALE PER BARENO Ø40mm / Ø1 1/2" H=100mm

Axial single boring bar holder Ø40mm / Ø1 1/2" H=100mm

Axial Bohrhälter Ø40mm / Ø1 1/2" H=100mm

Subject to change without notice.

M.T. srl

Via Casino Albini 480
 Tel. 0541/956034-957884
 Fax 0541/956341
 47842 S. GIOVANNI IN M. (RN)
 e-mail: mtma@mtmarchetti.com
 http://www.mtmarchetti.com

PRODUZIONE MODULI ROTANTI



PAGINA DW0640-2-10

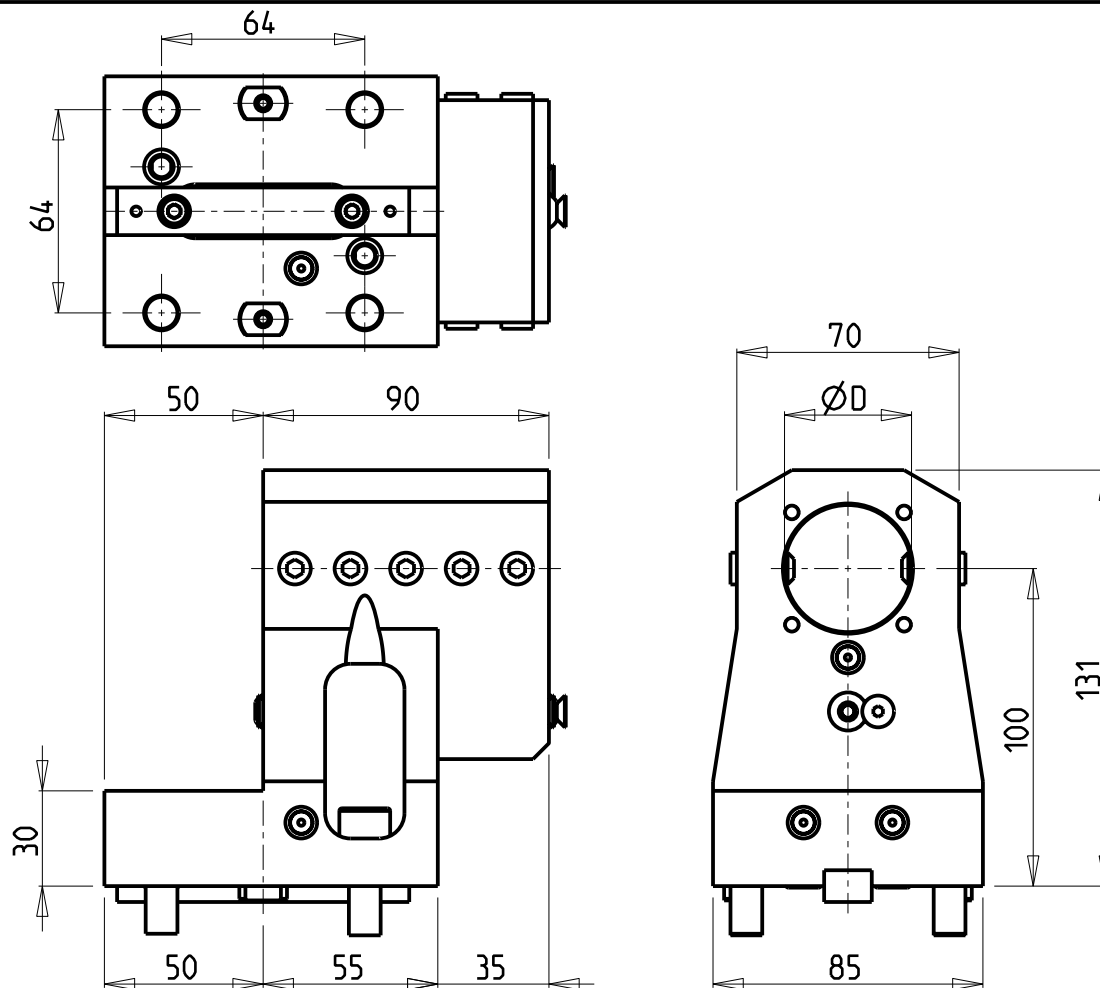

ATTENZIONE - ATTENTION - ACHTUNG

- VERIFICARE LE MISURE DI INGOMBRO PER POSSIBILE INTERFERENZA SU ALCUNI MODELLI DI MACCHINE
- Please check the overall sizes for possible interferences on some machine models
- Bitte überprüfen sie das ausmass um mögliche interferenzen auf einigen maschinen modellen zu vermeiden

KIT ADDUZIONE INTERNA (OPZIONALE)
 KIT FOR INTERNAL COOLANT (OPTIONAL)
 KIT FUER INTERNE KUEHLMITTELZUFUHR (OPTIONAL)
 Ø40 cod. KIT1000003

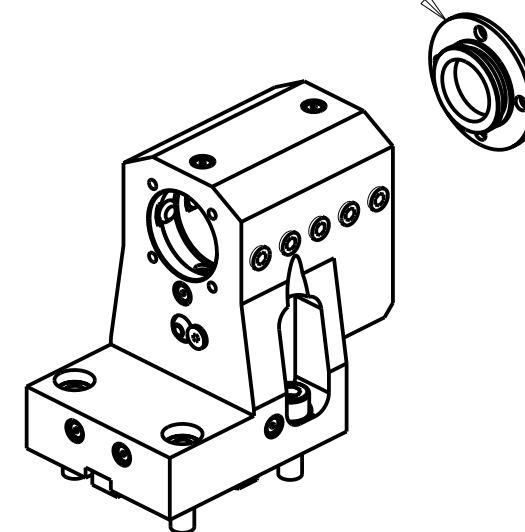

PER BOCCOLE DI RIDUZIONE VEDI PAG. TBL150-1-00
 FOR REDUCING BUSHINGS SEE PAGE TBL150-1-00
 FÜR REDUZIERBUCHSE SIEHE SEITE TBL150-1-00

Cod. MT	Reversibile lato mandrino/contromandrino Reversible sub/main spindle side Umkehrbare Spindel-seite/ Gegenspindel-seite	Lubrificazione int. opzionale Coolant through optional Innenkuehlung Optional	Lubrificazione est. Ext. coolant Aussenkuehlung	Misure Dimensions Masse	D
DW02344000	X	X	X	mm	40

DOOSAN BMT 55

MOD: PUMA 230-240M/MS-280LM - PUMA 1500-2000-2500M/MS/Y/SY - PUMA 2100 12ST. - PUMA TT1500-1800-2100MS/SY/SYY
 PUMA TL2000-2500 (M) - MX1600/2100ST 12ST.

PORTAUTENSILE ASSIALE ARRETRATO PER BARENO Ø40mm H=100mm

Axial rear set boring bar holder Ø40mm H=100mm

Axial Bohrhälter zurueckversetzt Ø40mm H=100mm

Subject to change without notice.

M.T. srl

Via Casino Albini 480
 Tel. 0541/956034-957884
 Fax 0541/956341
 47842 S. GIOVANNI IN M. (RN)
 e-mail: mtma@mtmarchetti.com
 http://www.mtmarchetti.com

PRODUZIONE MODULI ROTANTI



PAGINA DW0840-2-10

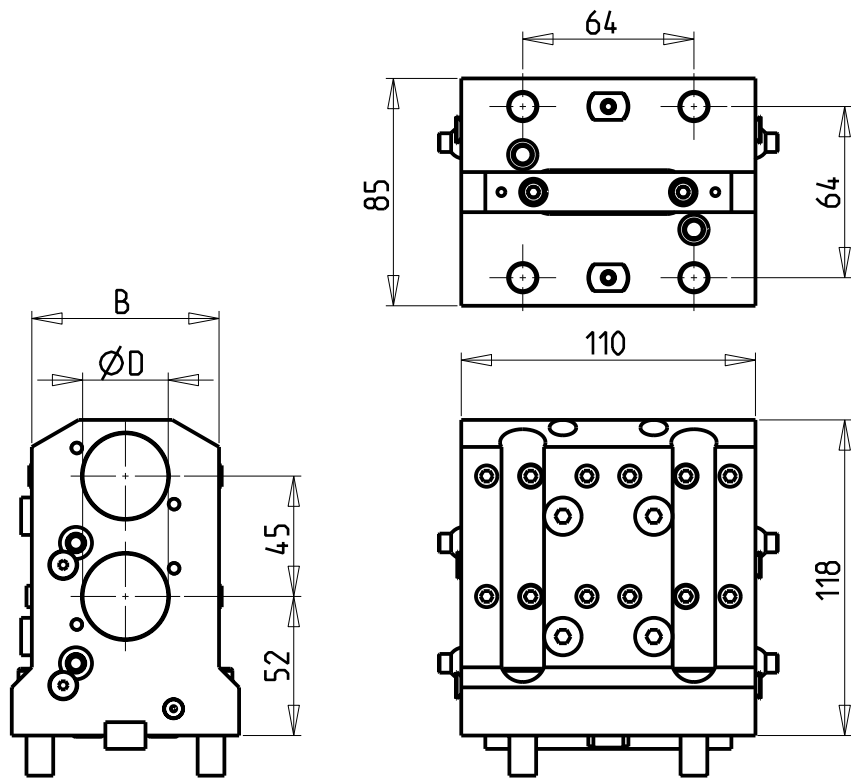

KIT ADDUZIONE INTERNA (OPZIONALE)
 KIT FOR INTERNAL COOLANT (OPTIONAL)
 KIT FUER INTERNE KUEHLMITTELZUFUHR (OPTIONAL)
 Ø20-3/4" cod. KIT1000005
 Ø25-1" cod. KIT1000006
 Ø32-1 1/4" cod. KIT1000001

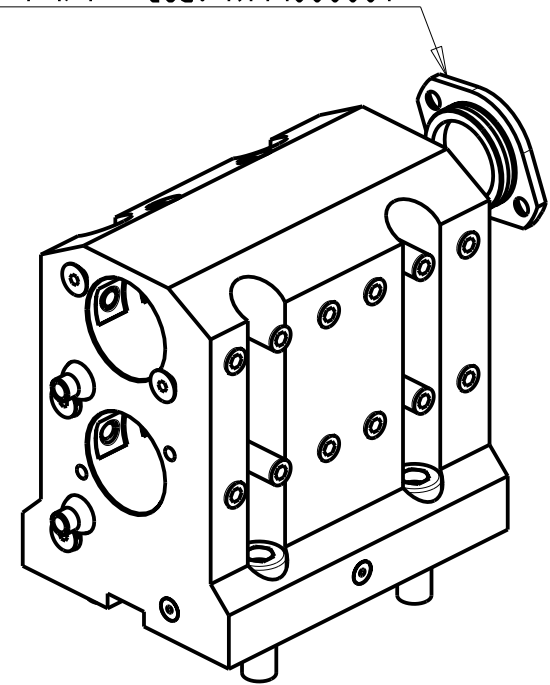

PER BOCCOLE DI RIDUZIONE VEDI PAG. TBL150-1-00
 FOR REDUCING BUSHINGS SEE PAGE TBL150-1-00
 FÜR REDUZIERBUCHSE SIEHE SEITE TBL150-1-00

Cod. MT	N°Utensili N°Tools N°Werkzeuge	Reversibile lato mandrino/contromandrino Reversible sub/main spindle side Umkehrbare Spindel-seite/ Gegenspindel-seite	Lubrificazione int. opzionale Coolant through optional Innenkuhlung Optional	Lubrificazione est. Ext. coolant Aussenkuhlung	Misure Dimensions Masse	D	B
DW 00092000	2	X	X	X	mm	20	62
DW 00091905	2	X	X	X	Inch	3/4"	62
DW 00092500	2	X	X	X	mm	25	70
DW 00092540	2	X	X	X	Inch	1"	70
DW 00093175	2	X	X	X	Inch	1 1/4"	70
DW 00093200	2	X	X	X	mm	32	70

DOOSAN BMT 55

MOD: PUMA 230-240M/MS-280LM - PUMA 1500-2000-2500M/MS/Y/SY - LINX 300 M - PUMA 2100 12ST. - PUMA 2600 16ST.
 TL2000-2500 (M)

PORTAUTENSILE ASSIALE PER BARENO 2 POSIZIONI Ø20mm / Ø3/4" / Ø25mm / Ø1" / Ø1 1/4" / Ø32mm
 Axial double boring bar holder Ø20mm / Ø3/4" / Ø25mm / Ø1" / Ø1 1/4" / Ø32mm
 Axial Bohrhälter 2 Positionen Ø20mm / Ø3/4" / Ø25mm / Ø1" / Ø1 1/4" / Ø32mm

Subject to change without notice.

M.T. srl

Via Casino Albini 480
 Tel. 0541/956034-957884
 Fax 0541/956341
 47842 S. GIOVANNI IN M. (RN)
 e-mail: mtma@mtmarchetti.com
 http://www.mtmarchetti.com

PRODUZIONE MODULI ROTANTI



PAGINA DW 0862-2-00

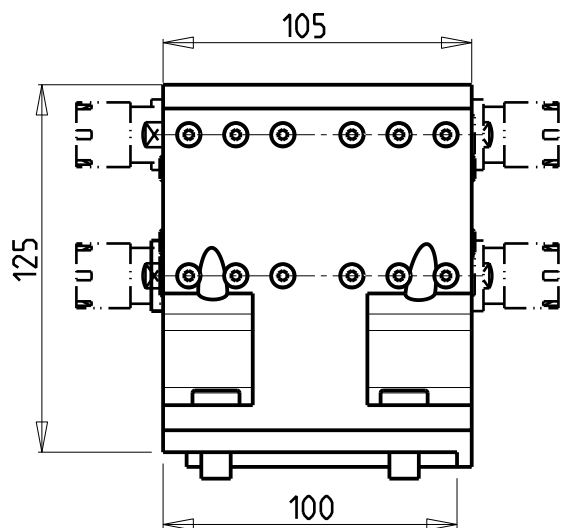
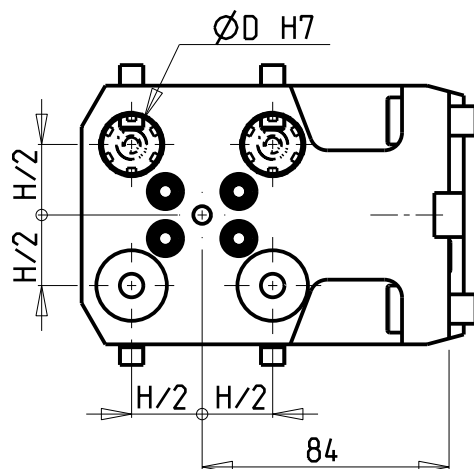
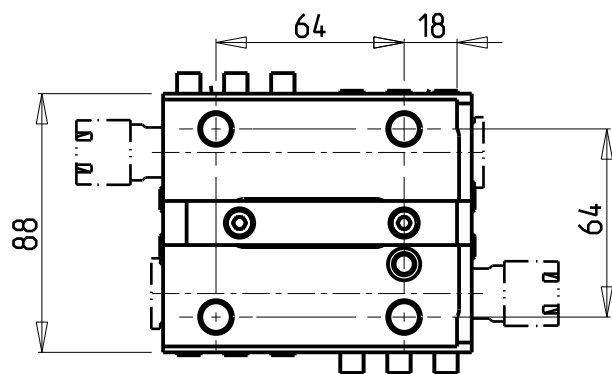

DOTAZIONI - SUPPLIED WITH - AUSSTATTUNG

mm	N*5 Boccole - Bushings - Buchsen Ø16-12-10-8-6 N*1 ER16 Portapinza - Collet holder - Zangenhalter N*1 ER25 Portapinza - Collet holder - Zangenhalter
inch	N*3 Boccole - Bushings - Buchsen Ø1/2"-3/8"-1/4" N*1 ER16 Portapinza - Collet holder - Zangenhalter N*1 ER25 Portapinza - Collet holder - Zangenhalter

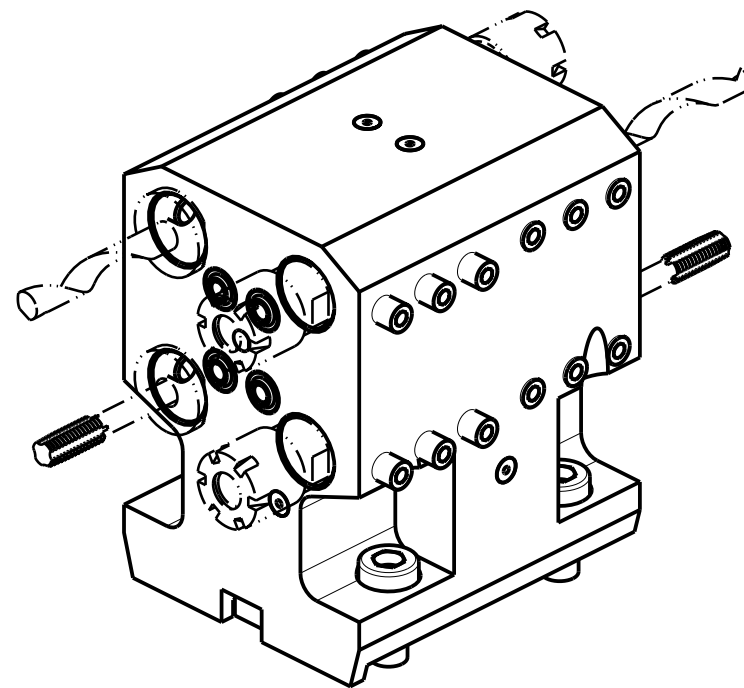

Cod. MT	N°Utensili N°Tools N°Werkzeuge	Lubrificazione est. Ext. coolant Aussenkuehlung	Reversibile lato mandrino/contromandrino Reversible sub/main spindle side Umkehrbare Spindelseite/ Gegenspindelseite	Misure Dimensions Masse	D	H
0782000	4+4	X	X	mm	20	48
0781905	4+4	X	X	Inch	3/4"	1 7/8"

DOOSAN BMT 55

MOD: PUMA 1500-2000-2500M/MS/Y/SY - PUMA 2100 12ST. - TL2000-2500 (M)

PORTAUTENSILE ASSIALE PER BARENO 4+4 POSIZIONI Ø20mm / Ø3/4"

Axial 4+4 position boring bar holder Ø20mm / Ø3/4"

Axial Bohrhalter 4+4 Positionen Ø20mm / Ø3/4"

Subject to change without notice.

M.T. srl

Via Casino Albini 480
Tel. 0541/956034-957884
Fax 0541/956341
47842 S. GIOVANNI IN M. (RN)
e-mail: mtma@mtmarchetti.com
http://www.mtmarchetti.com

PRODUZIONE MODULI ROTANTI



PAGINA DW 0924-2-00

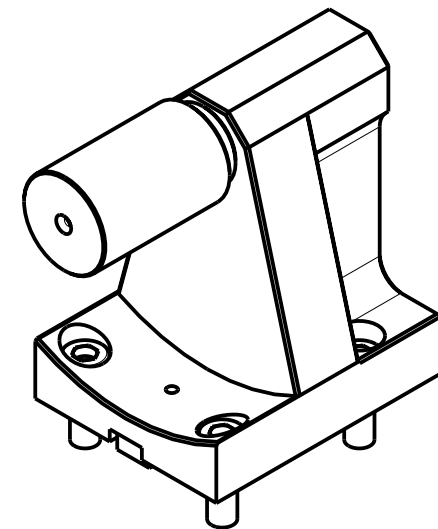
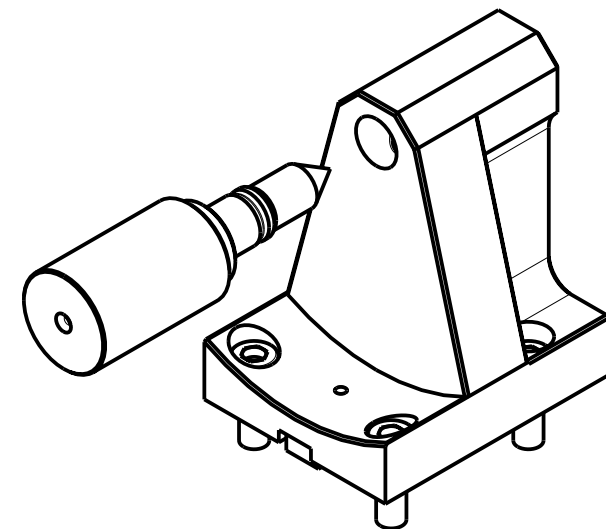
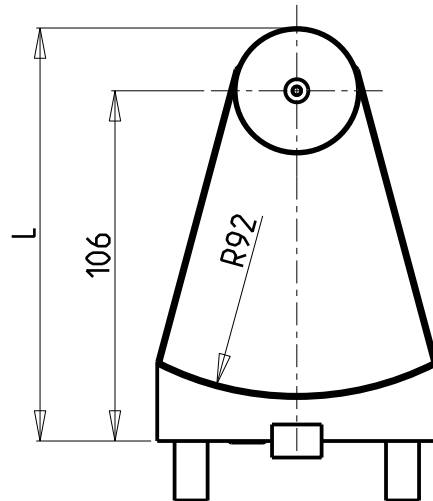
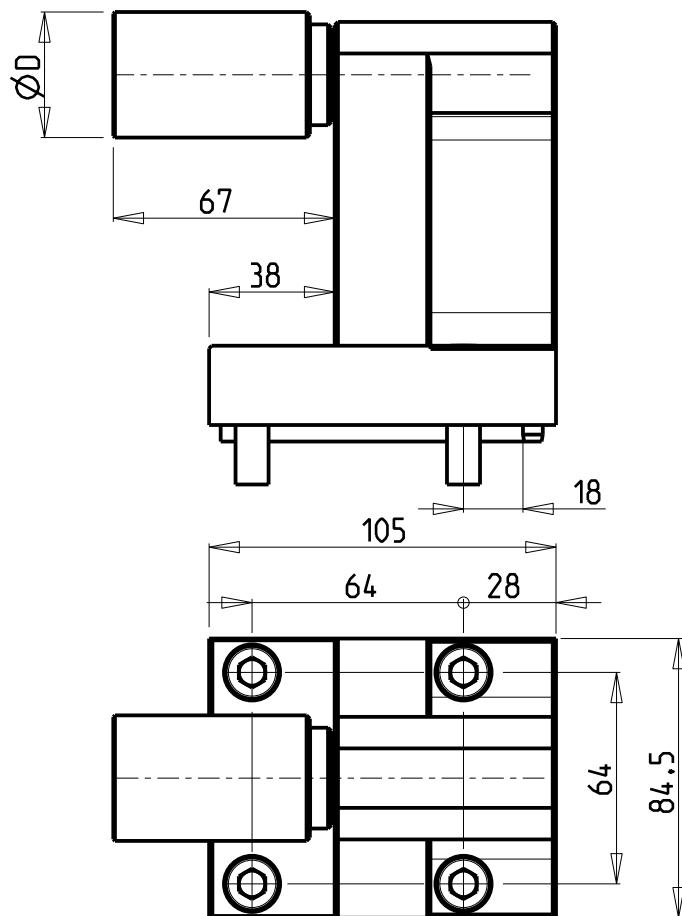

ATTENZIONE - ATTENTION - ACHTUNG

- cod. 0820100L : FUORI VOLTEGGIO!
- cod. 0820100L : OUT OF MAXIMUM SWING!
- cod. 0820100L : WERKZEUG AUSSER INTERFERENZ!

Cod. MT	N°Utensili N° Tools N° Werkzeuge	D	L
0820100	1	38	125
0820100L	1	2"	131.4

DOOSAN BMT 55

MOD: PUMA 230-240M/MS-280LM - PUMA 1500-2000-2500M/MS/Y/SY - LINX 300 M - PUMA 2100 12ST.
PUMA TT1500-1800-2100MS/SY/SYY - PUMA TL2000-2500 (M) - MX1600/2100ST 12ST.

CONTROPUNTA PER CONTROMANDRINO

Tailstock for subspindle

Gegenspitz fuer Gegenspindel

Subject to change without notice.

M.T. srl

Via Casino Albini 480
Tel. 0541/956034-957884
Fax 0541/956341
47842 S. GIOVANNI IN M. (RN)
e-mail: mtma@mtmarchetti.com
http://www.mtmarchetti.com

PRODUZIONE MODULI ROTANTI



PAGINA DW0950-2-00

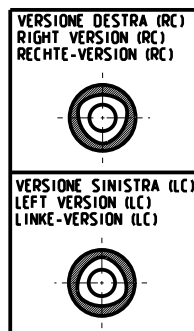
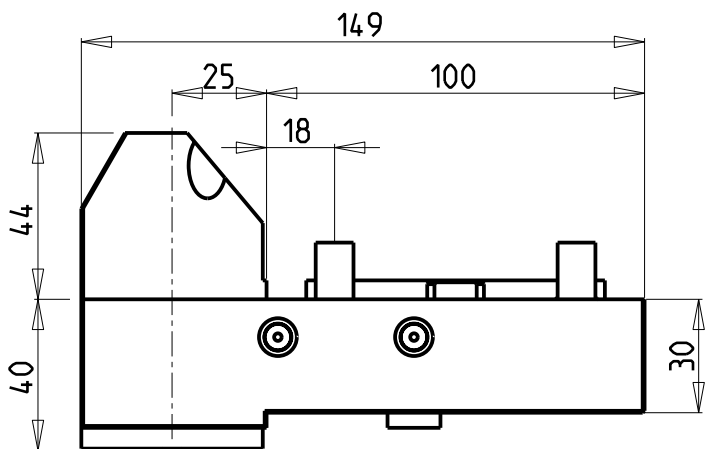
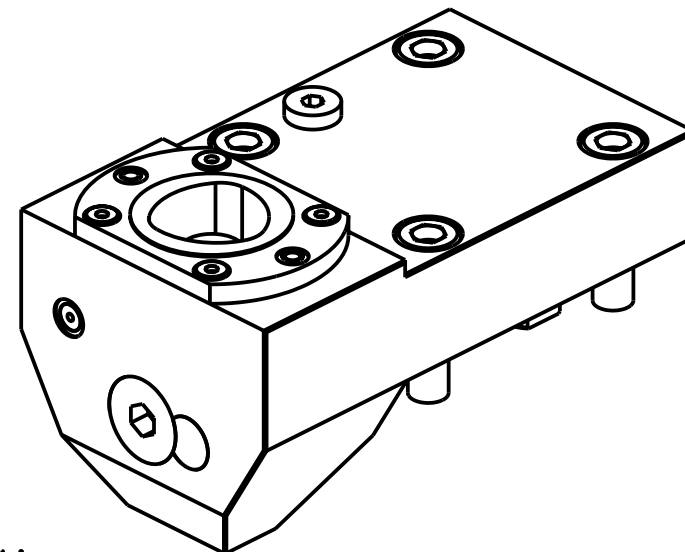
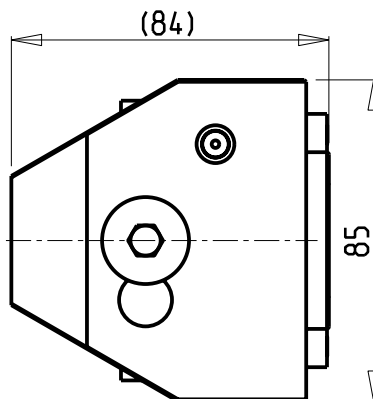
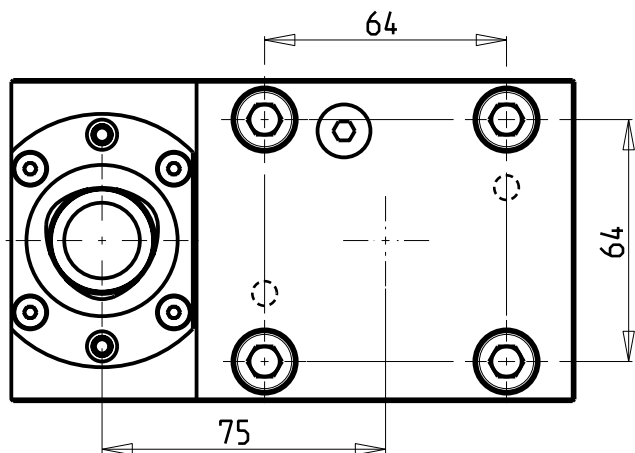

PER ORDINARE LA VERSIONE SX
AGGIUNGERE "LC" AL CODICE IN TABELLA.
ES: DW00444010 DIVENTA DW00444010LC

TO ORDER LEFT VERSION
ADD A "LC" IN THE CODE-CHARTS.
EXAMPLE: DW00444010 BECOMES DW00444010LC

UM DIE LINKE-VERSION ZU BESTELLEN, BEI DER
ARTIKELBEZEICHNUNG "LC" HINZUFUEGEN.
BEISPIEL: DW00444010 WIRD DANN DW00444010LC

Cod. MT	N°Utensili N°Tools N°Werkzeuge	Lubrificazione int. Coolant through Innenkuehlung	Lubrificazione est. Ext. coolant Aussenkuehlung	Reversibile lato mandrino/contromandrino Reversible sub/main spindle side Umkehrbare Spindelsete/ Gegenspindelsete	TAGLIA Size Masse
DW00444010	1	X	X	X	C4

DOOSAN BMT 55

MOD: PUMA 230-240M/MS-280LM - PUMA 1500-2000-2500M/MS/Y/SY - PUMA 2100 12ST. - PUMA 2600 16ST. - PUMA H250TM
PUMA TT1500-1800-2100MS/SY/SYY - PUMA TL2000-2500 (M) - MX1600/2100ST 12ST. - PUMA GT2100-2600 M - PUMA QL200HM

PORTAUTENSILE RADIALE SINGOLO ARRETRATO MT CAPTO

Single rear-set radial static tool MT CAPTO

Radial Single-Werkzeughalter zurueckversetzt MT CAPTO

Subject to change without notice.

M.T. srl

Via Casino Albini 480
Tel. 0541/956034-957884
Fax 0541/956341
47842 S. GIOVANNI IN M. (RN)
e-mail: mtma@mtmarchetti.com
http://www.mtmarchetti.com

PRODUZIONE MODULI ROTANTI



PAGINA DW0430-B-40

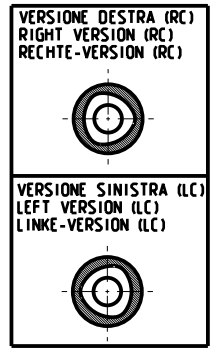
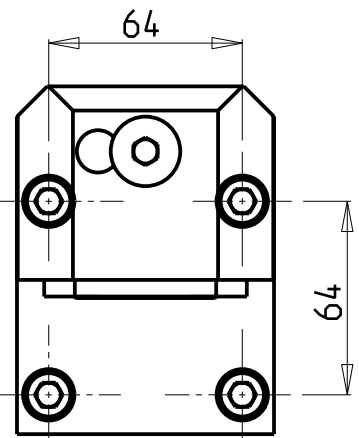
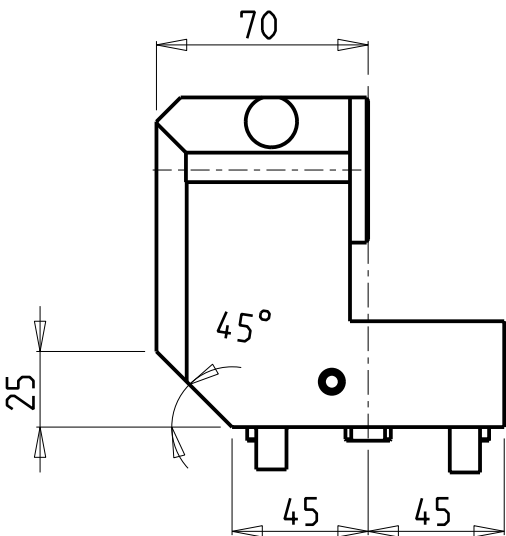
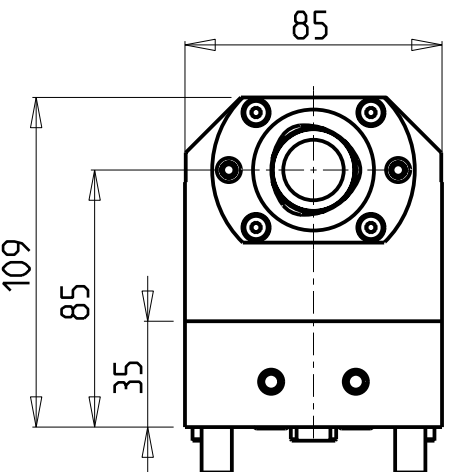

PER ORDINARE LA VERSIONE SX
 AGGIUNGERE "LC" AL CODICE IN TABELLA.
 ES: DW02434010 DIVENTA DW02434010LC

TO ORDER LEFT VERSION
 ADD A "LC" IN THE CODE-CHARTS.
 EXAMPLE: DW02434010 BECOMES DW02434010LC

UM DIE LINKE-VERSION ZU BESTELLEN, BEI DER
 ARTIKELBEZEICHNUNG "LC" HINZUFUEGEN.
 BEISPIEL: DW02434010 WIRD DANN DW02434010LC

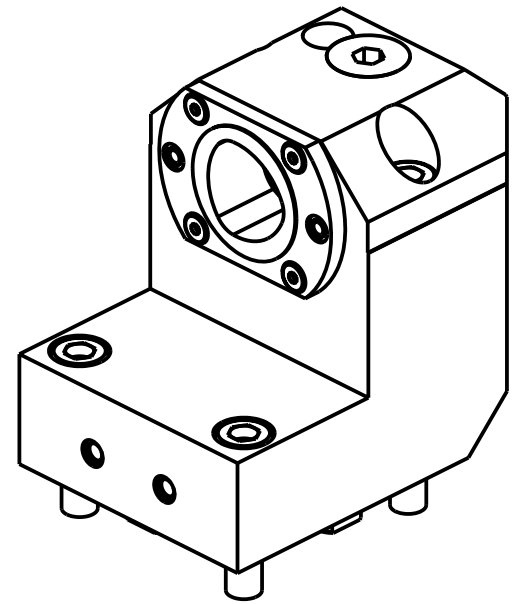

Cod. MT	Lubrificazione int. Coolant through Innenkuehlung	Reversibile lato mandrino/contromandrino Reversible sub/main spindle side Umkehrbare Spindelseite/ Gegenspindelseite	TAGLIA Size Masse
DW02434010	X	X	C4

DOOSAN BMT 55
 MOD: PUMA 230-240M/MS-280LM - PUMA 1500-2000-2500M/MS/Y/SY - LINX 300 M - PUMA 2100 12ST. - PUMA H250TM
 PUMA TT1500-1800-2100MS/SY/SYY - PUMA TL2000-2500 (M) - MX1600/2100ST 12ST. - PUMA QL200HM

PORTAUTENSILE ASSIALE SINGOLO ARRETRATO MT CAPTO
 Axial rear-set boring single static tool MT CAPTO
 Axial Single-Werkzeughalter zurueckversetzt MT CAPTO

Subject to change without notice.

M.T. srl
 Via Casino Albini 480
 Tel. 0541/956034-957884
 Fax 0541/956341
 47842 S. GIOVANNI IN M. (RN)
 e-mail: mtma@mtmarchetti.com
 http://www.mtmarchetti.com

PRODUZIONE MODULI ROTANTI



PAGINA DW0555-B-40